

# Series 19 SMART On/Off Electric Actuator User Manual

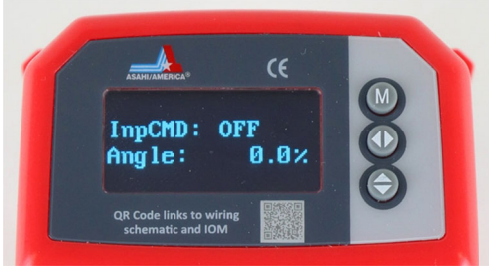

## Description

The Series 19 smart on/off electric actuator features a reversing motor with multi-voltage capabilities, 95 VAC to 265 VAC (50/60 Hz) or 24 VAC/VDC, an OLED screen, an internal heater, auxiliary contacts, alarm/fault contacts, a NEMA Type 4X enclosure, manual override, visual beacon position indication, LED indicator (open/close/alarm), ISO mounting, and flying leads. The auxiliary contacts and alarm/fault contacts are SPST and rated for 0.1 Amp @ 250 VAC/0.5 Amp @ 30 VDC, and are factory calibrated.

**Cover removal is NOT required for installation and will void warranty!!**

***Additional options are NOT available for this model.***

## Electrical Requirement

**WARNING: Do not open actuator cover as warranty will be void!!**

Model Number	Torque (in/lbs)	95 VAC to 265 VAC		24 VAC/24 VDC		Cycle Time per 90 Degrees (Seconds)	Weight (Pounds)
		Amp Draw	Duty Cycle	Amp Draw	Duty Cycle		
S20HM2W	177	0.18	75%	0.96	75%	10 seconds	1.7
S50HM2W	442	0.24	75%	1.2	75%	10 seconds	3.5
S110HM2W	973	0.84	75%	4.8	75%	10 seconds	4.8

NOTE: Amp rating is considered running.

Duty cycles are for ambient temperature (73° F)

The Series 19 electric actuator has a sealed cable gland with 2 meter flying leads. The electrician is required to make field connections as per the wiring schematic shown in this manual for model numbers and voltages listed above. The electrician is responsible for following all and any, local and/or agency wiring practices.

**Note: Not all wires provided will be used.**

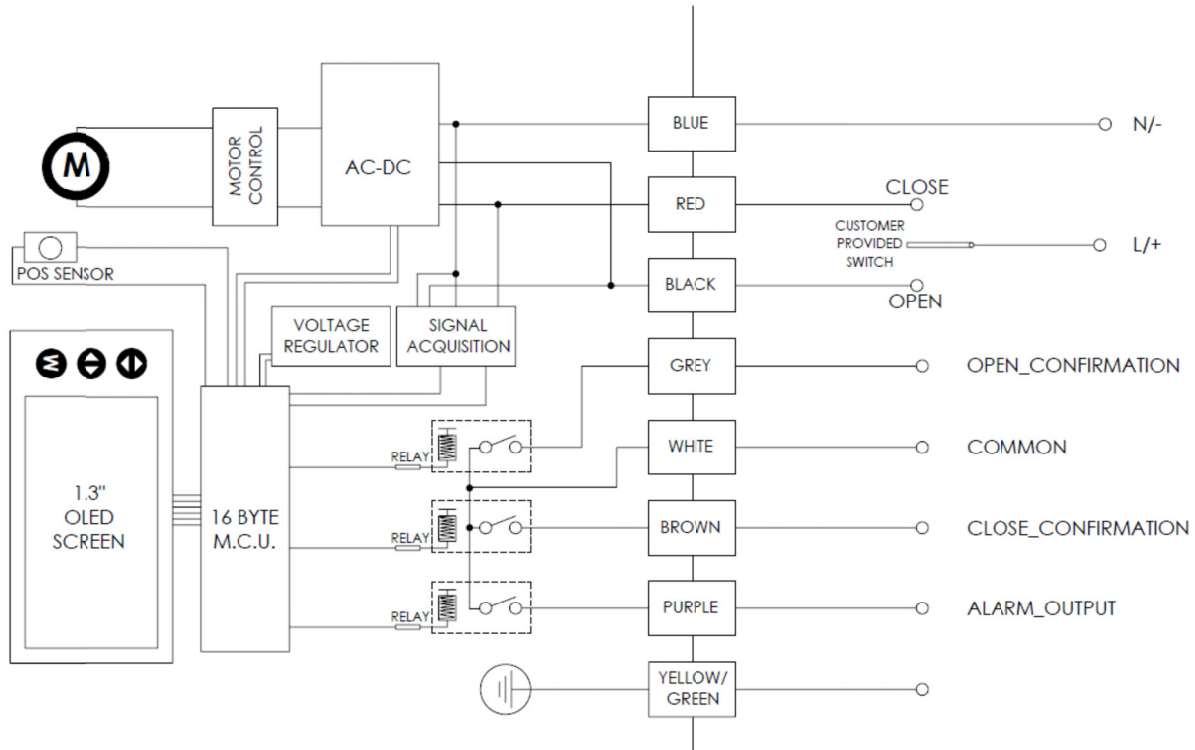

- Blue is negative/neutral
- Black is hot to open
- Red is hot to close
- White is common for confirmation and alarm
- Grey is relay contact for open confirmation
- Brown is relay contact for close confirmation
- Purple is relay contact for alarm

Heater is internally wired and operational as long as actuator is powered.

LED visual indicator is green for open, red for closed, or blue for alarm condition. Alarm condition could be a motor fault, valve jam, etc.

### **Manual Override Operation**

Remove manual override hex key from storage position located on the bottom of actuator, which is secured by stainless steel clips. To operate the manual override, insert hex key into hex socket located on top of actuator and rotate to manually cycle valve (CCW to open, CW to close). When finished using the manual override, it is imperative to remove the hex key and place it back into storage on actuator base, making sure that it “clicks” into the locking position.

**CAUTION:** The manual override should only be used when there is no power applied to actuator. When power is restored the actuator will automatically resume normal operation.

## Local Controls Operation

The actuator can be locally controlled and driven to the open or closed position via OLED screen and push buttons. This simple procedure is detailed below.

Press and hold the “↓” button for 3 seconds. “K3” will flash in the top right hand corner and the unit will ask for a password. At this time, the password of “111” can be entered with “↓” selecting numbers and “←” selecting the field. Once password is entered, press the “M” button to enter manual mode. The actuator can now be opened and closed via the push buttons. Press the “↓” button to OPEN the actuator. Press the “←” button to CLOSE the actuator. To exit manual mode, press the M button or wait approximately 120 seconds and the manual mode will time out and exit. The actuator will not respond to control signals from the PLC until taken out of manual mode.

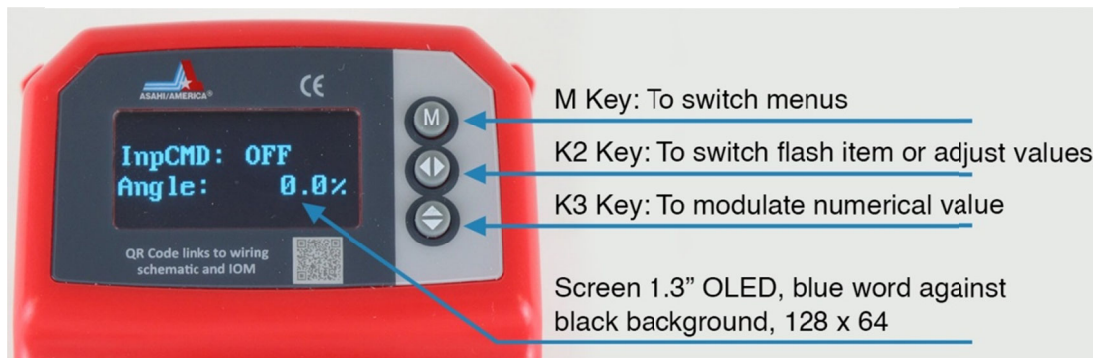

## Troubleshooting

Actuator does not respond

Power not connected	Connect power
Voltage below level or incorrect	Confirm correct voltage
Torque limiter tripped	Power unit in opposite direction, then power to original position to confirm a tripped torque limiter
Loose/poor termination	Confirm proper termination

## Series 19 ISO 5211 Output

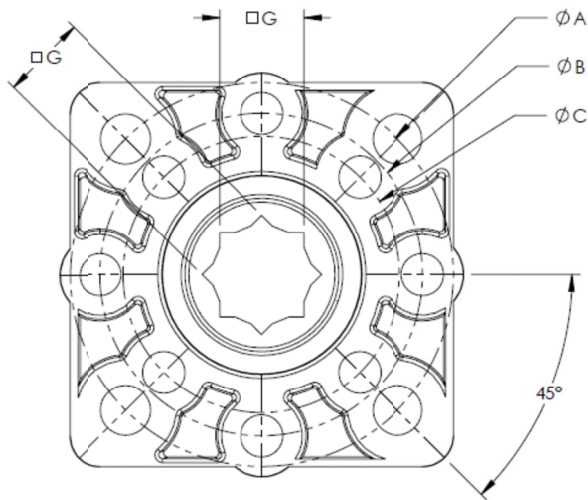

ACTUATOR SIZE	ØA	ØB	ØC	□G
S20	F05 (M6)	F04 (M5)	F03 (M5)	14MM
S50	F07 (M8)	F05 (M6)	N/A	14MM
S110	F07 (M8)	F05 (M6)	N/A	17MM

## Series 19 Envelope Dimensions

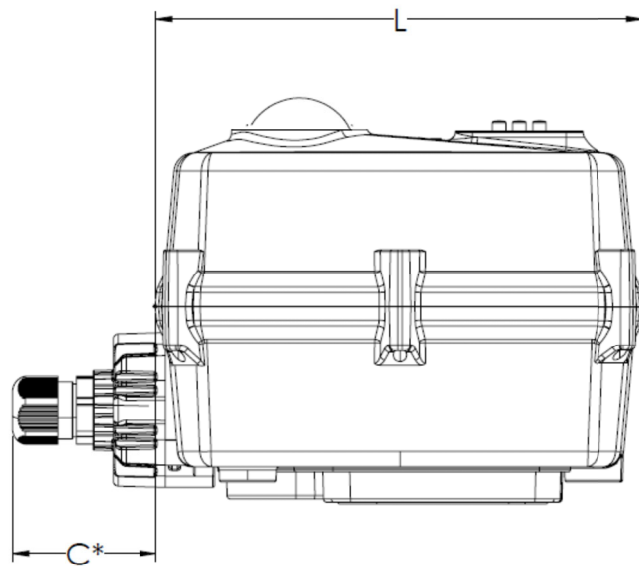
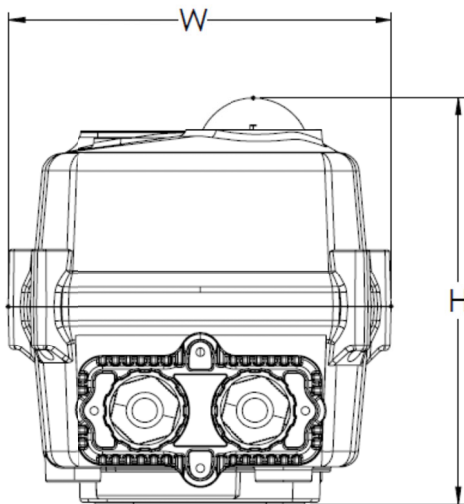

	L	W	H	C
S20	4.01"	2.76"	3.54"	N/A
S50	5.13"	4.33"	4.72"	N/A
S110	5.75"	4.53"	4.80"	1.69"

\*DIMENSION C IS ONLY FOR S110