

# Acrobat™ 355-630mm

Models: 2480101, 2480102, 2480103, 2480104



**Asahi/America, Inc.**

**ProWeld® Equipment**



Powered by



# Operator's Manual



Manual: 2479901  
Rev B 08/19  
Original Language: English

**Copyright 2018 McElroy Manufacturing, Inc.  
All rights reserved.  
P.O. Box 580550  
Tulsa, Oklahoma 74158-0550, USA**

# Important Safety Information

Most accidents that involve product operation, maintenance and repair are caused by failure to observe basic safety rules or precautions. An accident can often be avoided by recognizing potentially hazardous situations before an accident occurs. A person must be alert to potential hazards. This person should also have necessary training, skills and tools to perform these functions properly.

Advanced training is offered through McElroy University. Course offerings are meant to enhance your efficiency, productivity and safety in the proper use of McElroy equipment.

**Improper operation, maintenance or repair of this product can be dangerous and could result in injury or death.**

**Do not operate this product until you have carefully read, and understand all the sections of this manual, and all other equipment manuals that will be used with it.**

Follow all applicable federal, state, local, and industry specific regulations.

The hazards are identified by the "Safety Alert Symbol" and followed by a "Signal Word" such as "DANGER", "WARNING" or "CAUTION". The Safety Alerts are shown below.

The meaning of these safety alert symbols are as follows:

 **DANGER** - Indicates an imminently hazardous situation which, if not avoided, will result in death or serious injury.

 **WARNING** - Indicates a potentially hazardous situation which, if not avoided, could result in death or serious injury.

 **CAUTION** - Indicates a hazardous situation which, if not avoided, may result in minor or moderate injury.

Signal words "NOTICE" and "IMPORTANT" are used to bring attention to important information.

The meaning of these signal words are as follows:

**"NOTICE"** - Can keep you from doing something that might damage the machine or someone's property. It may also be used to alert against unsafe practices.

**"IMPORTANT"** - Can help you do a better job or make your job easier in some way.

**McElroy cannot anticipate every possible circumstance that might involve a potential hazard. The warnings in this publication and on the product are, therefore, not all inclusive. If a tool, procedure, work method or operating technique that is not specifically recommended by McElroy is used, you must satisfy yourself that it is safe for you and for others. You should also ensure that the product will not be damaged or be made unsafe by the operation, maintenance or repair procedures that you choose.**

The information, specifications, and illustrations in the publication are on the basis of information that was available at the time that the publication was written. The specifications, pressures, measurements, adjustments, illustrations, and other items can change at any time. These changes can affect the service that is given to the product. Obtain the complete and most current information before you start any job. The most current information is available at our website

**[www.mcelroy.com](http://www.mcelroy.com)**.

TX05337-04-18

## **WARNING**

When replacement parts are required for this product McElroy recommends using McElroy replacement parts or parts with equivalent specifications including, but not limited to, physical dimensions, type, strength and material.

**Failure to heed this warning can lead to premature failures, product damage, personal injury or death.**

# TABLE OF CONTENTS

## FOREWORD

---

Literature Information .....	1 - 1
Safety .....	1 - 1
Operation .....	1 - 1
Maintenance .....	1 - 1
Patent Information .....	1 - 2
Replacement Literature .....	1 - 2
Nameplate Locations .....	1 - 2
Replacement Parts .....	1 - 2
Limited Warranty .....	1 - 3

## SAFETY

---

General Safety .....	2 - 1
Safety Equipment .....	2 - 1
Heater Is Not Explosion Proof .....	2 - 2
Electric Motors are Not Explosion Proof .....	2 - 2
Overhead Loads .....	2 - 2
Electrical Safety .....	2 - 2
Units With Hydraulics .....	2 - 3
Crush Points .....	2 - 3
Carriage Handling .....	2 - 3
Facer Blades Are Sharp .....	2 - 3
Lifting Safety .....	2 - 4
Personal Lifting Safety .....	2 - 4
Heater is Hot .....	2 - 4
Sound Information .....	2 - 4
Fusion Procedures .....	2 - 4
Do Not Modify Machine .....	2 - 4

## GENERAL INFORMATION

---

Theory of Butt Fusion .....	3 - 1
Nomenclature .....	3 - 2
Unpack Acrobat™ Packages .....	3 - 7
Unpack Heater/Jaw Package: .....	3 - 8
Install Jaw Cylinder Clamps .....	3 - 9
Assemble QuikFit™ Carriage .....	3 - 10
Assemble Facer Drive Unit .....	3 - 14
Lift Equipment .....	3 - 15

## OPERATION - BUTT FUSION

---

Check Fluid Level .....	4 - 1
Connecting to Power .....	4 - 1
Connect HPU to QuikFit™ Carriage .....	4 - 3
Prepare Facer .....	4 - 3

Hydraulic Pressure .....	4 - 4
Support Pipe .....	4 - 4
Loading Pipe .....	4 - 4
Clamp the Pipe .....	4 - 5
Facing the Pipe.....	4 - 5
Check Alignment .....	4 - 6
Determine Drag Pressure.....	4 - 6
Calculate Fusion Pressure .....	4 - 7
Insert Heater .....	4 - 7
Heating the Pipe.....	4 - 8
Fusing the Pipe .....	4 - 8
Opening Jaws .....	4 - 9
Position Pipe for Next Joint .....	4 - 9

## **OPERATION - VERTICAL FUSION**

### **MOVABLE PIPE BELOW**

---

Vertical Fusion .....	5 - 1
Support Pipe .....	5 - 1
Check Fluid Level .....	5 - 1
Connecting to Power .....	5 - 2
Prepare Heater.....	5 - 2
Hydraulic Power Unit (HPU) .....	5 - 3
Connect HPU to QuikFit™ Carriage .....	5 - 4
Prepare Facer.....	5 - 4
Hydraulic Pressure .....	5 - 5
Facing the Pipe.....	5 - 6
Check Alignment .....	5 - 7
Set Hydraulic Pressures .....	5 - 7
Insert Heater .....	5 - 8
Heating the Pipe.....	5 - 8
Fusing the Pipe .....	5 - 9
Opening Jaws .....	5 - 10

## **OPERATION - VERTICAL FUSION**

### **MOVABLE PIPE ABOVE**

---

Vertical Fusion .....	6 - 1
Support Pipe .....	6 - 1
Check Fluid Level .....	6 - 1
Connecting to Power .....	6 - 2
Connect HPU to QuikFit™ Carriage .....	6 - 4
Prepare Facer.....	6 - 4
Hydraulic Pressure .....	6 - 5
Facing the Pipe.....	6 - 6
Check Alignment .....	6 - 7

Set Hydraulic Pressures .....	6 - 7
Insert Heater .....	6 - 8
Heating the Pipe (Positive Vertical Fusion Pressure) .....	6 - 8
Fusing the Pipe (Positive Vertical Fusion Pressure) .....	6 - 9
Heating the Pipe (Negative Vertical Fusion Pressure) .....	6 - 10
Fusing the Pipe (Negative Vertical Fusion Pressure) .....	6 - 10
Opening Jaws .....	6 - 11

## **STORAGE/TRANSPORT**

---

Pack Acrobat™ Packages.....	7 - 1
Pack Heater/Jaw Package:.....	7 - 2

## **MAINTENANCE**

---

Preventative Maintenance.....	8 - 1
Clean Machine.....	8 - 1
Check Machine Operation .....	8 - 1
Fasteners Are Tight .....	8 - 1
Clean Eyebolt and Thrust Bearing.....	8 - 2
Changing Heater Plates/Adapters .....	8 - 2
Facer Blades .....	8 - 2
Change Hydraulic Fluid and Filter .....	8 - 3
Change Facer Gear Oil .....	8 - 4
Bleeding Air From Hydraulic System.....	8 - 4
Bleeding Air From HPU.....	8 - 5

## **HYDRAULIC FLUIDS**

---

Hydraulic Fluids .....	9 - 1
------------------------	-------

## **SPECIFICATIONS**

---

Specifications .....	10 - 1
----------------------	--------

## **NOTES**

---

Notes.....	11 - 1
------------	--------

## **GENERATOR SIZING FORM**

---

Generator Sizing Form .....	12 - 1
-----------------------------	--------

# FOREWORD

---

## Literature Information

This manual should be stored in a protected location for future reference. Use the literature holder if provided with the product.

This manual contains safety information, operation instructions, transportation information, lubrication information and maintenance information.

Some photographs or illustrations in this publication show details or equipment that can be different from your machine. Guards and covers might have been removed for illustrative purposes.

Continuing improvement and advancement of product design might have caused changes to your machine which are not included in this publication. Read, study and keep this manual with the machine.

Whenever a question arises regarding your machine, or this publication, please contact Asahi/America Technical Services at 1-800-343-3618 or [pipe@asahi-america.com](mailto:pipe@asahi-america.com).

## Safety

The safety section lists basic safety precautions. In addition, this section identifies the text and locations of warning signs and labels used on the machine.

Read and understand the basic precautions listed in the safety section before operating or performing maintenance and repair on this machine.

## Operation

The operation section is a reference for the new operator and a refresher for the experienced operator. This section includes a discussion of gauges, switches, machine controls, accessories and transportation.

Photographs and illustrations guide the operator through correct procedures of setting up, checking and operating the machine.

Operating techniques outlined in this publication are basic. Proficiency develops as the operator gains knowledge and experience with the machine and its capabilities.

## Maintenance

The maintenance section is a guide to equipment care. The maintenance schedule lists the items to be maintained at a specific service interval. Items without specific intervals are listed under the "As Needed" service interval. The schedule lists the page for the step-by-step instructions required to accomplish the scheduled maintenance. Use the schedule as an index for all maintenance procedures.

Some maintenance procedures may be referenced in a manual pertaining to that component of the machine. For example, maintenance for an engine component would have its intervals and procedures in the engine operator's manual.

Use the hour meter (if equipped) to determine servicing intervals. Calendar intervals will be used instead of hour meter intervals if no hour meter is equipped on a machine. Recommended service should always be performed at the interval that occurs first.

Under extremely severe, dusty or wet operating conditions, more frequent lubrication than is specified in the maintenance schedule might be necessary.

## Asahi/America Training Standards

Since 1984, Asahi/America, Inc. has been teaching contractors the benefits of welding thermoplastic piping systems in industrial and high purity applications. Our partnership with McElroy allows us to leverage their state-of-the-art Learning Management System (LMS) using Asahi/America technical standards across all Asahi piping systems.

For more than 30 years, McElroy has been the only pipe fusion machine manufacturer to continuously offer advanced training. Course offerings are meant to enhance your efficiency, productivity and safety in the proper use of McElroy machines. Asahi/America learning portal classes powered by McElroy University are structured so that the skills learned and the machines used in each class closely match the machines found on pipelining jobsites.

Training modules specific to Asahi/America piping systems available for purchase online and required to be completed prior to onsite training by Asahi/America personnel.

This manual is intended as a guide only and does not take the place of proper training by qualified instructors. The information in this manual is not all inclusive and cannot encompass all possible situations that can be encountered during various operations.

## Patent Information

This product and other products could be protected by patents or have patents pending. All the latest patent information is available at [patent.mcelroy.com](http://patent.mcelroy.com)

## Replacement Literature

This product is shipped with a printed operator's manual. If the manual becomes lost or damaged, order a replacement manual or download and print a copy of the manual at [www.mcelroy.com](http://www.mcelroy.com).

## Nameplate Locations

Every machine has a name plate that includes the machine's model number, serial number, and power requirements. The model and serial numbers can be used to register the machine online and activate the warranty. Reference warranty card for information on registering your product.

## Replacement Parts

Refer to the McElroy parts finder at [www.mcelroy.com](http://www.mcelroy.com) to locate parts for purchase. Reference the model number on the nameplate of the machine when using the parts finder. Contact your McElroy distributor to order replacement parts. Find your closest distributor on our website at [www.mcelroy.com](http://www.mcelroy.com).

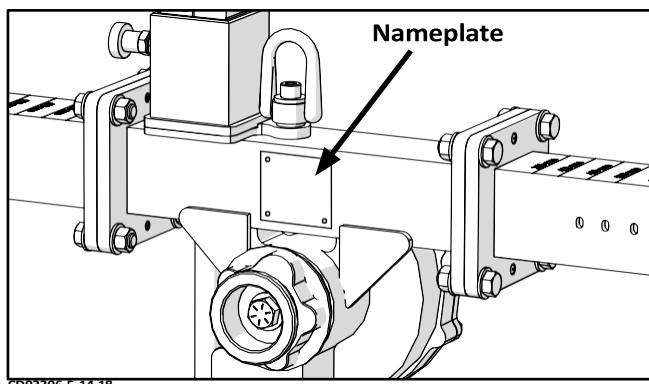
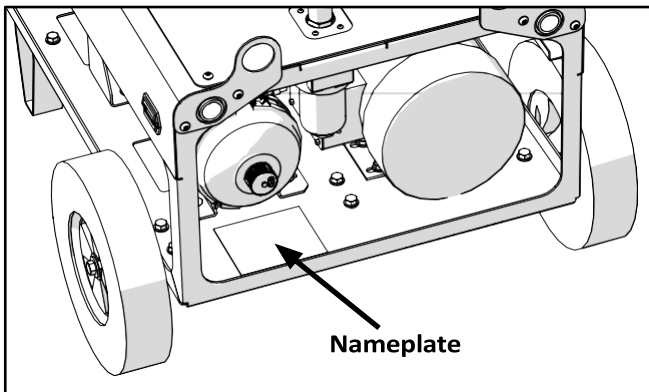



---

---

## Asahi/America Rental Warranty

Asahi/America's comprehensive rental equipment policies can be found on our website here: <https://www.asahi-america.com/support/rental-equipment-policy>

All rental equipment is warranted for six (6) months of on-site usage. All tool failures within this six-month period are handled as indicated in Section V. After six months usage it is recommended that the equipment be returned for regular maintenance and warrantee renewal. Equipment held longer than six months without return is held at the renter's risk.

## Used Equipment Warranty

Purchase of refurbished/used equipment carries a 90-day warranty.

## New Equipment Warranty

Purchase of new Asahi/America versions of McElroy equipment carries a 5-year limited warranty. Details can be found here: <https://www.mcelroy.com/warranty.htm>

# SAFETY

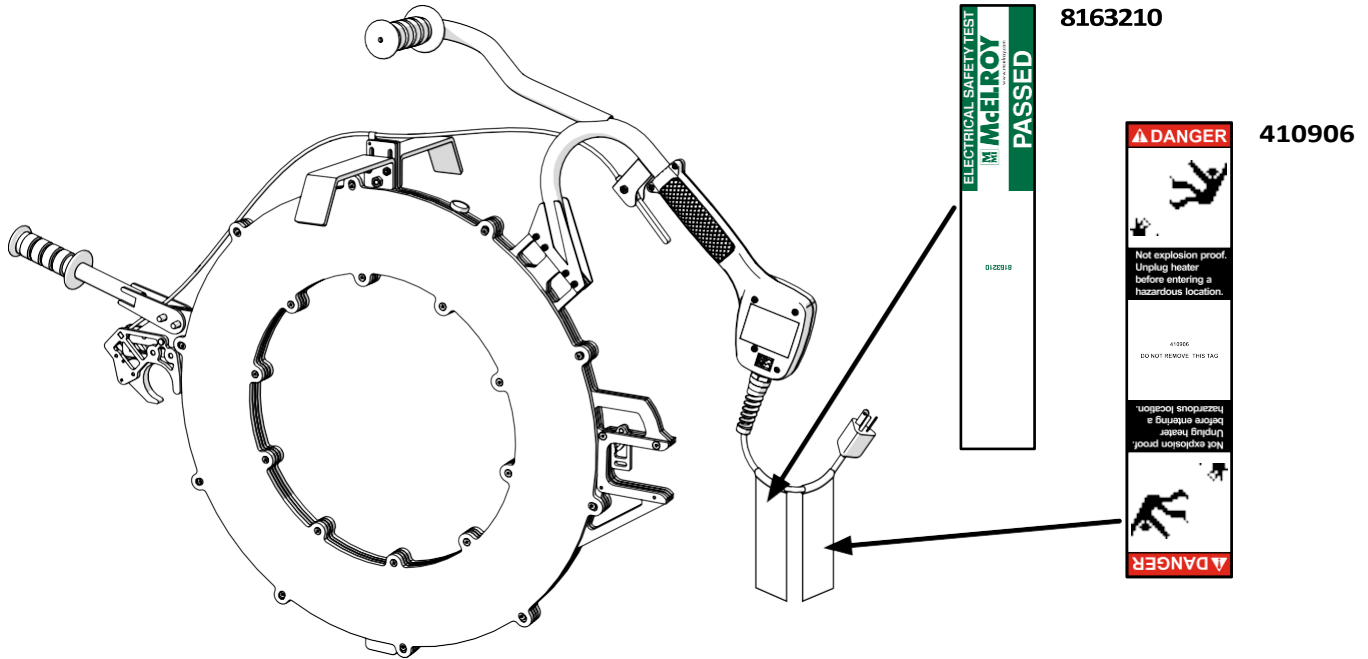

CD02310-6-14-18

There can be several specific safety messages on this machine. The exact location of the hazards and the description of the hazards are reviewed in this section. Please become familiarized with all safety messages.

Make sure that all of the safety messages on the machine are legible. Clean the safety messages or replace the safety messages if you cannot read the words. Replace if the illustrations are not legible. When you clean the safety messages, use a cloth, water and soap. Do not use solvent, gasoline, or other harsh chemicals to clean the safety messages. Solvents, gasoline, or harsh chemicals could loosen the adhesive that secures the safety message or damage the print of the safety message.

Replace any safety message that are damaged, or missing. If a safety message is attached to a part that is replaced, install a safety message on the replacement part. New safety messages can be ordered from McElroy using the part number listed.

## General Safety

Safety is important. Report anything unusual that you notice during set up or operation.

**LISTEN** for thumps, bumps, rattles, squeals, air leaks, or unusual sounds.

**SMELL** odors like burning insulation, hot metal, burning rubber, hot oil, or natural gas.

**FEEL** any changes in the way the equipment operates.

**SEE** problems with wiring and cables, hydraulic connections, or other equipment.

**REPORT** anything you see, feel, smell, or hear that is different from what you expect, or that you think may be unsafe.



SAFE1ST-2-21-18

## Safety Equipment

Wear a hard hat, safety shoes, safety glasses, and other applicable personal protective equipment.

Remove jewelry and rings, and do not wear loose fitting clothing or long hair that could catch on controls or moving machinery. Remove any loose safety equipment during an operation that could be drawn into or caught in the machine.

Ensure proper fire prevention or other fire-fighting equipment is available and all personnel know how and when to use it.

# Heater Is Not Explosion

This safety message is located on the cord of the heater.



This heater is not explosion proof. Operation of heater in an explosive atmosphere without necessary safety precautions will result in serious injury or death.

When operating in an explosive atmosphere, the heater should be brought up to temperature in a safe environment, then unplugged before entering the explosive atmosphere for fusion.



WR00080-2-21-18

# Electric Motors are Not Explosion Proof



Electric motors are not explosion proof. Operation of these components in an explosive atmosphere without necessary safety precautions will result in serious injury or death.

The facer drill motor cannot be used manually and must not be used in an explosive atmosphere.



WR00080-2-21-18

WR00080-4-12-93

# Overhead Loads



The QuikFit™ fusion carriage is not designed to support overhead or overhung loads. Adequately support the pipe using appropriate support devices. If not supported, overhead loads could fall causing serious injury or death.

Unclamping jaws in an overhead position could have jaws swing into the head resulting in serious injury or death. Support the carriage when attaching or removing the carriage to pipe.

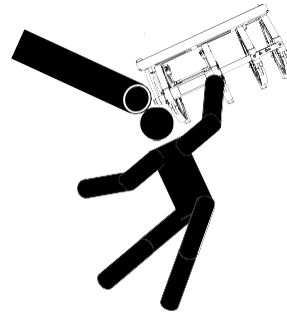

WR00102-5-14-18

# Electrical Safety



Always ensure equipment is properly grounded. It is important to remember that if you are working in a wet environment with electrical devices. Proper ground connections help to minimize the chances of an electric shock.

Frequently inspect electrical cords and unit for damage. Have damaged components replaced and service performed by a qualified electrician.

Do not carry electrical devices by the cord

**NOTICE:** Always connect units to the proper power source as listed on the unit, or in the owner's manual. Use GFCI electrical connections when available.



WR00055-6-14-18

## Units With Hydraulics

It is important to remember that a sudden hydraulic oil leak can cause serious injury, or even be fatal if the pressure or oil temperature is high enough.

### ⚠️ WARNING

Escaping fluid under pressure can penetrate the skin causing serious injury. Keep hands and body away from pinholes which eject fluid under pressure. Use a piece of cardboard or paper to search for leaks. If any fluid is injected into the skin, it must be immediately removed by a doctor familiar with this type of injury.

Unwanted movement of the machine could result in serious injury or damage to machine. Unwanted movement of the machine may take place if switches do not match machine state when the machine power is turned on.

**NOTICE:** Wear safety glasses, and keep face clear of area when bleeding air from hydraulic system to avoid spraying oil into eyes.



WR00078-5-14-18

## Crush Points

### ⚠️ WARNING

Hydraulically operated jaws are operated under pressure. Anything caught in the jaws will be crushed. Keep all body parts out of the jaw area. Always check pipe alignment with a pencil or similar object.



WR00012-5-14-18

## Carriage Handling

### ⚠️ WARNING

Disconnect carriage from HPU before attaching carriage to pipe. Carriage is operated remotely and remote operation could result in minor to moderate injury.

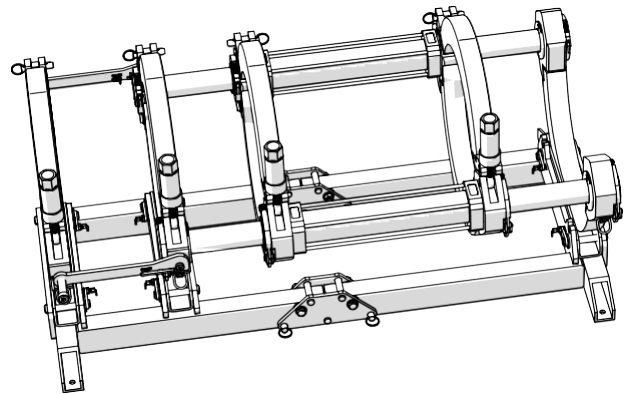

CD02243-6-14-18

## Facer Blades Are Sharp

### ⚠️ WARNING

Facer blades are sharp and can cut. Never attempt to remove shavings while the facer is running, or is in the facing position between the jaws. Use care when operating the facer, and when handling the unit.

**NOTICE:** Never extend the facer blades beyond the inner or outer circumference of the facer.



WR00073-2-21-18

## Lifting Safety

Follow all applicable federal, state, local, and industry specific regulations when lifting.

### ⚠ WARNING

Safety warnings:

1. Do not exceed rated load or lift loads greater than the rated load of the lifting device.
2. Do not operate a damaged or malfunctioning lifting device.
3. Do not lift persons.
4. Do not lift a suspended load over persons.
5. Do not leave a suspended load unattended.
6. Do not remove or obscure warning labels.
7. Read and understand the lifting device operator's manual before use.
8. Stay clear of the suspended load.
9. Lift loads only as high as necessary.
10. Do not alter or modify the lifting device.
11. Employ generally accepted safe lifting practices.
12. Do not shock or impact load the lifting device.
13. Inspect all lifting pins for damage.



WR00014-5-21-18

## Personal Lifting Safety

### ⚠ CAUTION

The machine components are heavy. Using one person to lift the facer or carriage may result in an injury. Use a lifting strap and an overhead lifting device to lift facer or carriage. For manual lifting, two people are required to lift the facer or carriage.

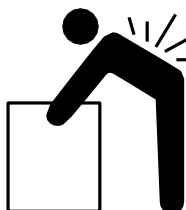

HeavyLifting-5-21-18

## Heater is Hot

### ⚠ CAUTION

The heater is hot and will burn clothing and skin. Keep the heater in its insulated heater stand or blanket when not in use, and use care when heating the pipe.

**NOTICE:** Use only a clean dry lint free non-synthetic cloth to clean the heater plates.



WR00030-2-21-18

## Sound Information

The operator Equivalent Sound Pressure Level is 92 dB(A). This is measured from the operator location at the machine. The distance of the measurement is 40" (102cm) from the machine.

Hearing protection may be needed when the machine is operated during facing or in a noisy environment.

## Fusion Procedures

Obtain a copy of the pipe manufacturer's fusion procedures or appropriate joining standard for the pipe being fused. Follow the procedure carefully, and adhere to all specified parameters.

**NOTICE:** Failure to follow the pipe manufacturer's fusion procedures or appropriate joining standard could result in a bad fusion joint.

## Do Not Modify Machine

Make no modifications to your equipment unless specifically recommended or requested by McElroy.

# GENERAL INFORMATION

---

## Theory of Butt Fusion

The principle of heat fusion is to heat two pipe surfaces to a designated temperature, and then fuse them together by application of force. This develops pressure which causes flow of the melted materials, which causes mixing and thus fusion. When the thermoplastic material is heated, the molecular structure is transformed into an amorphous condition. When fusion pressure is applied, the molecules from each thermoplastic part mix. As the joint cools, the molecules return to their form, the original interfaces are gone, and the fitting and pipe have become one monolithic unit. A strong, fully leak tight connection is the result.

The principal operations include:

- Clamping** The pipe pieces are held axially and radially to allow all subsequent operations to take place.
- Facing** The pipe ends are faced to establish clean, parallel mating surfaces perpendicular to the centerline of the pipes.
- Aligning** The pipe ends are aligned with each other to minimize mismatch of the pipe walls.
- Heating** A melt pattern that penetrates into the pipe is formed around both pipe ends.
- Fusing** The melt patterns are joined with a specified force, which is constant around the pipe interfacial area.
- Cooling** The fusion joint is held immobile with a specified force until adequately cooled.
- Inspecting** Visually examine the entire circumference of the joint for compliance with the standard or fusion procedure used.



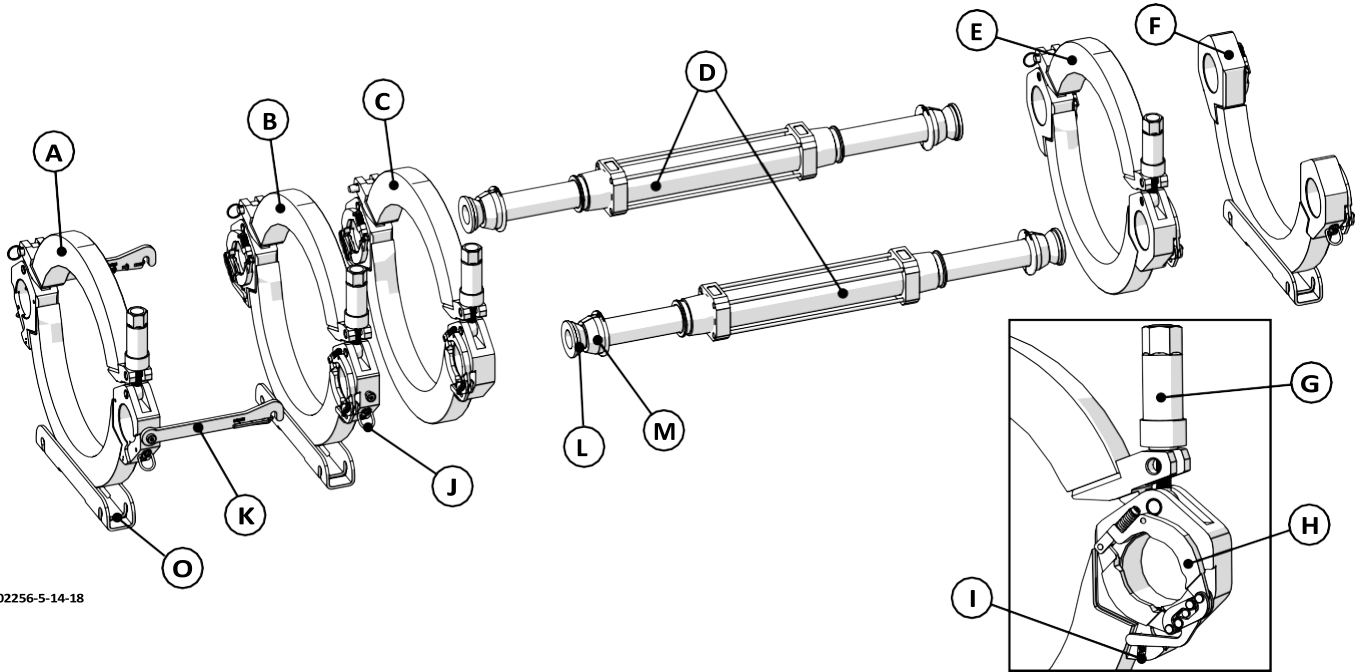

CD02256-5-14-18

General Information

## Nomenclature

### QuikFit™ Carriage Assembly

#### A - Outer Fixed Jaw

Jaw that consists of a upper and lower jaw used to clamp to pipe. Has jaw braces that connect to the inner fixed jaw.

#### B - Inner Fixed Jaw

Jaw that consists of a upper and lower jaw used to clamp to pipe. Jaw clamps to cylinder assembly.

#### C - Inner Movable Jaw

Jaw that consists of a upper and lower jaw used to clamp to pipe. Jaw clamps to cylinder assembly.

#### D - Cylinder Assemblies

Movable jaws move along guide rods due to hydraulic pressure. Cylinder assemblies connect to a Hydraulic Power Unit.

#### E - Outer Movable Jaw

Jaw that consists of a upper and lower jaw used to clamp to pipe. Jaw clamps to cylinder assembly.

#### F - Guide Rod Support

Support the movable jaw end of carriage. Guide rod support clamps to cylinder assembly.

#### G - Jaw Clamp Knob

Tightens to clamp the upper and lower jaws around pipe.

#### H - Cylinder Clamp

Clamps lower jaw to cylinder assembly.

#### I - Latch Clip

Latches cylinder clamp handle to prevent unclamping.

#### J - Lift Ring

Use to lift/support carriage vertically or overhead.

#### K - Jaw Brace

Brace that connects between inner fixed jaw and outer fixed jaw.

#### L - Rod Cap

Screws into end of cylinder assemblies. Used to adjust clamping tension.

#### M - Guide Rod Sleeve

Used as a stop for jaw when clamped to cylinder assemblies.

#### O - Carriage Skid Mounting Slots

Skid locking pins slide into slots to mount carriage to skid.

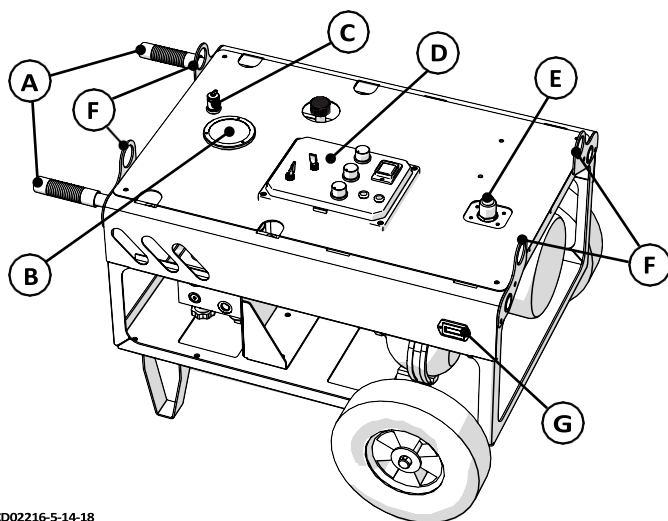

CD02216-5-14-18

## Large Acrobat™ Hydraulic Power Unit (HPU)

### A - HPU Handles

Used to lift up the HPU so it may be rolled.

### B - Hydraulic Pressure Gauge

Displays hydraulic pressure for selected pressure setting on control box.

### C - DataLogger® Port

Connect a DataLogger® to HPU.

### D - HPU Fusion Control Box

Contains controls to adjust pressure, select pressure modes and operate carriage. Control box has an on/off switch and circuit breakers.

### E - Filter Bypass Indicator

Indicates if hydraulic system is bypassing hydraulic filter. If bypassing, replace filter.

### F - HPU Lift Points

Four lift points at each corner of HPU. Use a sling with hooks attached to a overhead lifting device to lift HPU.

### G - Hour Meter

Displays number of hours HPU has been in operation.

### H - Electrical Receptacles

Two receptacles for powering facer drive unit and heater. The left receptacle is for facer drive unit and the right receptacle is for heater.

### I - Hydraulic Fluid Dipstick

Has a HIGH fluid indicator and is also the fill location.

### J - Pressure Selector Switch

Select between facing, heating and fusing pressure modes.

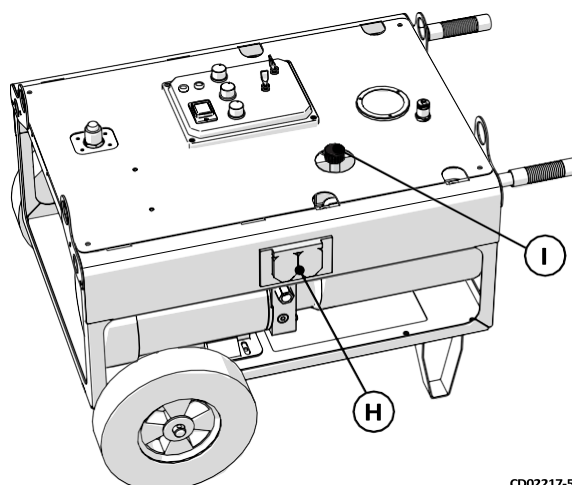

CD02217-5-14-18

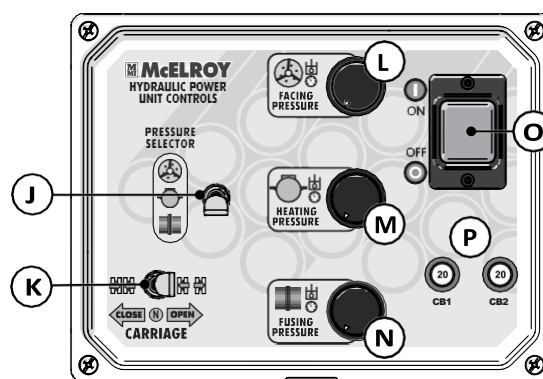

CD02218-5-14-18

### K - Carriage Control Switch

Used to open or close carriage or set to a neutral position.

### L - Facing Pressure Adjustment Knob

Used to adjust facing pressure when pressure selector switch is set to facing.

### M - Heating Pressure Adjustment Knob

Used to adjust heating pressure when pressure selector switch is set to heating.

### N - Fusing Pressure Adjustment Knob

Used to adjust fusing pressure when pressure selector switch is set to fusing.

### O - HPU Power Switch

Toggles the HPU power on/off.

### P - Circuit Breakers

Two 20A circuit breakers. The center of breaker will extend outward when tripped.



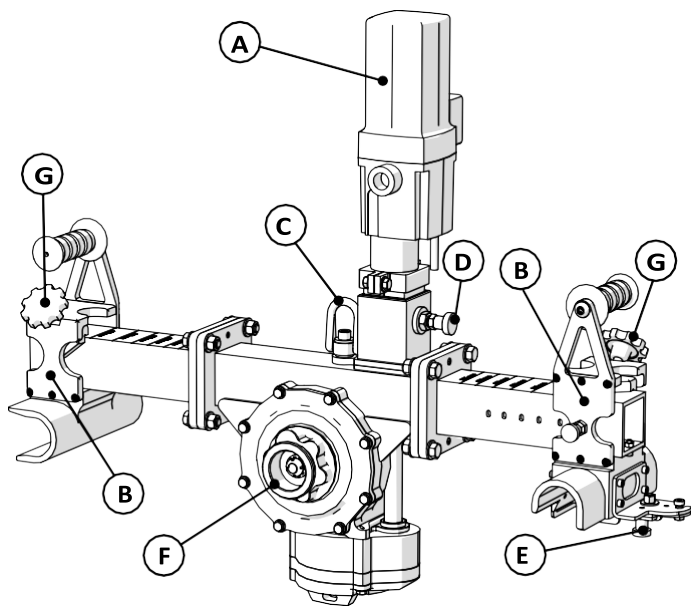

CD02206-5-14-18

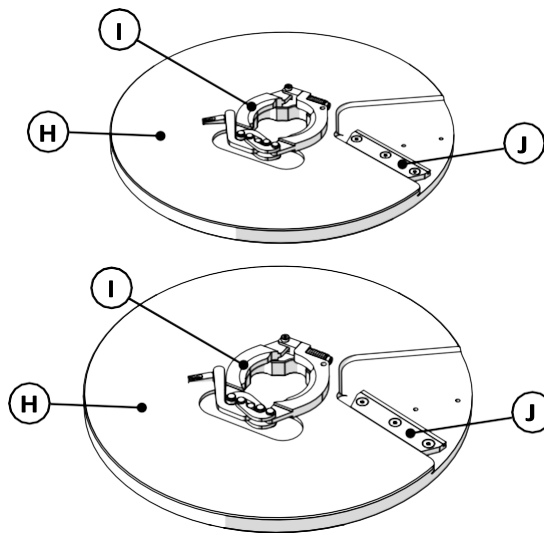

CD02207-5-14-18

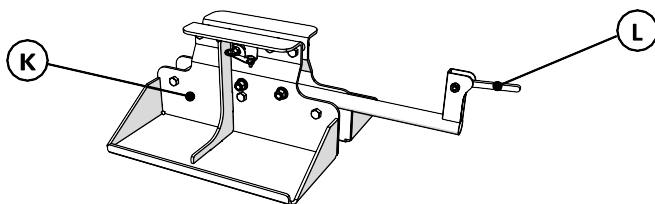

CD02209-05-14-18

## Facer Drive Unit

### A - Facer Drive Motor

Motor that drives gearbox of facer.

### B - Adjustable Guide Rod Bracket Assemblies

Vertical and horizontal brackets that are adjustable to guide rod widths.

### C - Facer Lift Point

Used to lift the facer drive unit.

### D - Facer Drive Motor Release Plunger

Releases the drive motor from gearbox.

### E - Guide Rod Latch

Plunger releases guide rod latch so it may be rotated and facer lifted from guide rod.

### F - Facer Blade Holder Drive Hub

Facer blade holders attach to the drive hubs on both sides of the gearbox.

### G - Guide Rod Bracket Assembly Position Knob

Used to tighten and lock position of guide rod brackets.

### H - Facer Blade Holder

Holds facer blade and mounts on blade holder drive hub.

### I - Blade Holder Clamp

Used to clamp the facer blade holder to drive hub.

### J - Facer Blade

Used to cut thin ribbons of pipe material.

### K - Facer Drive Unit Stand

Stand for the facer drive unit. Stand also mounts to heater/ facer cart.

### L - Facer Drive Unit Stand Release Lever

Used to release the facer drive unit from stand.

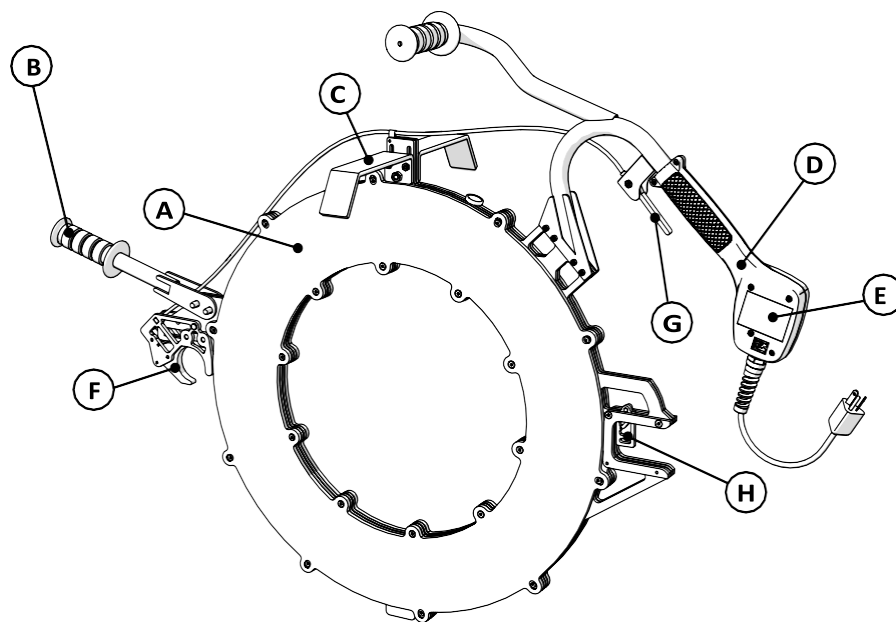

CD02208-6-14-18

## Heater

### A - Heater Butt Plate

Non-stick coated plates that attach to the heater body.

### B - Secondary Heater Handle

Handle used to hold the heater from opposite side of primary handle.

### C - Heater Stripper Bar

Used to mechanically separate heater from pipe during fusion.

### D - Primary Heater Handle

Location to hold the heater and has a potentiometer to adjust the heater temperature.

### E - Heater Information Label

Provides model number, power and indicator light information.

### F - Heater Guide Rod Latch

Mechanically lock the heater to the guide rod of carriage. Has two position for both carriage sizes.

### G - Guide Rod Latch Release Lever

Opens guide rod latch releasing heater from guide rod.

### H - Guide Rod Adjustment Block

Rotate down for use with larger size carriage, rotate up for smaller size carriage.

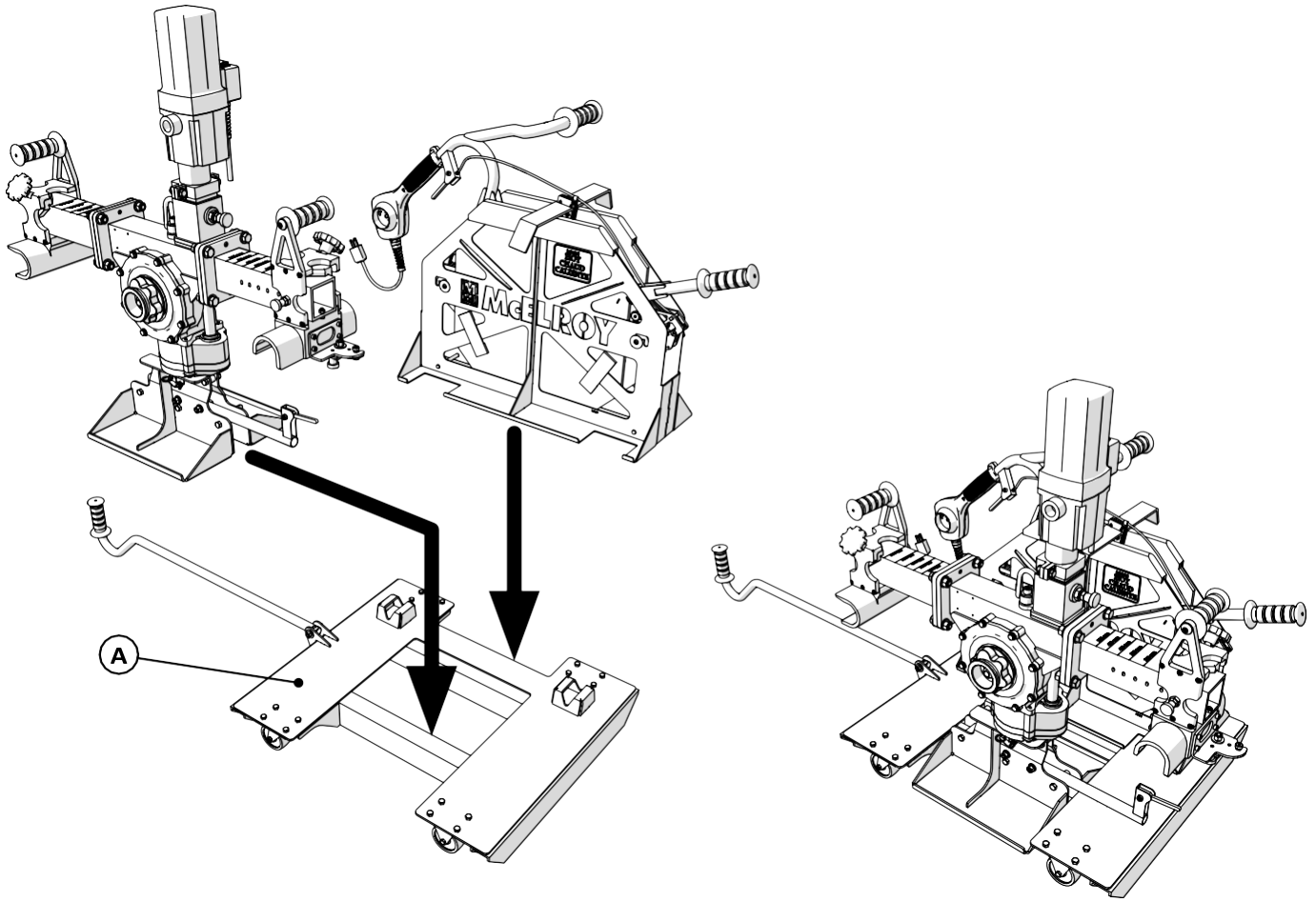

CD02258-6-4-18

CD02211-5-14-18

## Heater/Facer Cart

### A - Heater/Facer Cart

Wheeled cart used to move facer drive unit and heater and heater bag.

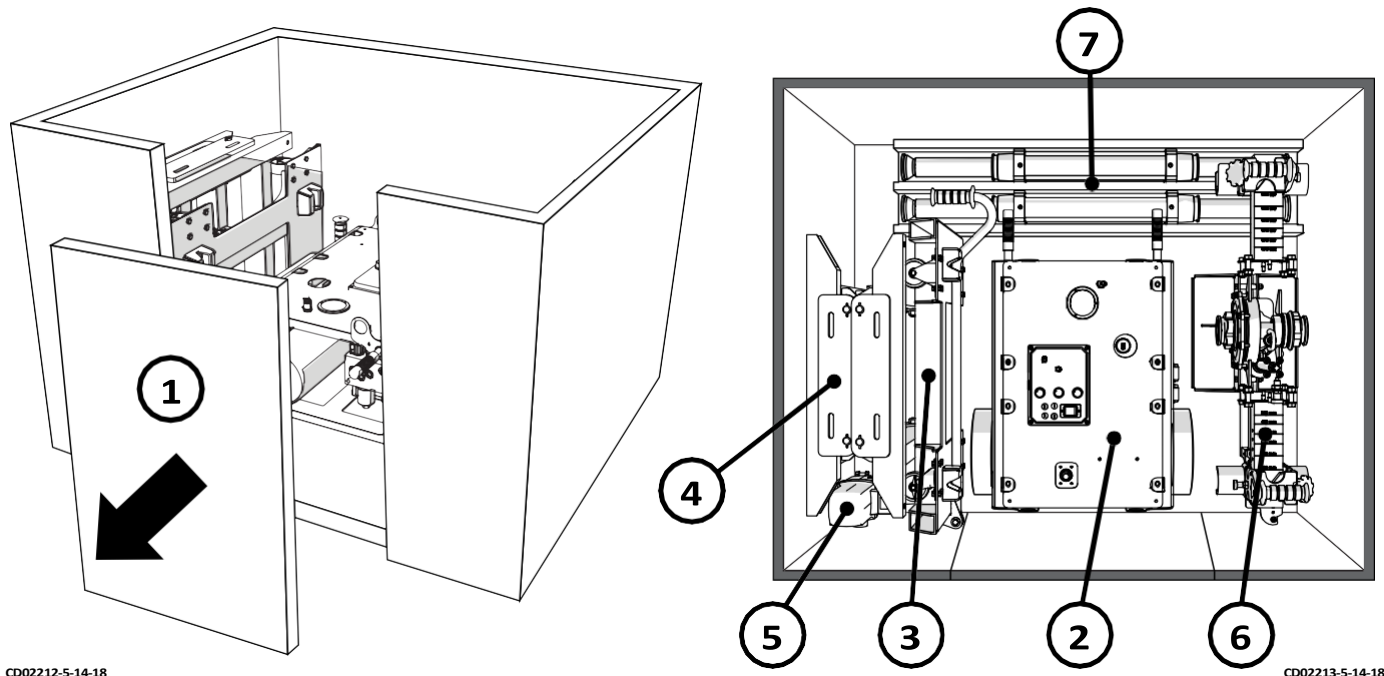

CD02212-5-14-18

CD02213-5-14-18

## Unpack Acrobat™ Packages

### Unpack Core Package:

- 1) Remove front panel of crate.
- 2) Roll HPU out of crate through front panel opening.
- 3) Remove heater/facer cart from crate.
- 4) Remove carriage skid.
- 5) Remove facer drive motor.
- 6) Remove facer drive unit from crate. Use a two man lift or use lift point to lift using an overhead lifting device. The facer can be loaded onto cart for transport.
- 7) Remove both cylinder assemblies.

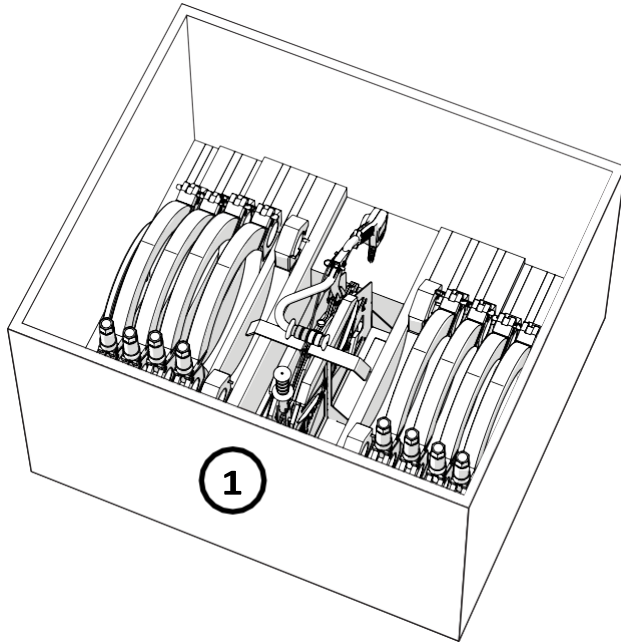

CD02214-5-14-18

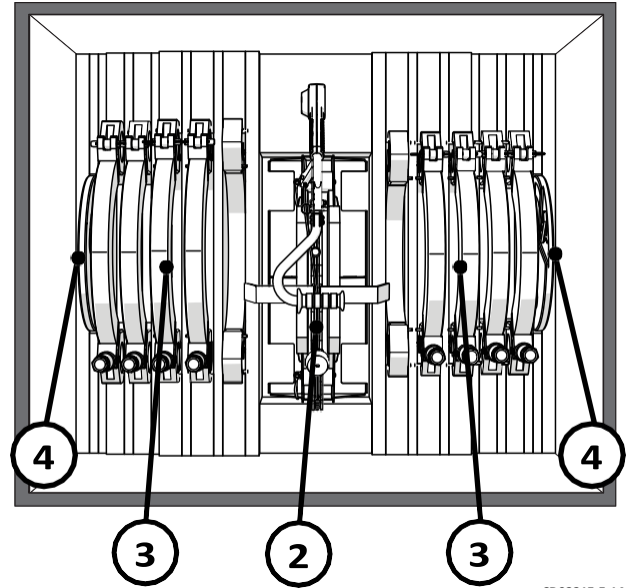

CD02215-5-14-18

## Unpack Heater/Jaw Package:

- 1) Open heater/jaw package crate.
- 2) Remove heater and heater bag. Heater and heater bag can be placed on heater/facer cart for transport.
- 3) Remove the jaw set size to be used for fusion.
- 4) Remove both facer blade holders.

Install second clamp on opposite side of jaw.

## Install Jaw Cylinder Clamps

- 1) Position clamp together as shown.

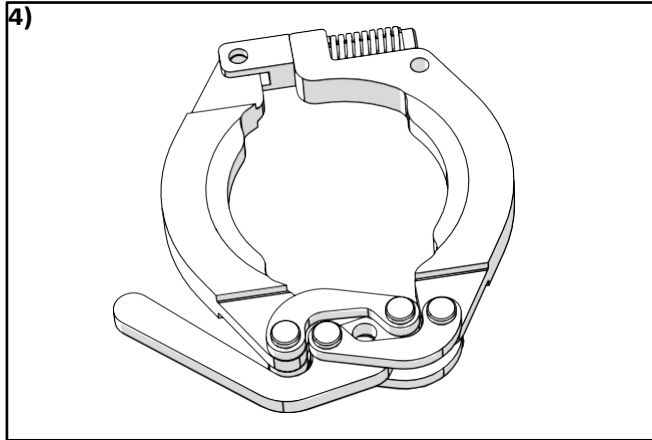

- 2) Slide clamp over two pins on jaw.

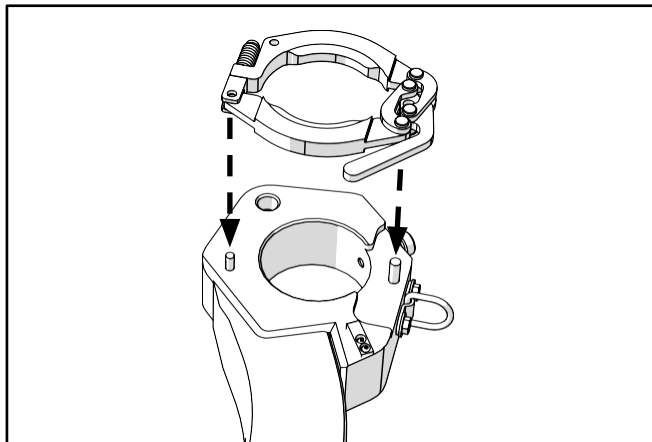

- 3) Ensure clamp is seated completely against jaw.

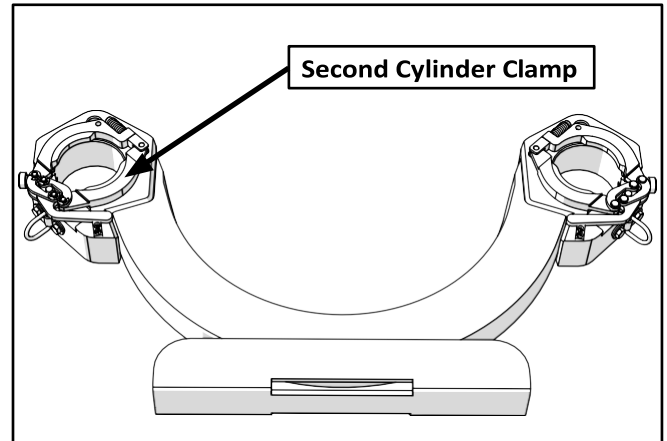
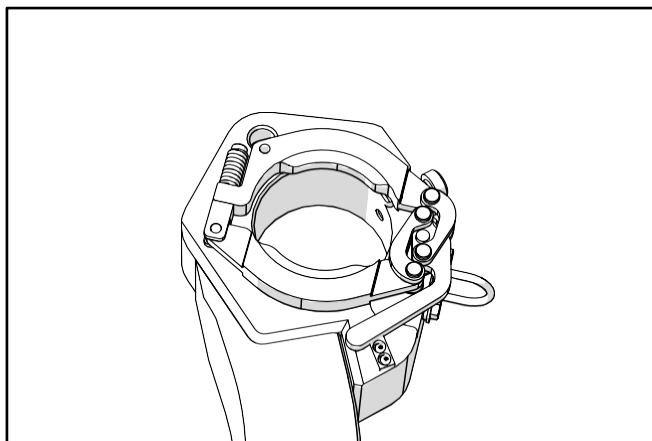

- 5) Install clamps on other jaws with two pins around guide rod holes. The lower jaws that will need clamps installed are: inner fixed jaw, inner and outer movable jaws, and guide rod support.

# Assemble QuikFit™ Carriage

- 1) Position hydraulic cylinders parallel to each other. Slide a movable jaw over cylinder guide rods and flush against cylinder caps.

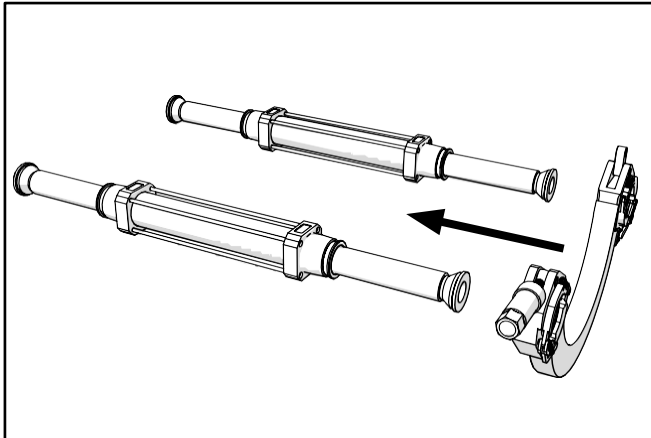

CD02223-6-14-18

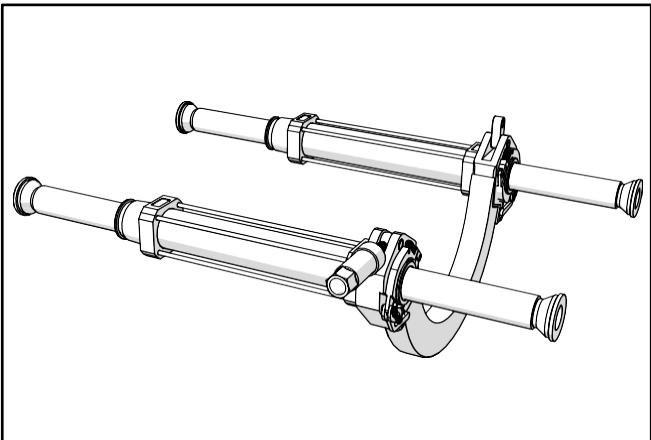

CD02224-6-14-18

- 2) Close clamp handle completely. Ensure clamp handle goes over and past handle stop. Perform the same action on opposite clamp.

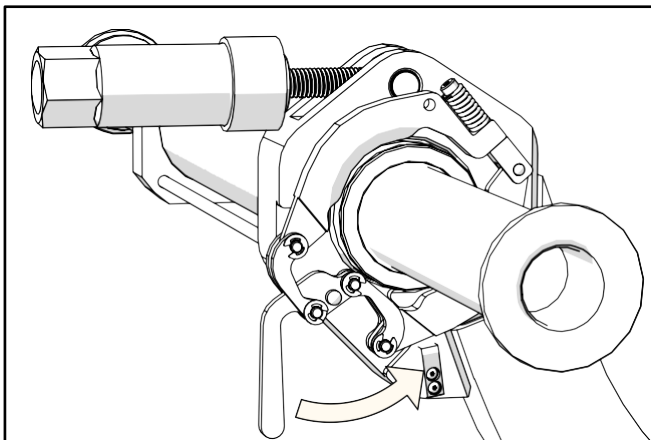

CD02225-6-14-18

- 3) Slide second movable jaw over cylinder guide rods and flush against cylinder caps. Close both cylinder clamps on jaw.

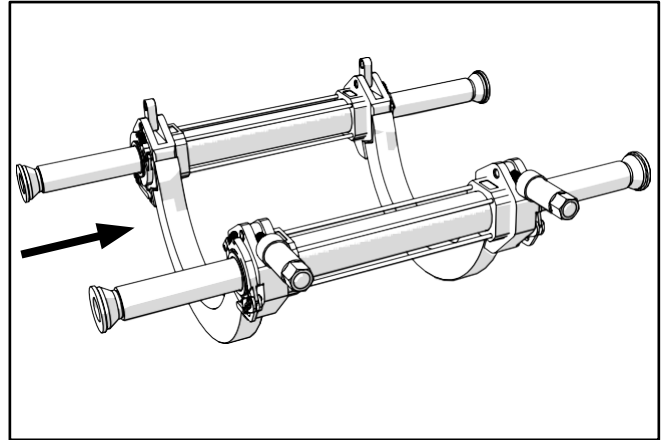

CD02226-6-14-18

- 4) Position two guide rod sleeves (A) on end of guide rods.

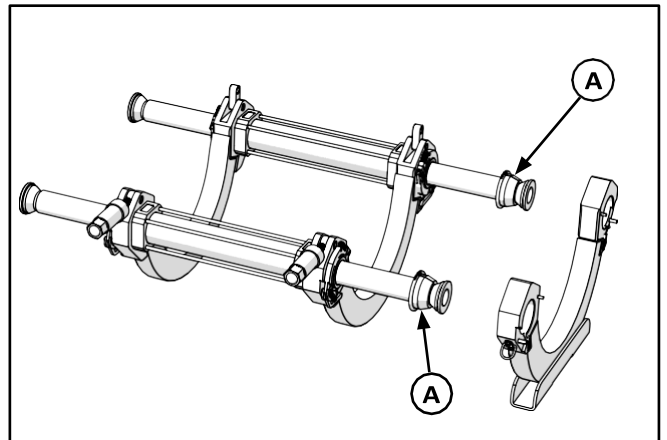

CD02227-6-14-18

- 5) Slide guide rod support over cylinder guide rods and flush against guide rod sleeves.

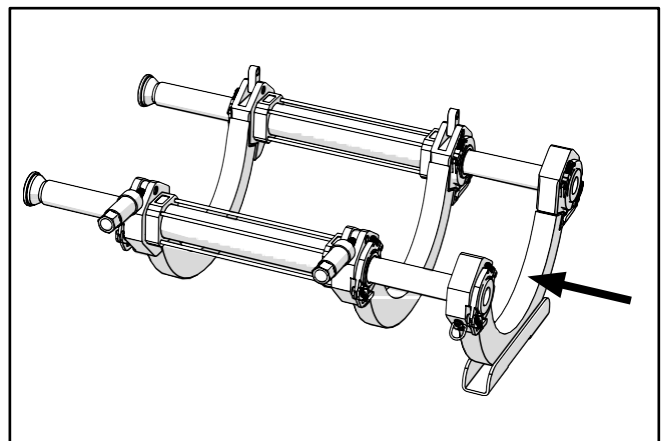

CD02228-6-14-18

6) Rotate the guide rod caps (B) to adjust clamping tension. Adjust guide rod caps until clamps close firmly.

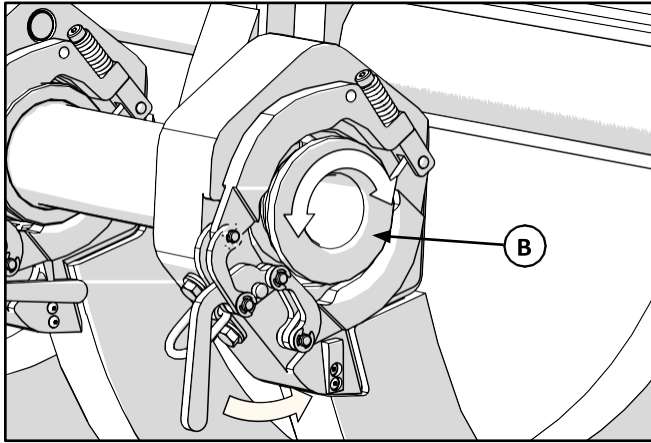

9) Rotate the guide rod caps (D) to adjust clamping tension. Adjust guide rod caps until clamps close firmly.

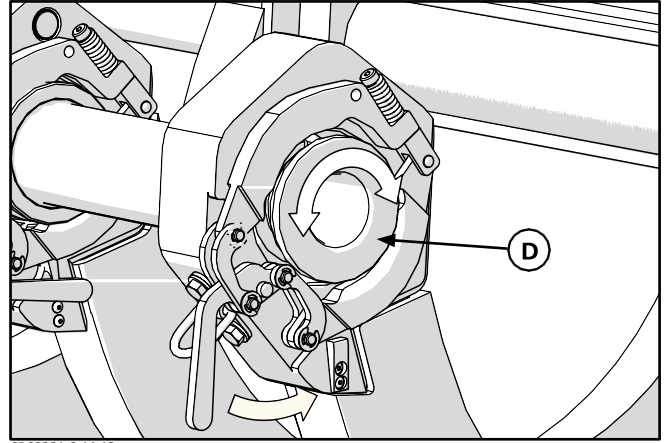

7) Position two guide rod sleeves (C) on end of guide rods.

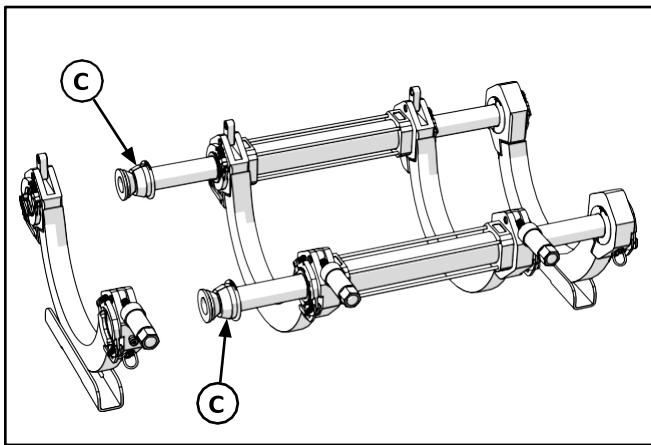

10) Attach the upper jaws to lower jaws using pins (E).

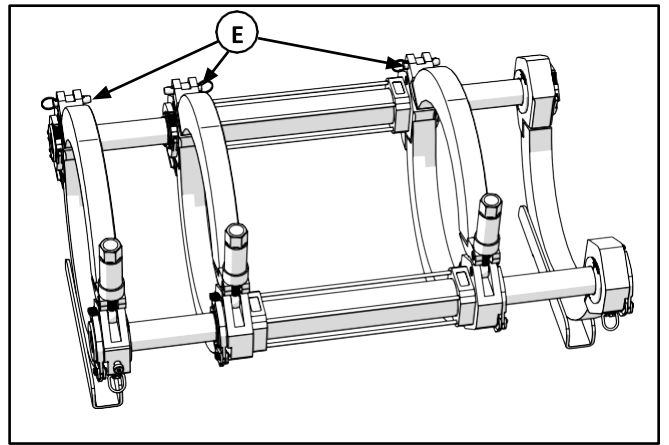

8) Slide fixed jaw over cylinder guide rods and flush against guide rod sleeves.

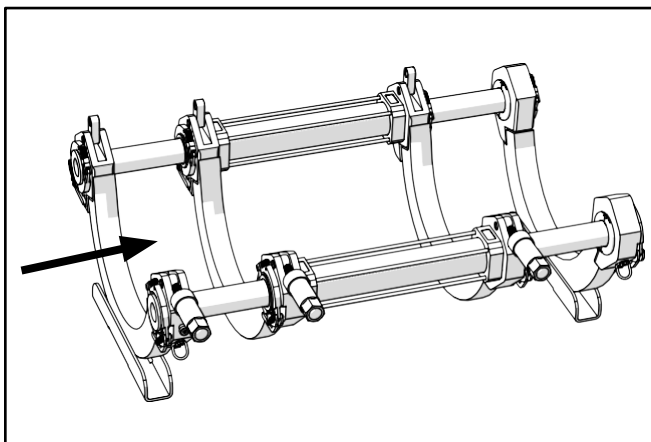



## Attach Outer Fixed Jaw and Skid to QuikFit™ Carriage:

1) Position skid as shown.

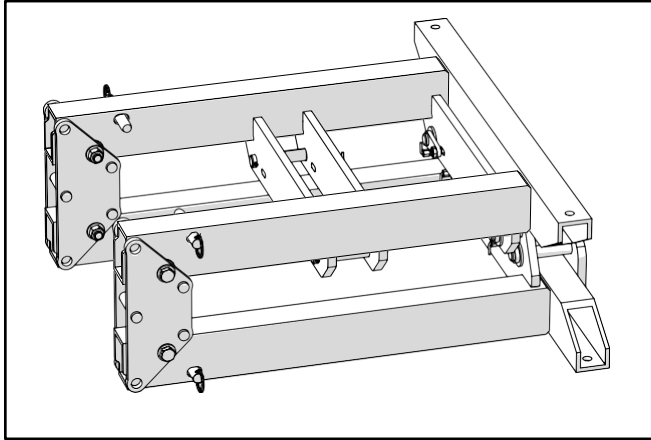

CD02259-6-14-18

2) Remove four pins (A) at end of skid.

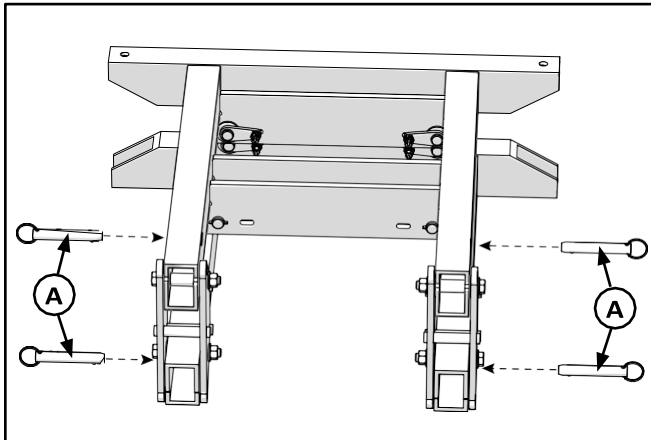

CD02261-6-14-18

3) Rotate two locking pins (B) 180° to unlock.

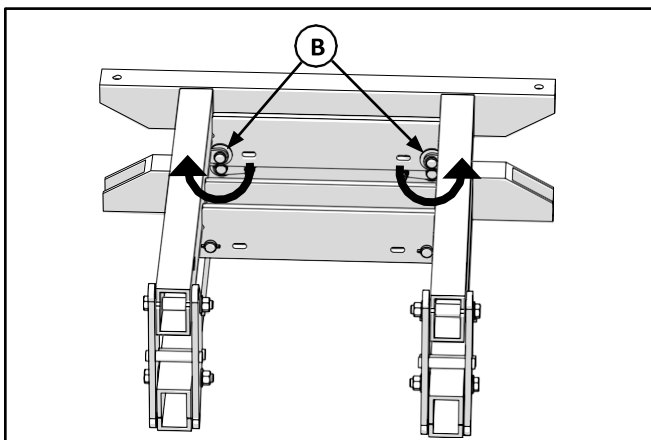

CD02262-6-14-18

4) Rotate half of skid up.

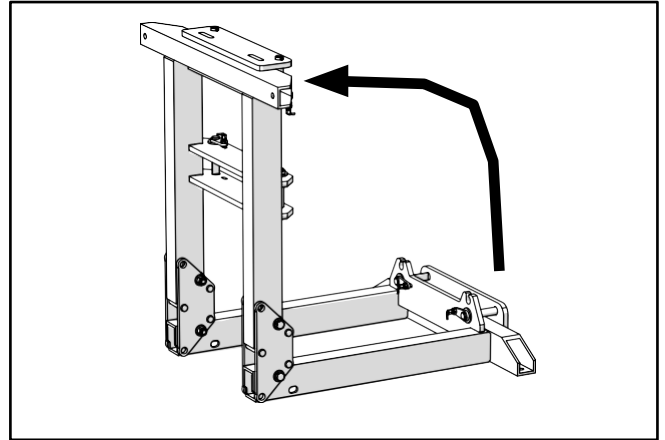

CD02263-6-14-18

5) Continue to rotate half of skid over until skid lays flat. Insert four pins (C) into skid.

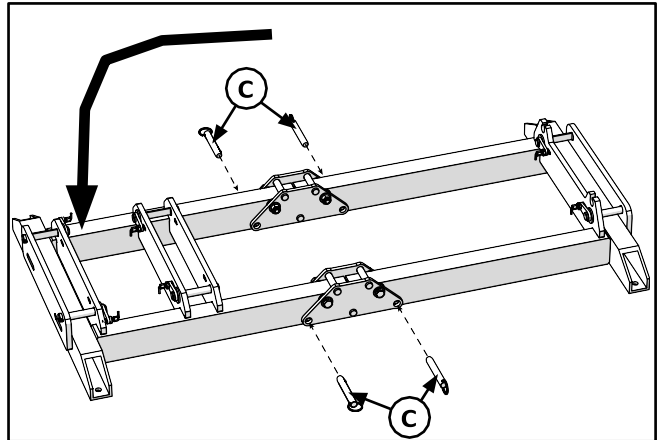

CD02265-6-14-18

6) Rotate all locking pins (D) 180° to unlock. Ensure plungers are not in slot.

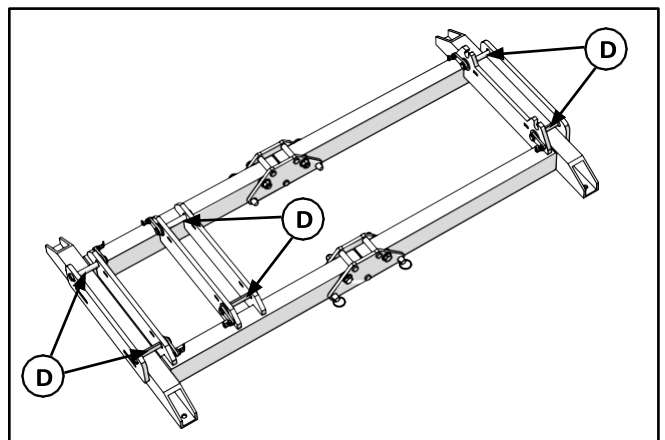

CD02240-6-14-18

7) Position 3 jaw carriage onto skid.

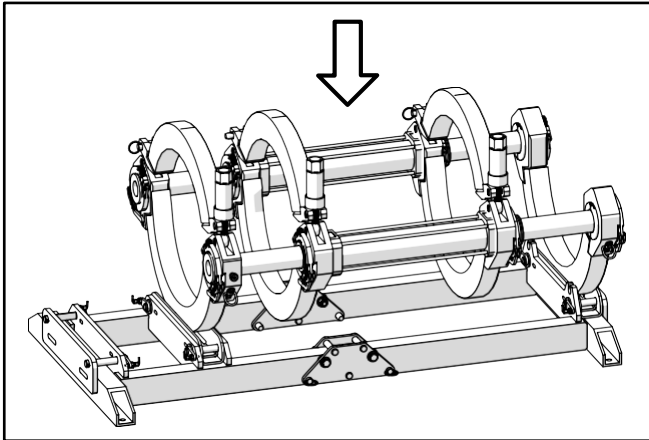

CD02267-6-14-18

8) Position outer fixed jaw at end and rotate down jaw braces (E) until they connect with inner fixed jaw.

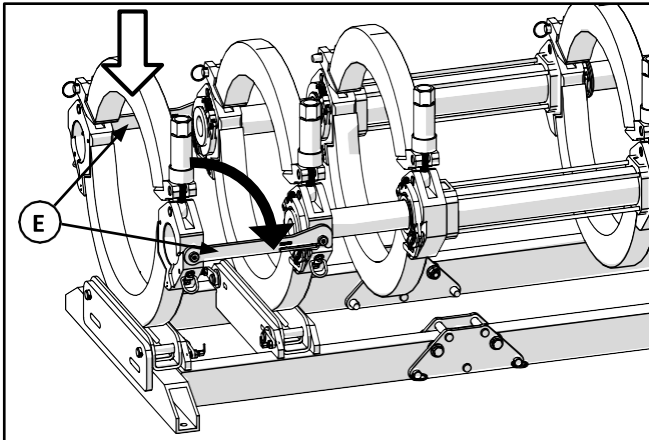

CD02268-6-14-18

9) Rotate all locking pins (F) 180° to lock carriage to skid. Ensure locking pins locks into slot.

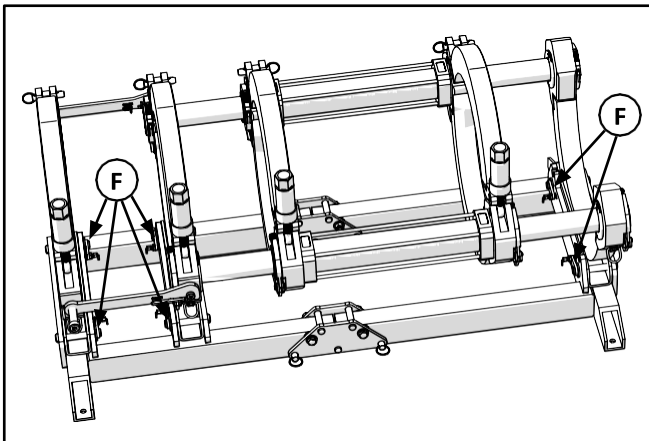

CD02243-6-14-18

# Assemble Facer Drive Unit

- 1) Insert drive motor into facer drive unit. Align drive motor hole with plunger on facer drive unit (A).

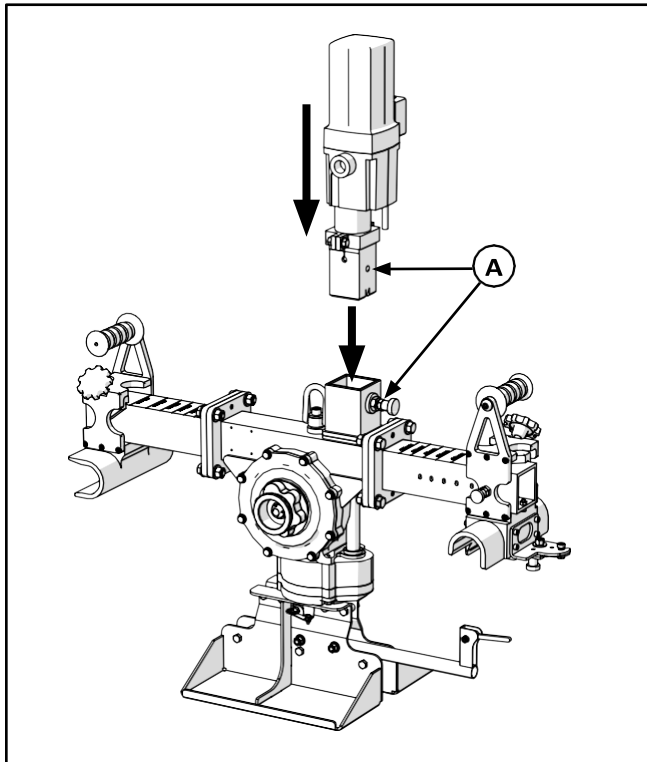

CD02244-6-14-18

- 2) Place blade holders onto drive hubs. Close clamps on blade holders to lock them to drive hubs. One blade holder has 5 points and the other has 6 points. They match the respective point drive hub.

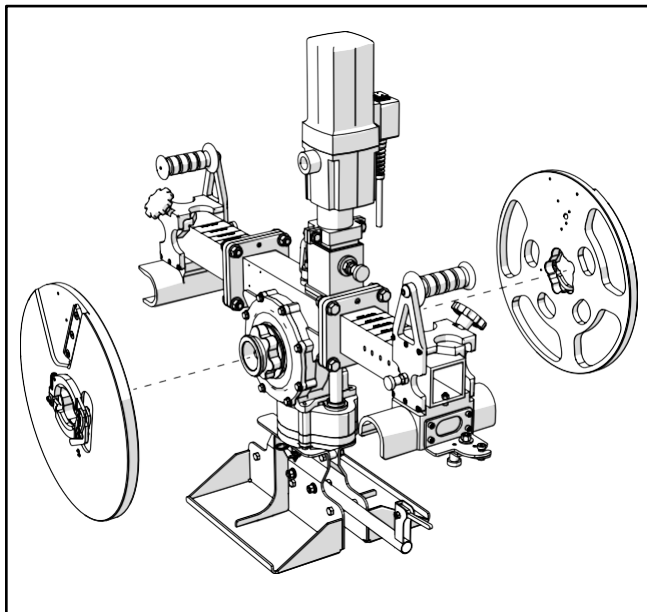

CD02245-6-14-18

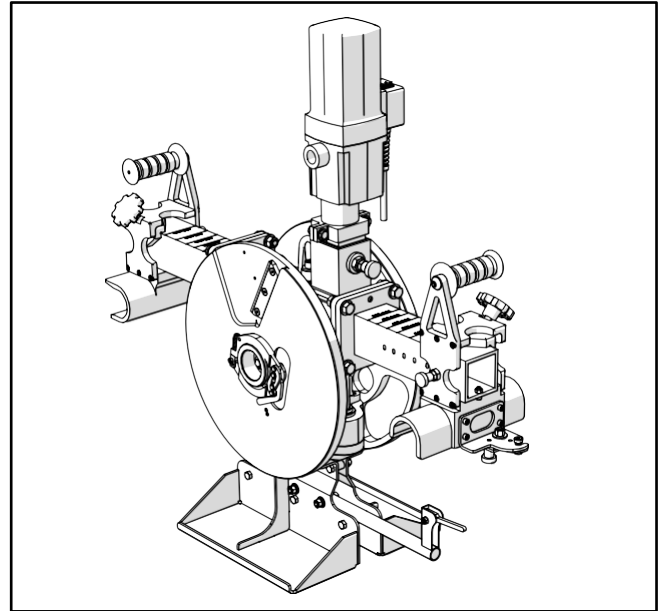

CD02246-6-14-18

- 3) Ensure the drive motor is set to lowest speed. The drive motor should be set to 110 min<sup>-1</sup>. There are two switches on the motor that set speed. Push power cord side switch toward facer drive unit and push the opposite side switch away from facer drive unit.

**NOTICE:** Operating motor in high gear will damage motor.

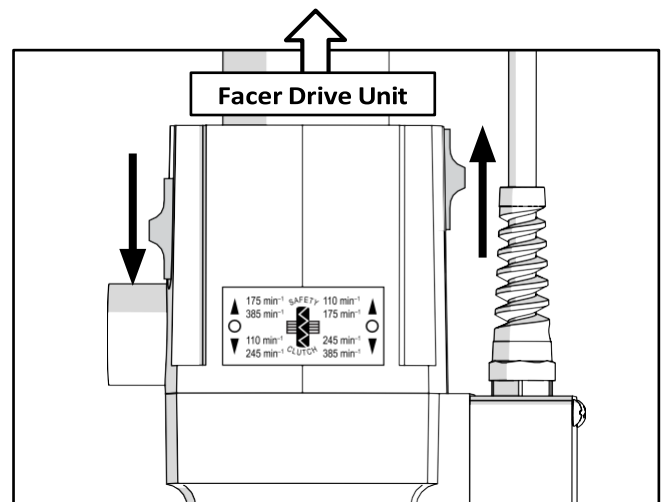

CD02251-6-14-18

## Lift Equipment

### Lift QuikFit™ Carriage:

- 1) There are 6 lifting points (A) on carriage. Use at least 2 lift points when lifting carriage. Lift carriage in an orientation that is required by fusion position.

**NOTICE:** Use lift points for lifting carriage only. Do not use lifting points to lift carriage with pipe. Support the pipe by other means. Lifting other objects with carriage could cause lift points to fail, damaging carriage.

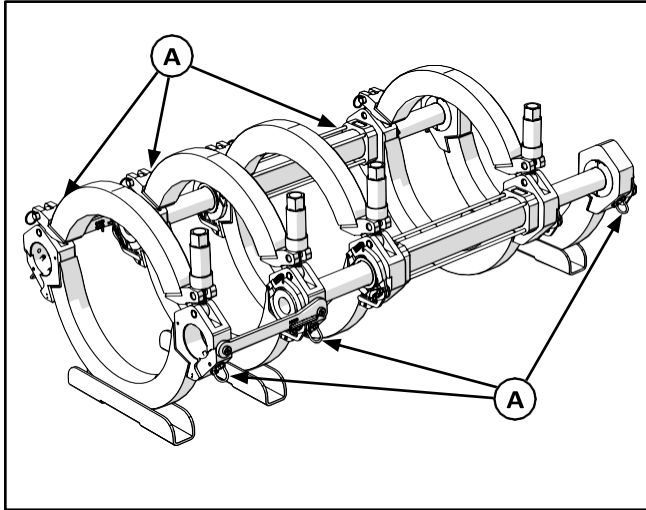

CD02247-6-14-18

### Lift Facer Drive Unit:

- 1) There is a single lift point on facer drive unit. Attach a sling at lift point (B) to lift facer.

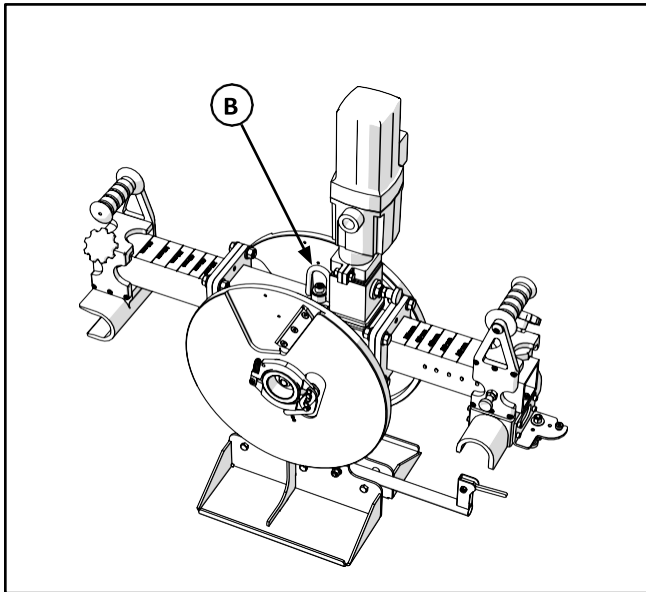

CD02248-6-14-18

### Lift Hydraulic Power Unit (HPU):

- 1) There are 4 lifting points (C) on HPU. Attach a lifting sling to all 4 lifting points to lift HPU.

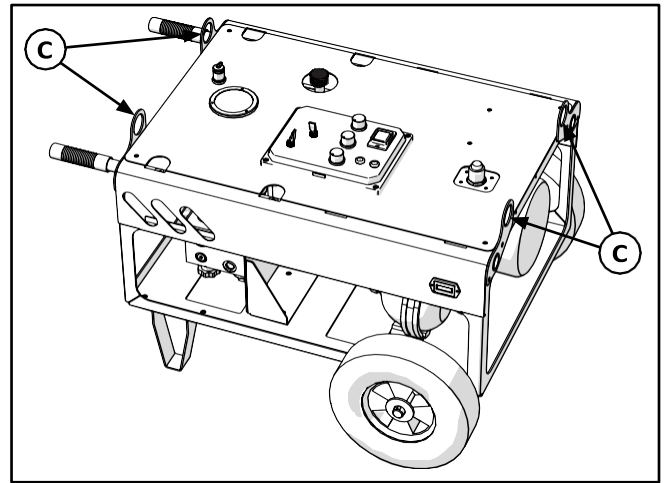

CD02216-5-14-18

TX05340-06-18

# OPERATION - BUTT FUSION

## Check Fluid Level

- 1) Before connecting to power and with HPU off, unscrew dipstick (A). The fluid level should be between the HIGH mark and bottom of dipstick while HPU is on a level surface.

**IMPORTANT:** Ensure HPU is on a level surface. Unscrew the dipstick and wipe clean with a lint-free cloth. Screw dipstick in completely then remove to check fluid level

Refer to [Hydraulic Fluids](#) section of this manual for hydraulic fluid recommendations.

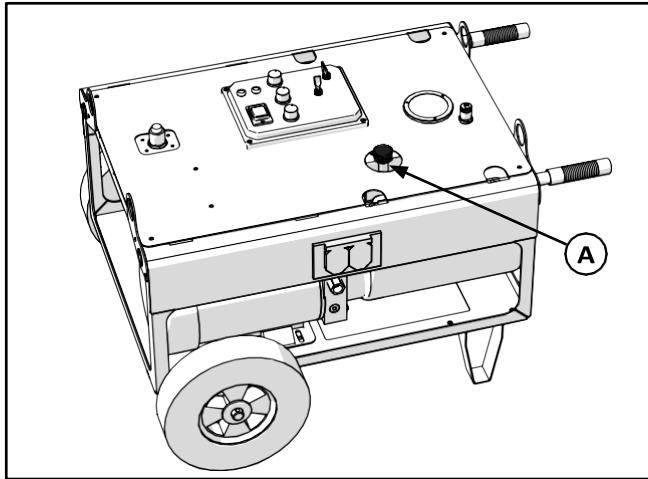

CD02217-5-14-18

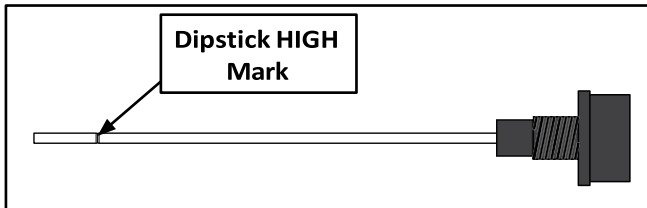

CD02249-5-14-18

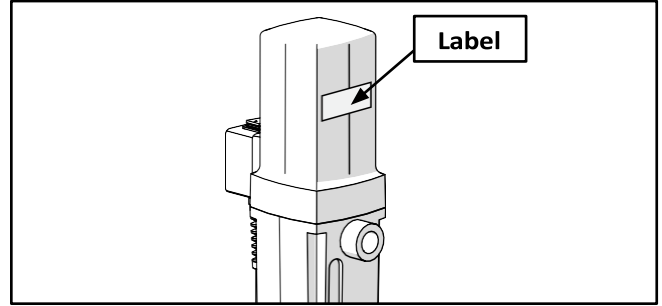

CD02250-5-14-18

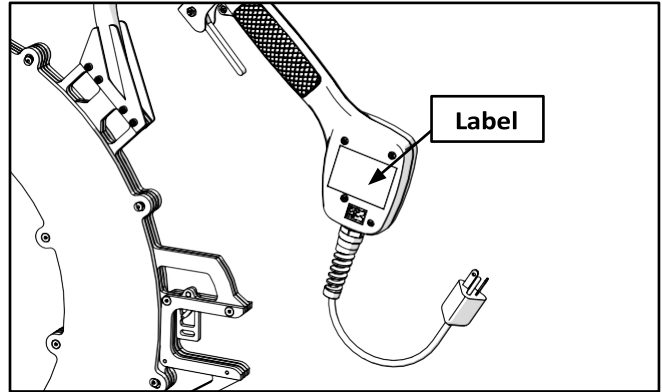

CD02208-5-23-18

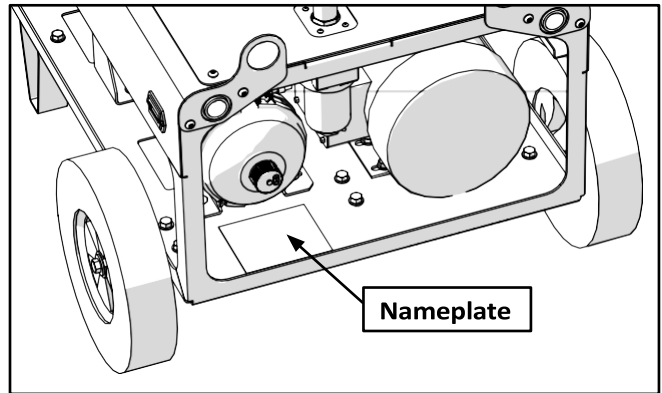

CD02252-5-23-18

## Connecting to Power

**⚠ DANGER**

All electrical equipment and power sources must be located in a non-explosive atmosphere. Failure to do so will result in serious injury or death.

Each device must be connected to a source rated for each device's power requirements. Each device has a plate or label with device's power requirements.

Consult generator sizing form in the back of this manual to determine the proper size generator to power all electrical equipment.

The heater and facer drive unit plugs into electrical outlets on HPU (B). The left receptacle is for facer drive unit and right receptacle is for heater.

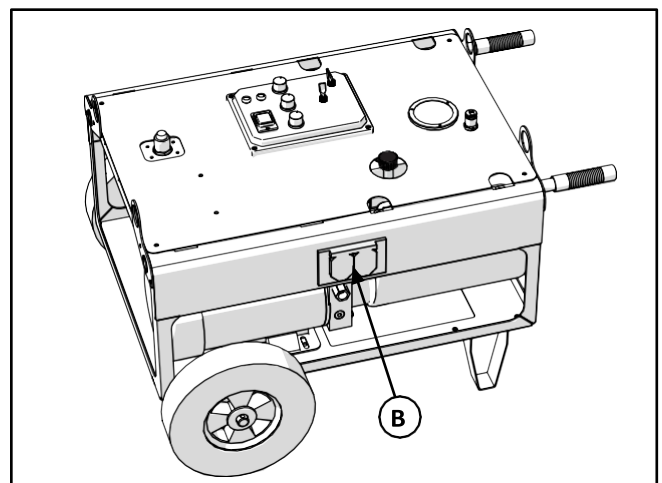

CD02217-5-14-18

# Prepare Heater

**DANGER**

This heater is not explosion proof. Operation of heater in an explosive atmosphere without necessary safety precautions will result in serious injury or death.

When operating in an explosive atmosphere, the heater should be brought up to temperature in a safe environment, then unplugged before entering the explosive atmosphere for fusion.

- 1) Ensure heater is cool. Install butt fusion heater plates.

**NOTICE:** The heater should never be used without butt fusion heater plates installed. Refer to the [“Changing Heater Plates/Adapters”](#) section of this manual for installation procedure.

**CAUTION**

The heater is hot and will burn clothing and skin. Keep the heater in its insulated heater stand or blanket when not in use, and use care when heating the pipe.

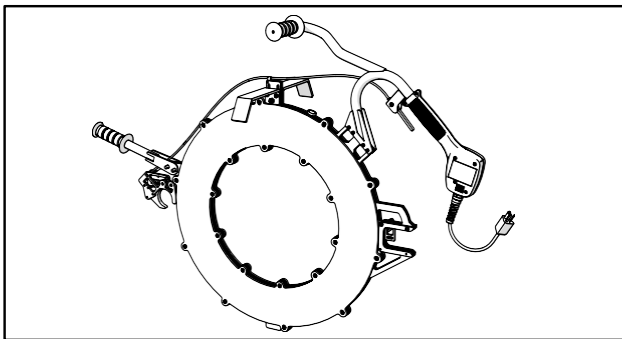

CD02208-6-14-18

- 2) Place heater in insulated heater stand.
- 3) Rotate guide rod adjustment block down for use with larger size carriage, rotate up for smaller size carriage.

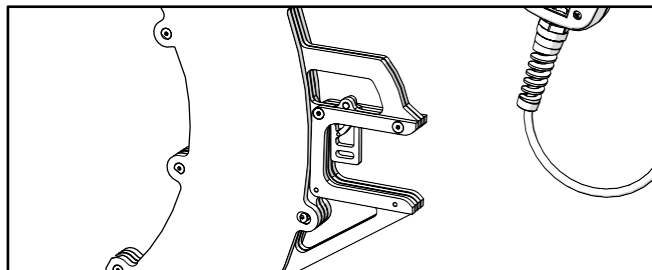

CD02208-6-14-18

- 4) Remove pin (A) above guide rod latch to adjust heater guide rod spacing. Position latch inward (B) for small carriage size and outward (C) for larger carriage size. Insert pin into aligned holes.
- 5) Plug heater into right electrical receptacle on HPU.

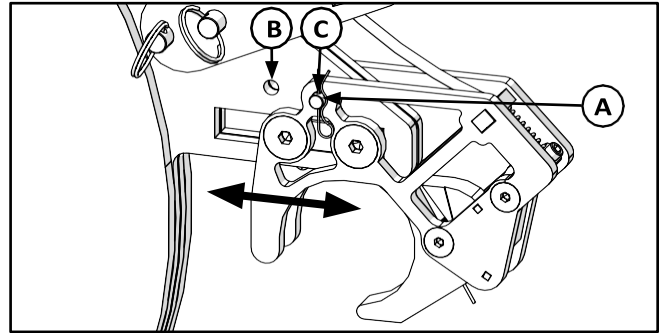

CD02276-6-14-18

## Adjusting Heater Temperature:

- 6) Turn knob to desired temperature. Allow heater to reach temperature. Measure the heater surface temperature with a pyrometer. Any variance must be corrected to the pyrometer reading.

Loosen set screw in the knob. Turn knob to point to the temperature of the pyrometer reading. Tighten set screw in the knob.

Turn knob to desired temperature. Allow heater to stabilize at the new temperature (5 to 10 minutes) after adjusting.

The thermometer on the heater body indicates internal temperature and should be used as a reference only.

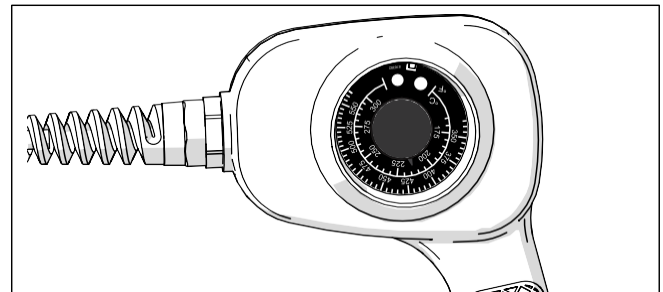

CD02152-2-21-18

The heater has a green indicator light which will flash on and off. This indicates that the controller is operating normally. If the green indicator is not flashing then the controller may not be operating properly. If this occurs, disconnect power and have the heater repaired by a McElroy Authorized Service Center.

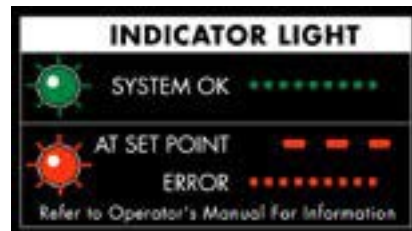

PH02571-2-21-18

The heater has a red indicator light on the handle at the bottom of the temperature scale. When the heater is plugged in and preheating the red light glows steadily until the set temperature is reached. The red light then goes off and on as the heater maintains temperature.

If the heater is not operating properly, the control will attempt to turn the heater off and the red indicator light will flash rapidly. If this occurs, disconnect the power and take it to a McElroy Authorized Service Center for repair.

- 7) Allow heater to warm-up to operating temperature.

## Hydraulic Power Unit

**⚠ DANGER**

All electrical equipment and power sources must be located in a non-explosive atmosphere. Failure to do so will result in serious injury or death.

Locate HPU in a safe environment. Plug the electrical cord into a proper power source.

- 1) Turn on main power switch (A).

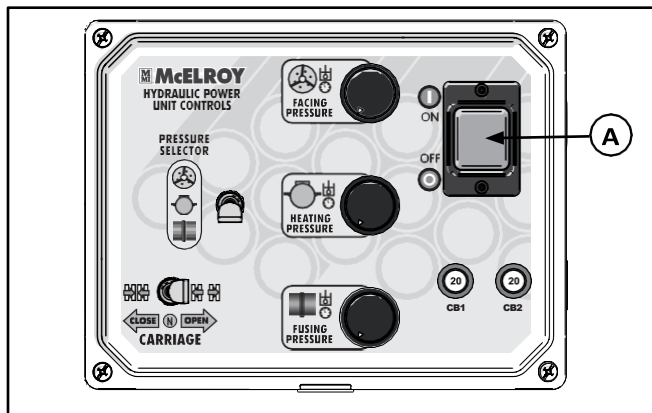

CD02218-5-14-18

## Connect HPU to QuikFit™ Carriage

- 1) With HPU on, adjust pressure to its minimum setting. Actuate carriage switch to relieve pressure in carriage hoses, then turn HPU off.
- 2) Remove dust caps for hydraulic cylinder and HPU hoses.
- 3) Screw female quick disconnect onto male quick disconnect. Screw connectors together until yellow o-ring (D) is not visible.

**⚠ WARNING**

Escaping fluid under pressure can penetrate the skin causing serious injury. Keep hands and body away from pinholes which eject fluid under pressure. Use a piece of cardboard or paper to search for leaks. If any fluid is injected into the skin, it must be immediately removed by a doctor familiar with this type of injury.

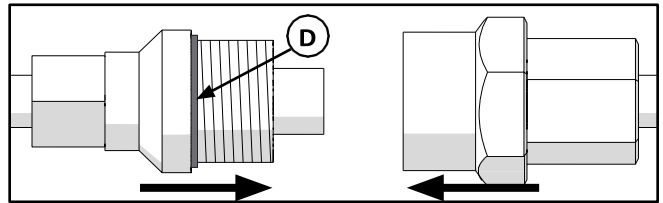

CD02253-5-23-18

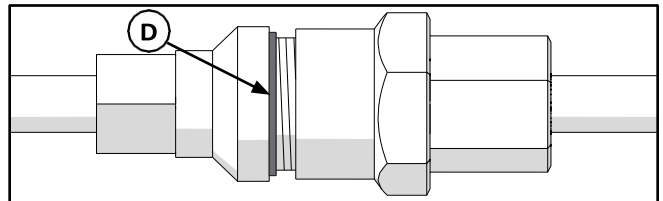

CD02254-5-23-18

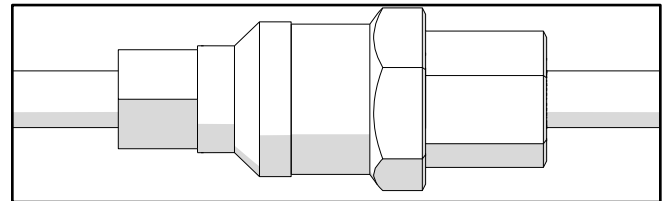

CD02255-5-23-18

## Prepare Facer

**⚠ DANGER**

Electric motors are not explosion proof. Operation of these components in an explosive atmosphere without necessary safety precautions will result in serious injury or death.

- 1) Assemble facer drive unit, refer to [Assemble Facer Drive Unit](#) for information on assembly instructions.
- 2) Ensure facer drive unit power switch is in off position.
- 3) Inspect the facer blades on the blade holder for damage or dullness. Replace damaged or dull blades. Refer to "[Facer Blades](#)" in the Maintenance section for information about facer blades.
- 4) Plug facer into left electrical receptacle on HPU.

**IMPORTANT:** When the facer is on, the heater receptacle will be disabled.

## ⚠ WARNING

Facer blades are sharp and can cut. Never attempt to remove shavings while the facer is running, or is in the facing position between the jaws. Use care when operating the facer, and when handling the unit.

**NOTICE:** Never extend the facer blades beyond the inner or outer circumference of the facer.

The facer blades can be mounted in two positions: one will expel pipe material out of the pipe and the second will push pipe material inside the pipe.

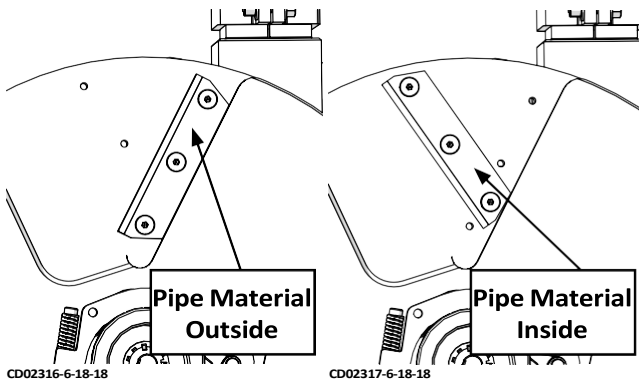

## Hydraulic Pressure

The pressure gauge indicates the pressure at the carriage directional control. The pressure shown on the gauge is determined by the position of the pressure selector and the pressure setting of the selected pressure reducing knobs.

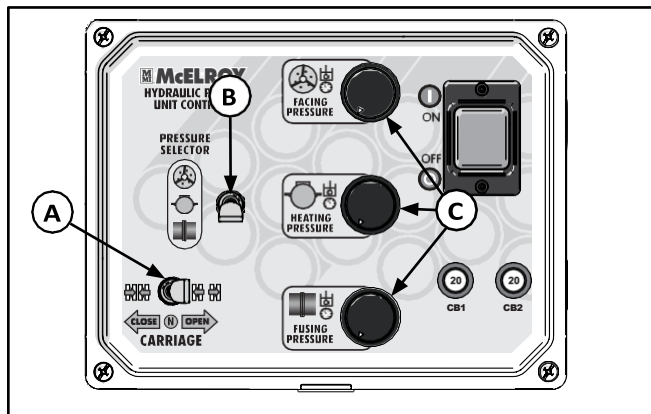

- A - Carriage Directional Control
- B - Pressure Selector Control
- C - Pressure Reducing Knobs (3)
- D - Carriage Pressure Gauge

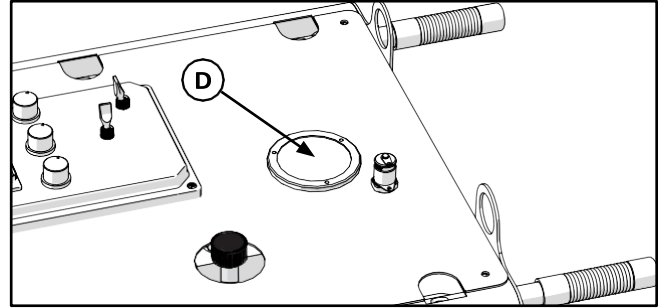

## Support Pipe

### ⚠ WARNING

The Acrobat carriage is not designed to support overhead or overhung loads. Adequately support the pipe using appropriate support devices. If not supported, overhead loads could fall causing serious injury or death.

Ensure the pipe is properly supported before attaching the carriage to the pipe. Ensure there is enough travel in the pipe to complete the fusion.

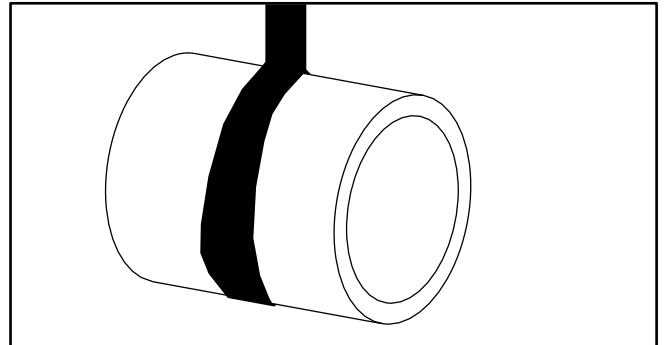

## Loading Pipe

Clean the inside and outside of pipe ends that are to be fused.

Open the upper jaws and insert pipe in each pair of jaws. Let the ends of the pipe protrude past the face of the jaws at least 1" (25mm) on fixed jaw side and 1.25" (32mm) on movable jaw side. Any additional amount of pipe protruding will be amount of pipe material to be removed.



Insert the facer drive unit into place. With the carriage directional control, move the carriage toward the fixed jaws while watching the gap at each end of the facer stops. When the pipe is in contact with the facer, this gap indicates the amount of material that will be trimmed from the pipe end. Assure sufficient material will be removed for a complete face off.

**NOTICE:** Use a low pressure setting to avoid damaging the facer.

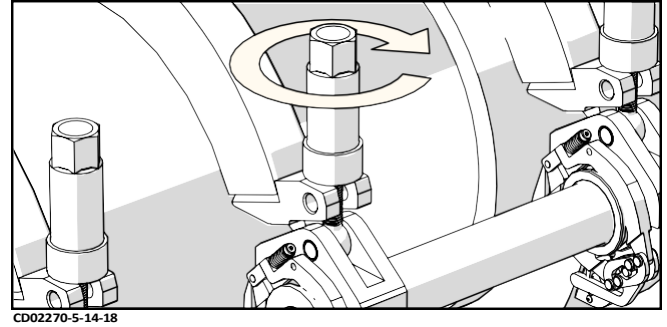
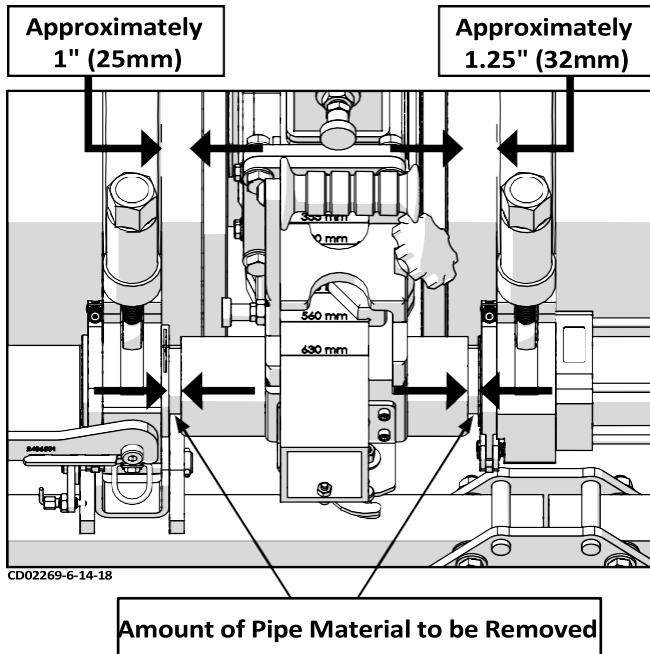

## Facing the Pipe

- 1) Open carriage and install the facer drive unit, ensuring facer rests on carriage guide rod. Rotate guide rod latch to lock facer drive unit to guide rod.

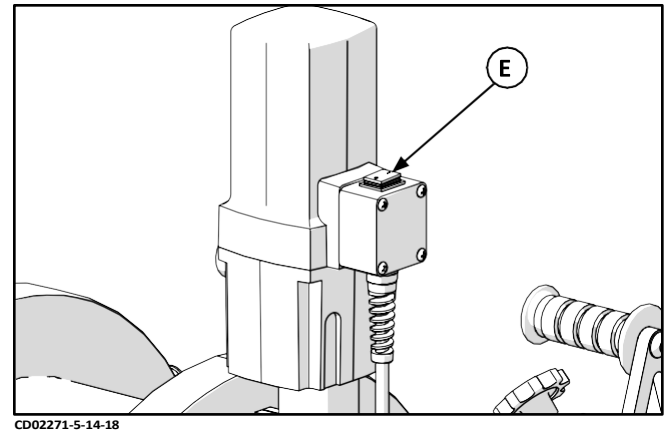

- 2) Turn on the facer drive unit (E).

Ensure the pressure selector control is in the facing position.

- 3) Close the carriage.

If the facer stalls, reduce the facing pressure so the facer continues to cut.

- 4) Continue facing until both jaws contact the facer stops on both sides.
- 5) Switch the carriage directional control to the neutral position.

Allow the facer to run for several revolutions to ensure that there are no chips hanging on the end of the pipe.

- 6) Turn facer off.

## Clamp the Pipe

- 1) Tighten the clamp knobs on the outside jaws to prevent pipe from slipping. Hand tighten the inside clamp knobs to allow for HI/LO adjustment.
- 2) The clamp knobs are equipped with a ball thrust bearing, which permit the operator to develop high clamp forces with minimal effort.

**NOTICE:** When clamping, do not over-tighten the clamp knobs because machine damage can result. Check to see if there is space between the upper and lower jaws. If the two jaws are touching, do not continue to tighten.

Ensure the facer has come to a complete stop.

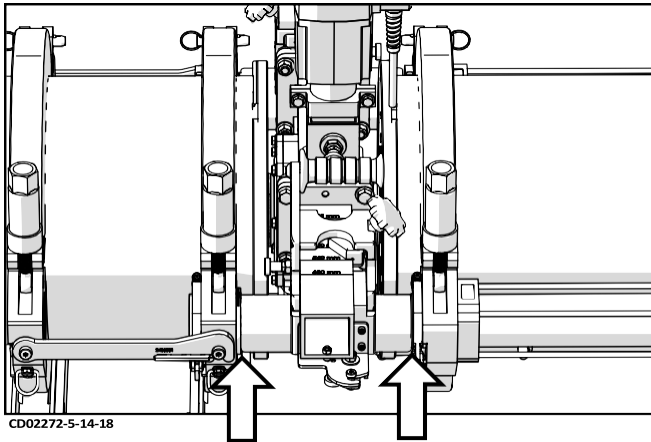

- 7) Move the carriage directional control to the right to open the carriage.
- 8) Turn off the HPU.
- 9) Rotate and release guide rod latch, and lift the facer drive unit out.
- 10) Remove chips from pipe ends.

Do not touch faced pipe ends.

- 11) Inspect both pipe ends for complete face off. If the face off is incomplete, return to [Loading Pipe](#).

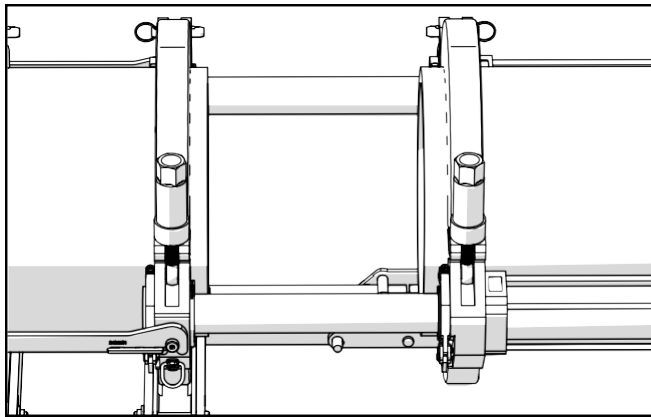

- 12) Turn on the HPU.

## Check Alignment

- 1) Close the carriage until the ends of the pipe butt together.
- 2) Check pipes for alignment.

### ⚠ WARNING

Do not use finger to check for HI/LO (misalignment). The unit is under pressure, and slippage could result in crushed fingers. Always keep hands clear of the jaw area.

If pipe is not lined up, tighten the high side jaw to bring into alignment. Refer to pipe manufacturer's recommendations or appropriate joining standard for proper alignment. Reinsert the facer and reface the pipe.

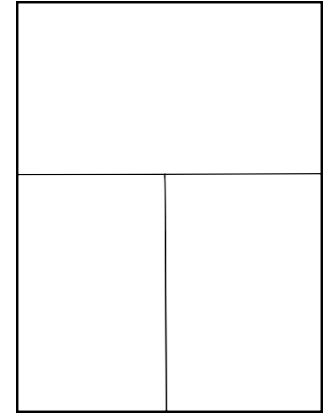
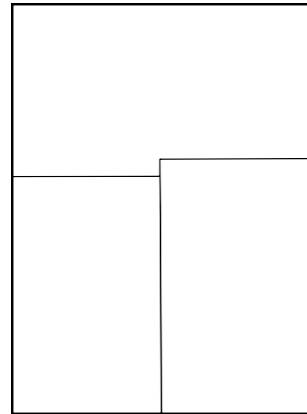

**IMPORTANT:** Always tighten the side that is higher, never loosen the low side.

When the pipe is properly aligned tighten outside clamps to insure against slippage.

**NOTICE:** When clamping, do not over-tighten the clamp knobs because machine damage can result. Check to see if there is space between the upper and lower jaws. If the two jaws are touching, do not continue to tighten.

Ensure there is no unacceptable gap between the pipe ends. If there is unacceptable gap, reinsert facer and reface.

- 3) Close the carriage and check for slippage. Apply fusion pressure and inspect if the pipes slip. If slippage occurs, return to [Loading Pipe](#).

## Determine Drag Pressure

- 1) Move the carriage so that the faced pipe ends are approximately 1" (25.4mm) apart.
- 2) Shift the carriage directional control to the middle (neutral) position (A).
- 3) Shift the pressure selector control (B) to the middle heating position, and adjust the heating pressure reducing knob (C) to its lowest pressure by turning the knob counterclockwise completely.
- 4) Shift the carriage directional control to the left (A).
- 5) Gradually increase the heating pressure by turning the knob clockwise slowly. Increase the pressure until the carriage just begins to move.

- 6) Quickly reduce the heating pressure knob counterclockwise until the carriage is just barely moving.
- 7) View pressure on carriage pressure gauge (D). Record this actual drag pressure.

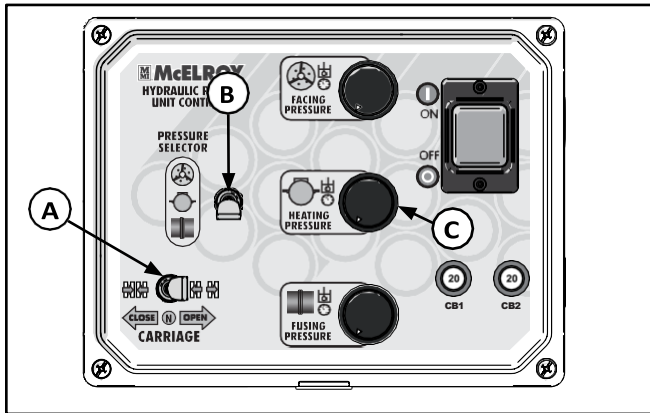

CD02218-5-14-18

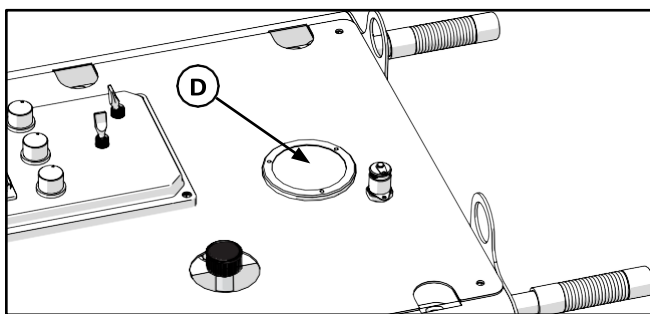

CD02217-5-14-18

## Calculate Fusion Pressure

Using the McCalc app or DataLogger®;  
For Single Wall piping;

- 1) Select Tool
- 2) Select Specification
  - a) DVS 2207-I PE-HD:2005-09 for PE100
  - b) DVS 2207-II PP:2017 for PP
  - c) For PVDF and ECTFE see printed parameters until McCalc is loaded
- 3) Enter pipe OD in MM, select MM for units
- 4) Enter numerical SDR in wall thickness line, select DR/SDR, or numerical wall thickness in mm, and select MM.
- 5) Measure drag pressure as stated above
- 6) McCalc App will add drag pressure to required Bead-up, and Fuse/Cool pressure, and show drag pressure for Heat soak

For Double Contained Piping;

- 1) Refer to printed parameters, (McCalc will eventually be loaded with A/A DC parameters by product line).

## Insert Heater

**NOTICE:** Incorrect heating temperature can result in questionable fusion joints. Check heater plates periodically with a pyrometer and make necessary adjustments.

Refer to [“Prepare Heater”](#) section for how to adjust heater temperature.

- 1) Check heater surface temperature with a pyrometer.

Refer to the pipe manufacturer’s recommendations or appropriate joining standard for proper heater temperature.

**IMPORTANT:** The dial thermometer on the heater indicates internal temperature which varies from the actual surface temperature.

The dial thermometer can be used as reference once the surface temperature has been verified and is never a substitute for actual surface temperature.

**⚠ DANGER**

**This heater is not explosion proof. Operation of heater in an explosive atmosphere without necessary safety precautions will result in serious injury or death.**

- 2) Use a clean dry lint free non-synthetic cloth to clean the butt fusion heater plates.

**⚠ CAUTION**

**The heater is hot and will burn clothing and skin. Keep the heater in its insulated heater stand or blanket when not in use, and use care when heating the pipe.**

- 1) Open the carriage until there is a gap large enough to insert the heater.

**NOTICE:** Do not open a gap too large as this could damage the heater stripper bar.

- 2) Insert heater between pipe ends.
- 3) Ensure the guide rod latch engages the guide rod.

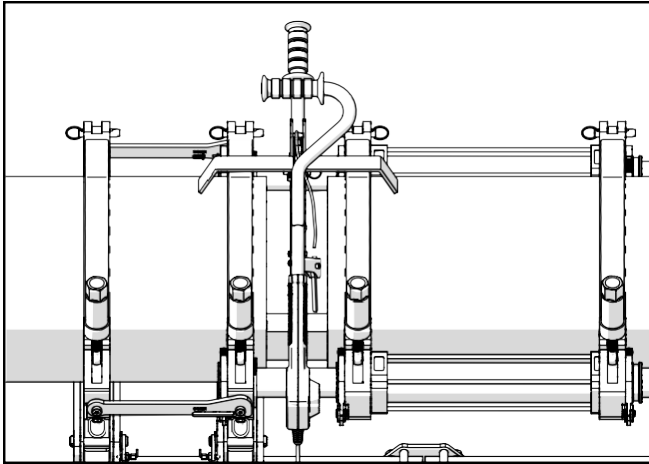

CD02277-5-14-18

## Fusing the Pipe

**NOTICE:** Failure to follow pipe manufacturer's fusion procedures may result in a questionable joint.

After following the pipe manufacturer's suggested heating procedure:

- 1) Shift carriage directional control (A) to neutral position, if it is not already in that position.
- 2) Shift the pressure selector (B) to fusing position.
- 3) Open the carriage (C) just enough to remove the heater.

Quickly remove the heater by grabbing the heater guide rod latch release lever and pulling it into the handle of the heater to release from the guide rod. Inspect pipe ends for appropriate melt.

- 4) Quickly close the carriage (D), bringing the pipe ends together under the pipe manufacturer's recommended pressure.

## Heating the Pipe

- 1) Verify that the pressure selector control (A) is in the fusing position.
- 2) Close carriage (B) to bring pipe ends in contact with the heater.
- 3) Wait for manufacturer's recommended bead up.
- 4) After the proper bead-up, move pressure selector control to middle (heating mode) position (C) and wait for the gauge to drop to drag pressure.
- 5) If heating pressure is not required by pipe manufacturer's recommendation or appropriate joining standard, or opposing forces are not great enough to move the carriage away from the heater, shift the carriage directional control (D) to neutral.

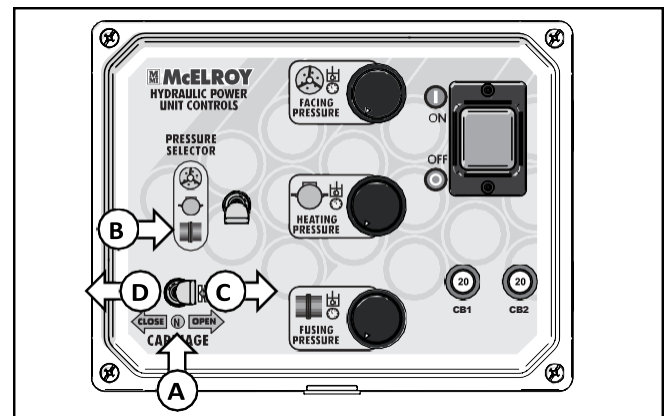

CD02218-5-14-18

Allow joint to cool under pressure according to pipe manufacturer's or appropriate joining standard's recommendations.

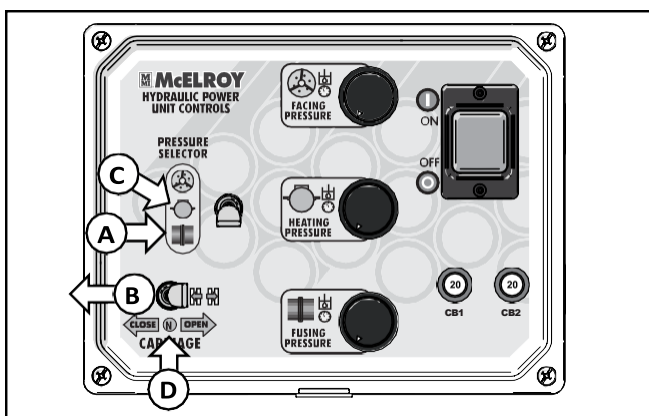

CD02218-5-14-18

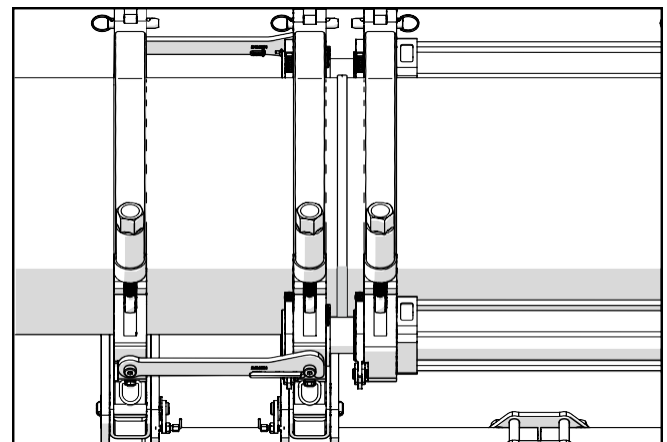

CD02278-5-14-18

---

## Opening Jaws

- 1) After the joint has cooled for the pipe manufacturer's recommended time or appropriate joining standard, shift the carriage directional control to the neutral position.
- 2) Turn off HPU.
- 3) Loosen all clamp knobs. Turn on HPU and open the carriage.
- 4) Open all of the jaws.

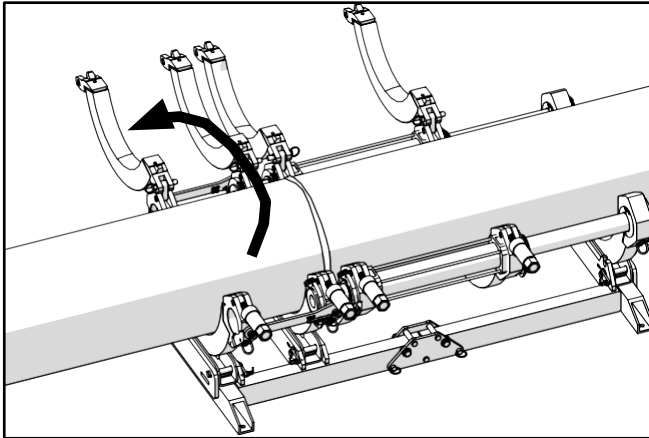

CD02279-5-14-18

## Position Pipe for Next Joint

Move the carriage to end of pipe, or pull the pipe through the jaws. Refer to [Loading Pipe](#) to load pipe and start another fusion.

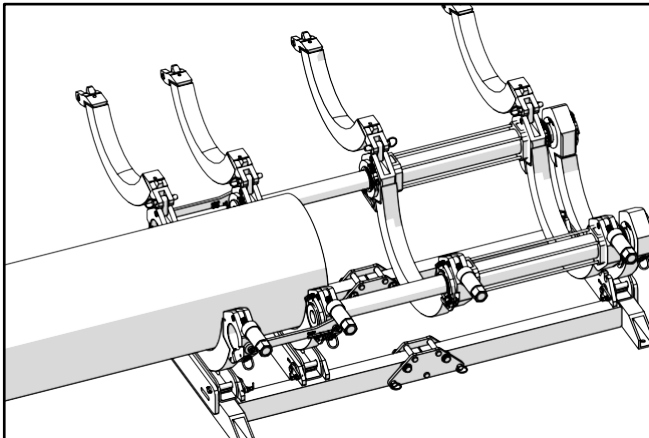

CD02280-5-14-18

# OPERATION - VERTICAL FUSION

## MOVABLE PIPE BELOW

### Vertical Fusion

The Acrobat fusion machines can be used to fuse pipes in a vertical position using the 4-Jaw or 3-Jaw carriage.

The vertical fusion with the movable pipe below is the recommended method for performing vertical fusions.

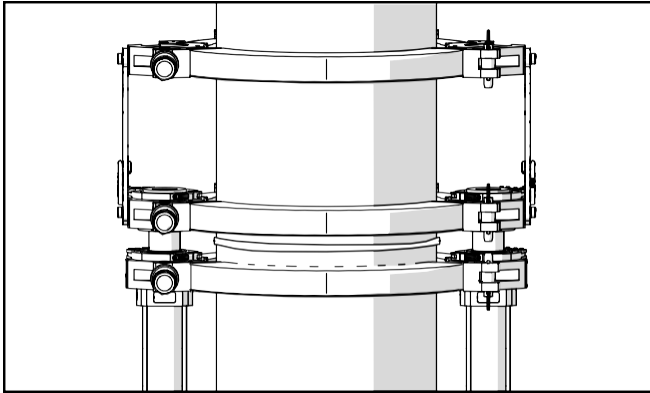

CD02281-6-14-18

**IMPORTANT:** Ensure HPU is on a level surface. Unscrew the dipstick and wipe clean with a lint-free cloth. Screw dipstick in completely then remove to check fluid level

Refer to [Hydraulic Fluids](#) section of this manual for hydraulic fluid recommendations.

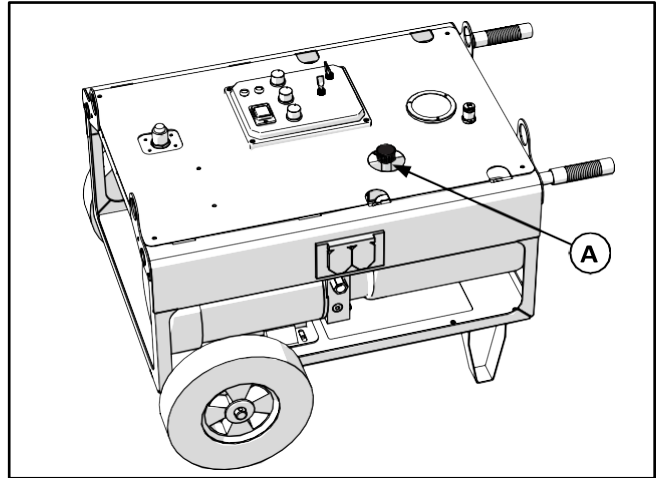

CD02217-5-14-18

### Support Pipe

**WARNING**

The Acrobat carriage is not designed to support overhead or overhung loads. Adequately support the pipe using appropriate support devices. If not supported, overhead loads could fall causing serious injury or death.

Ensure the pipe is properly supported before attaching the carriage to the pipe. Ensure there is enough travel in the pipe to complete the fusion.

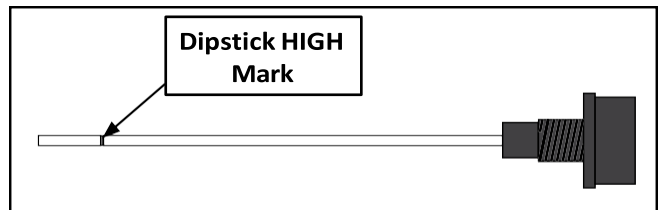

CD02249-5-14-18

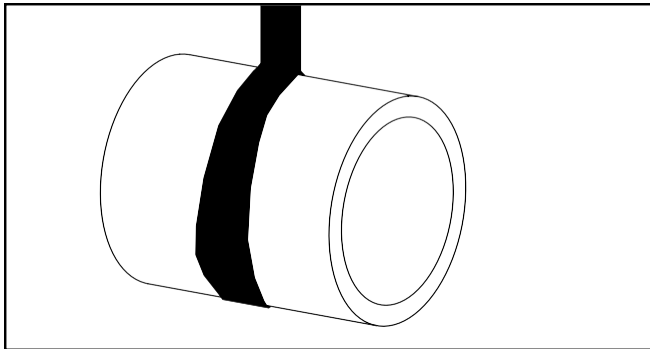

CD01033-6-14-18

### Check Fluid Level

- 1) Before connecting to power and with HPU off, unscrew dipstick (A). The fluid level should be between the HIGH mark and bottom of dipstick while HPU is on a level surface.

## Connecting to Power

**⚠ DANGER**

All electrical equipment and power sources must be located in a non-explosive atmosphere. Failure to do so will result in serious injury or death.

Each device must be connected to a source rated for each device's power requirements. Each device has a plate or label with device's power requirements.

Consult generator sizing form in the back of this manual to determine the proper size generator to power all electrical equipment.

The heater and facer drive unit plugs into electrical outlets on HPU (B). The left receptacle is for facer drive unit and right receptacle is for heater.

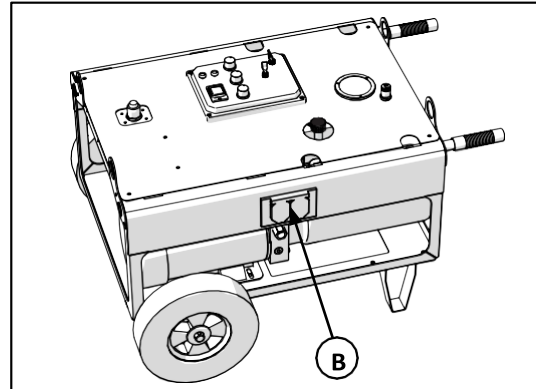

CD02217-5-14-18

## Prepare Heater

**⚠ DANGER**

This heater is not explosion proof. Operation of heater in an explosive atmosphere without necessary safety precautions will result in serious injury or death.

When operating in an explosive atmosphere, the heater should be brought up to temperature in a safe environment, then unplugged before entering the explosive atmosphere for fusion.

- 1) Ensure heater is cool. Install butt fusion heater plates.

**NOTICE:** The heater should never be used without butt fusion heater plates installed. Refer to the [“Changing Heater Plates/Adapters”](#) section of this manual for installation procedure.

**⚠ CAUTION**

The heater is hot and will burn clothing and skin. Keep the heater in its insulated heater stand or blanket when not in use, and use care when heating the pipe.

- 2) Place heater in insulated heater stand.

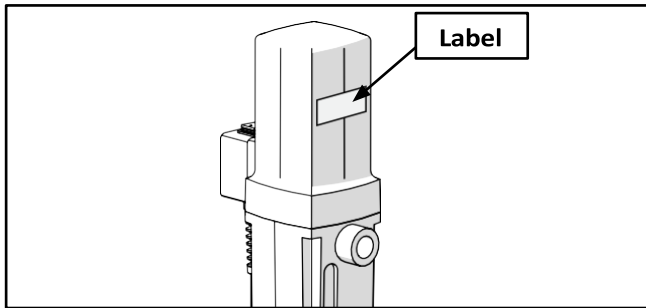

CD02250-5-14-18

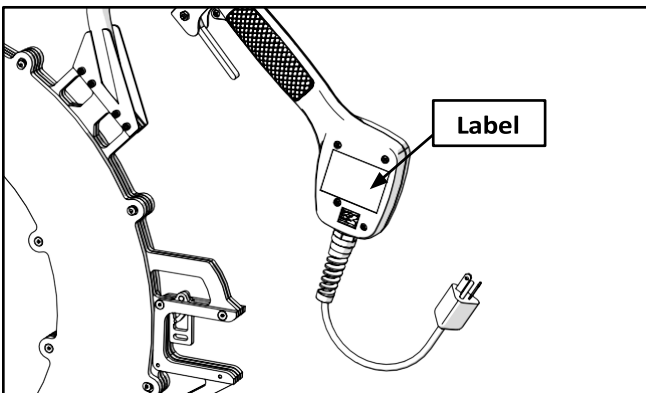

CD02208-5-23-18

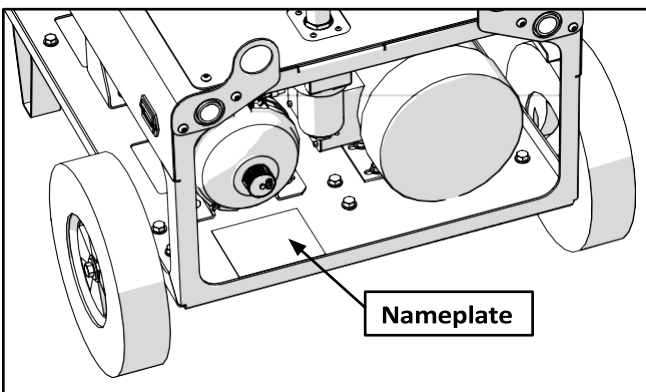

CD02252-5-23-18

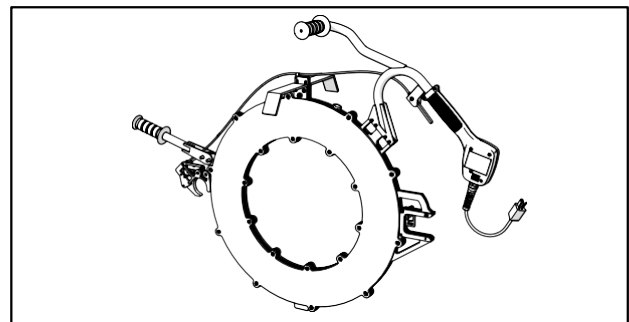

CD02208-6-14-18

- 3) Rotate guide rod adjustment block down for use with larger size carriage, rotate up for smaller size carriage.

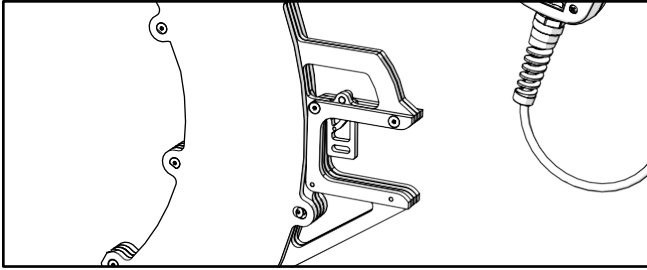

CD02208-6-14-18

- 4) Remove pin (A) above guide rod latch to adjust heater guide rod spacing. Position latch inward (B) for small carriage size and outward (C) for larger carriage size. Insert pin into aligned holes.

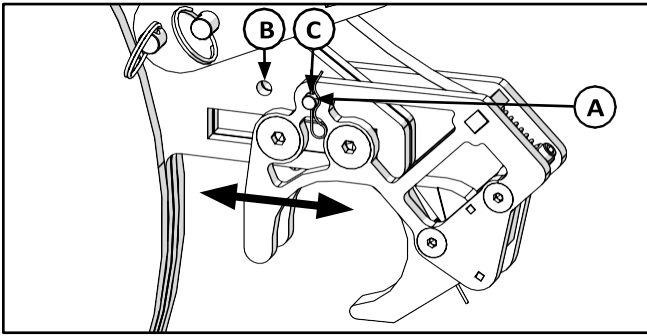

CD02276-6-14-18

- 5) Plug heater into right electrical receptacle on HPU.

### Adjusting Heater Temperature:

- 6) Turn knob to desired temperature. Allow heater to reach temperature. Measure the heater surface temperature with a pyrometer. Any variance must be corrected to the pyrometer reading.

Loosen set screw in the knob. Turn knob to point to the temperature of the pyrometer reading. Tighten set screw in the knob.

Turn knob to desired temperature. Allow heater to stabilize at the new temperature (5 to 10 minutes) after adjusting.

The thermometer on the heater body indicates internal temperature and should be used as a reference only.

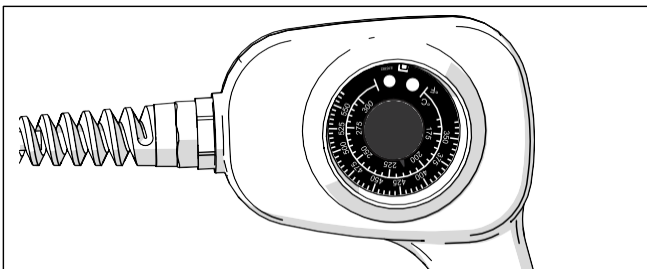

CD02152-2-21-18

The heater has a green indicator light which will flash on and off. This indicates that the controller is operating normally. If the green indicator is not flashing then the controller may not be operating properly. If this occurs, disconnect power and have the heater repaired by an McElroy Authorized Service Center.

The heater has a red indicator light on the handle at the bottom of the temperature scale. When the heater is plugged in and preheating the red light glows steadily until the set temperature is reached. The red light then goes off and on as the heater maintains temperature.

If the heater is not operating properly, the control will attempt to turn the heater off and the red indicator light will flash rapidly. If this occurs, disconnect the power and take it to a McElroy Authorized Service Center for repair.

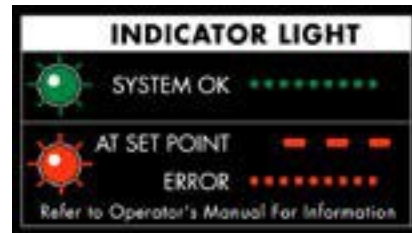

PH02571-2-21-18

- 7) Allow heater to warm-up to operating temperature.

## Hydraulic Power Unit (HPU)

**⚠ DANGER**

All electrical equipment and power sources must be located in a non-explosive atmosphere. Failure to do so will result in serious injury or death.

Locate HPU in a safe environment. Plug the electrical cord into a proper power source.

- 1) Turn on main power switch (A).

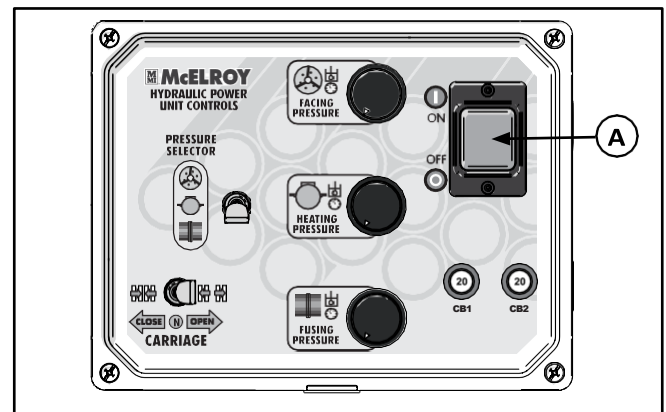

CD02218-5-14-18



## Connect HPU to QuikFit™ Carriage

- 1) With HPU on, adjust pressure to its minimum setting, then turn HPU off.
- 2) Remove dust caps for hydraulic cylinder and HPU hoses.
- 3) Screw female quick disconnect onto male quick disconnect. Screw connectors together until yellow o-ring (D) is not visible.

### ⚠ WARNING

Escaping fluid under pressure can penetrate the skin causing serious injury. Keep hands and body away from pinholes which eject fluid under pressure. Use a piece of cardboard or paper to search for leaks. If any fluid is injected into the skin, it must be immediately removed by a doctor familiar with this type of injury.

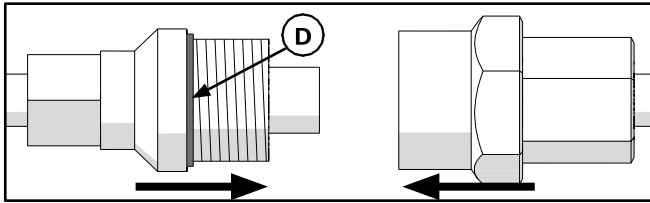

CD02253-5-23-18

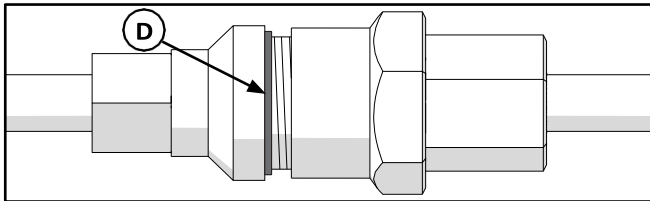

CD02254-5-23-18

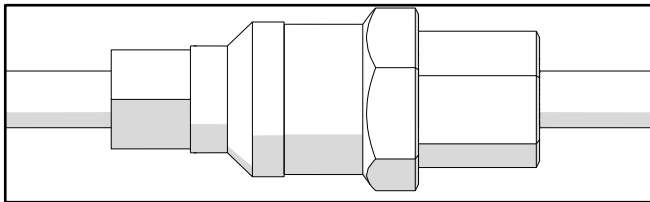

CD02255-5-23-18

## Prepare Facer

### ⚠ DANGER

Electric motors are not explosion proof. Operation of these components in an explosive atmosphere without necessary safety precautions will result in serious injury or death.

- 1) Assemble facer drive unit, refer to [Assemble Facer Drive Unit](#) for information on assembling facer drive unit.
- 2) Ensure facer drive unit power switch is in off position.
- 3) Inspect the facer blades on the blade holder for damage or dullness. Replace damaged or dull blades. Refer to “[Facer Blades](#)” in the Maintenance section for information about facer blades.
- 4) Plug facer into left electrical receptacle on HPU.

**IMPORTANT:** When the facer is on, the heater receptacle will be disabled.

### ⚠ WARNING

Facer blades are sharp and can cut. Never attempt to remove shavings while the facer is running, or is in the facing position between the jaws. Use care when operating the facer, and when handling the unit.

**NOTICE:** Never extend the facer blades beyond the inner or outer circumference of the facer.

The facer blades can be mounted in two positions: one will expel pipe material out of the pipe and the second will push pipe material inside the pipe.

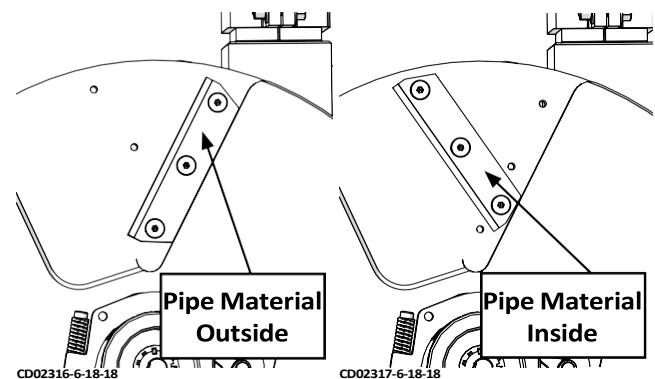

CD02316-6-18-18

CD02317-6-18-18

# Hydraulic Pressure

The pressure gauge indicates the pressure at the carriage directional control. The pressure shown on the gauge is determined by the position of the pressure selector and the pressure setting of the selected pressure reducing knobs.

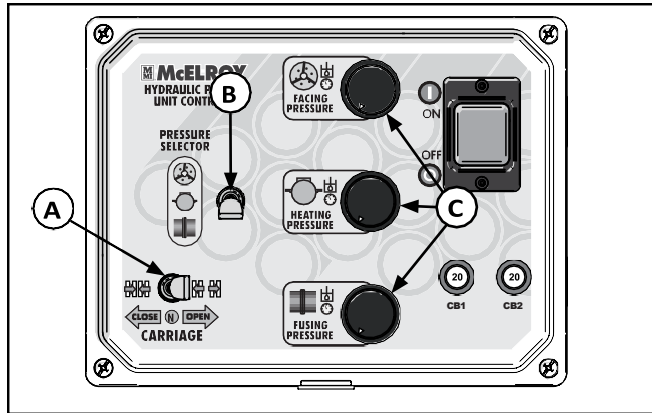

CD02218-5-14-18

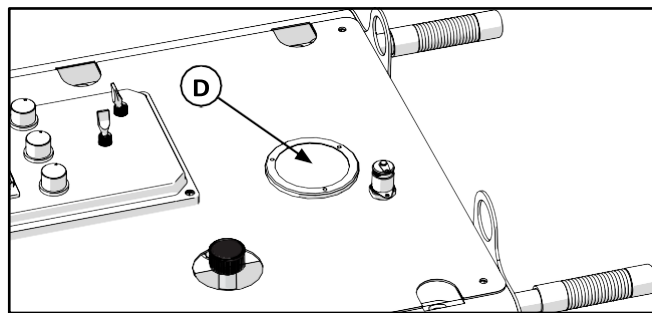

CD02217-5-14-18

- A - Carriage Directional Control
- B - Pressure Selector Control
- C - Pressure Reducing Knobs (3)
- D - Carriage Pressure Gauge

- 2) Relieve pressure in the system. Refer to pipe manufacturer's recommendations or appropriate joining standard for proper alignment. Turn off HPU. Disconnect hoses from the carriage.

**WARNING**

Disconnect carriage from HPU before attaching carriage to pipe. Carriage is operated remotely and remote operation could result in minor to moderate injury.

- 3) Secure carriage and position carriage assembly around the pipes with the fixed jaws positioned around the top pipe. The upper jaws of the carriage can be removed to help with positioning the carriage into position. Once the carriage is around the pipes, reinstall the upper jaws to the carriage.

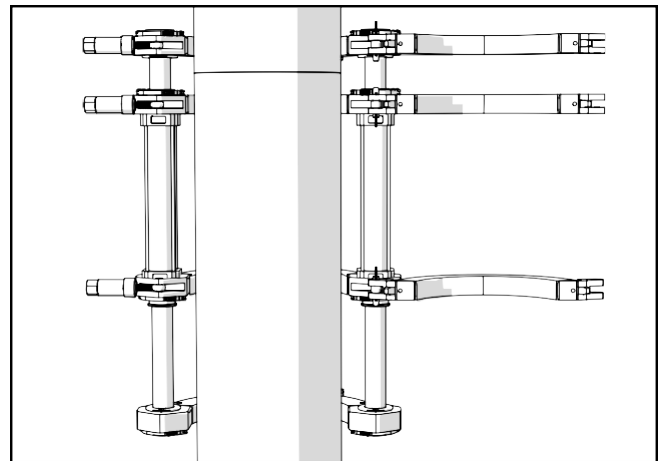

CD02284-6-14-18

The carriage may also be assembled on the pipes piece by piece until the carriage is completely assembled. Refer to [Assemble Carriage](#) for instructions on assembling carriage.

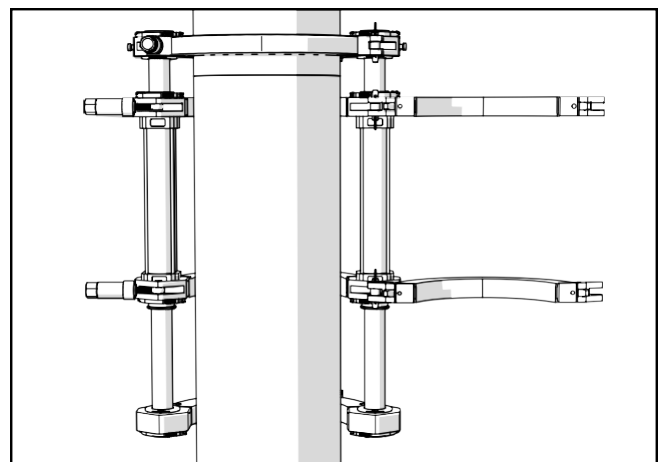

CD02285-6-14-18

## Attach Carriage to Pipe

- 1) Position the pipe to be fused below the fixed pipe.

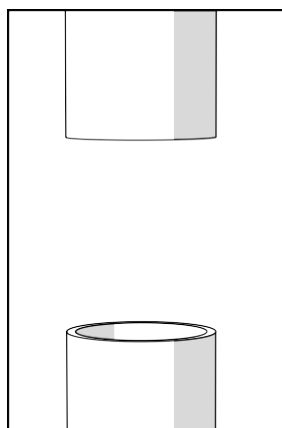

CD02283-6-14-18

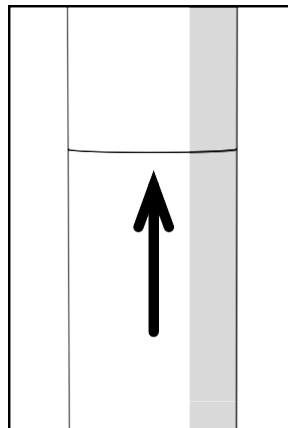

CD02282-6-14-18

- 4) Close the fixed jaws on the pipe. Allow at least 1" (25mm) of pipe protruding from fixed jaws, any additional pipe protruding will be pipe material that will be removed during facing. Tighten the clamp knobs on the fixed jaws.
- 5) With HPU off, connect hydraulic hoses to carriage. Ensure carriage control is in neutral position.
- 6) Turn on HPU.
- 7) Use carriage directional control to slowly close carriage. Allow carriage to close until there is at least 1.25" (32mm) of pipe protruding from the movable jaws, any additional pipe protruding will be pipe material that will be removed during facing.

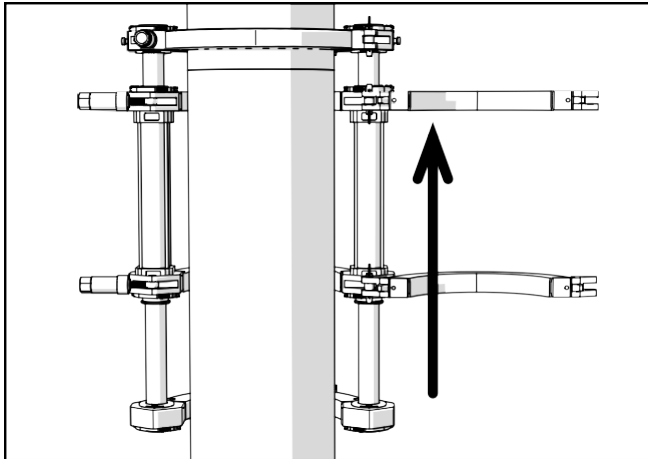

CD02285-5-23-18

- 8) Stop carriage and close movable jaws on pipe. Tighten the clamp knobs on movable jaws.

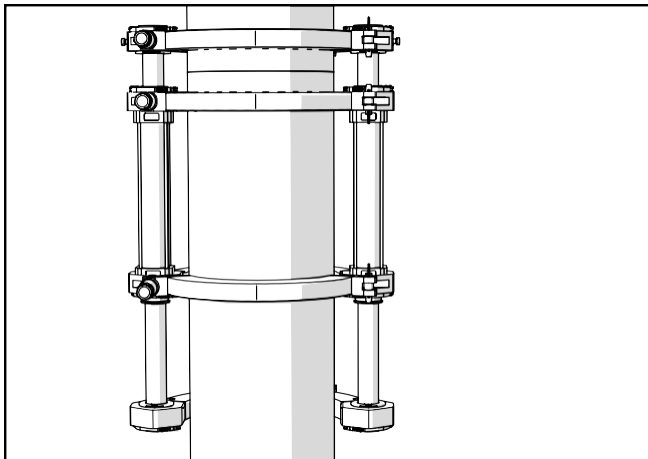

CD02286-5-23-18

- 9) Open carriage

## Facing the Pipe

- 1) Open carriage and install the facer drive unit, ensuring facer rests on carriage guide rod. Rotate guide rod latch to lock facer drive unit to guide rod.

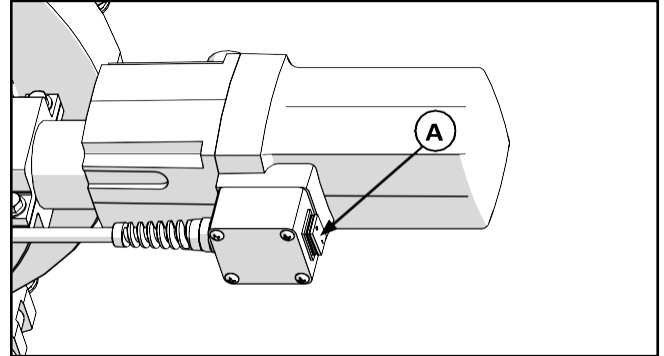

CD02271-5-14-18

- 2) Turn on the facer drive unit (A).

Ensure the pressure selector control is in the facing position.

- 3) Close the carriage.

If the facer stalls, reduce the facing pressure so the facer continues to cut.

- 4) Continue facing until both jaws contact the facer stops on both sides.

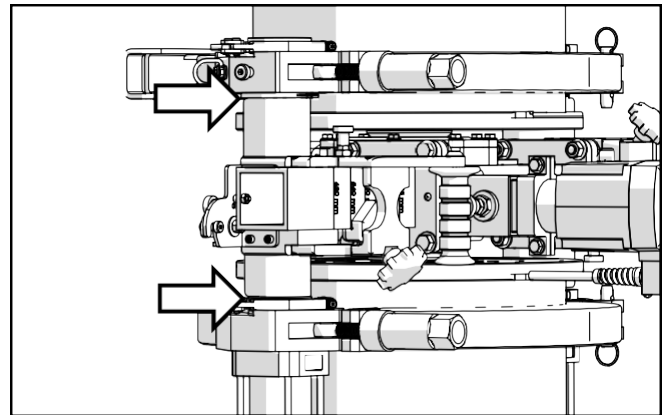

CD02287-5-14-18

- 5) Switch the carriage directional control to the neutral position.

Allow the facer to run for several revolutions to ensure that there are no chips hanging on the end of the pipe.

- 6) Turn facer off.

Ensure the facer has come to a complete stop.

- 7) Move the carriage directional control to the right to open the carriage.
- 8) Turn off the HPU.
- 9) Rotate and release guide rod latch, and lift the facer drive unit out.
- 10) Remove chips from pipe ends.

Do not touch faced pipe ends.

- 11) Inspect both pipe ends for complete face off. If the face off is incomplete, return to Loading Pipe.

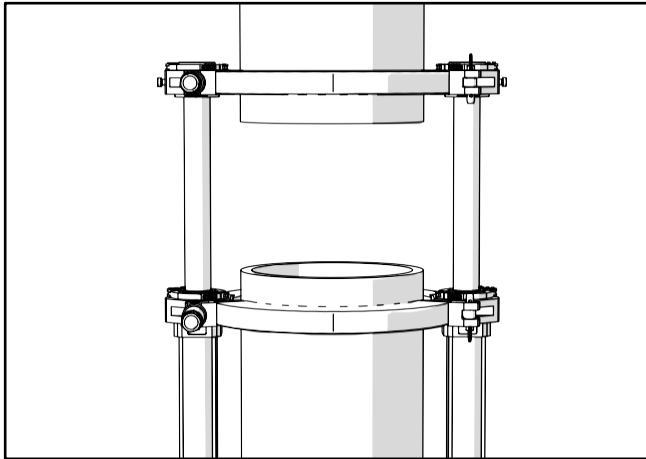

CD02288-5-23-18

- 12) Turn on the HPU.

## Check Alignment

- 1) Close the carriage until the ends of the pipe butt together.
- 2) Check pipes for alignment.

### WARNING

**Do not use finger to check for HI/LO (misalignment). The unit is under pressure, and slippage could result in crushed fingers. Always keep hands clear of the jaw area.**

If pipe is not lined up, tighten the high side jaw to bring into alignment. Refer to pipe manufacturer's recommendations or appropriate joining standard for proper alignment. Reinsert the facer and reface the pipe.

**IMPORTANT:** Always tighten the side that is higher, never loosen the low side.

When the pipe is properly aligned tighten outside clamps to insure against slippage.

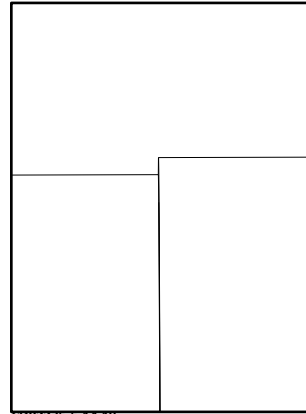

CD02275-5-14-18

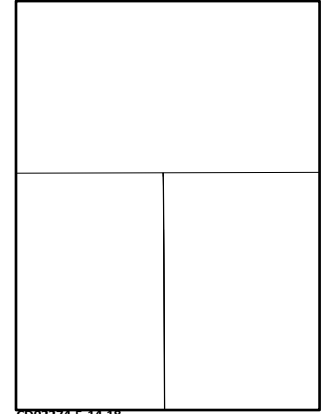

CD02274-5-14-18

**NOTICE:** When clamping, do not over-tighten the clamp knobs because machine damage can result. Check to see if there is space between the upper and lower jaws. If the two jaws are touching, do not continue to tighten.

Ensure there is no unacceptable gap between the pipe ends. If there is unacceptable gap, reinsert facer and reface.

- 3) Close the carriage and check for slippage. Apply fusion pressure and inspect if the pipes slip. If slippage occurs, return to [Attach Carriage to Pipe](#).

## Set Hydraulic Pressures

The weight of the bottom pipe will be pulling down on the carriage. This extra force must be taken into account when setting pressures for vertical fusion.

### Set Heating (Drag) Pressure:

- 1) Open carriage so pipe ends are approximately 2" (50.8mm) apart.
- 2) Shift pressure selector to heating (drag) pressure.
- 3) Turn the heating pressure reducing knob to its lowest setting.
- 4) Move carriage directional control to the close position.
- 5) Turn the pressure reducing knob up until the carriage starts moving then back off until the carriage stops.
- 6) Repeat steps 1-5 to confirm heating (drag) pressure.

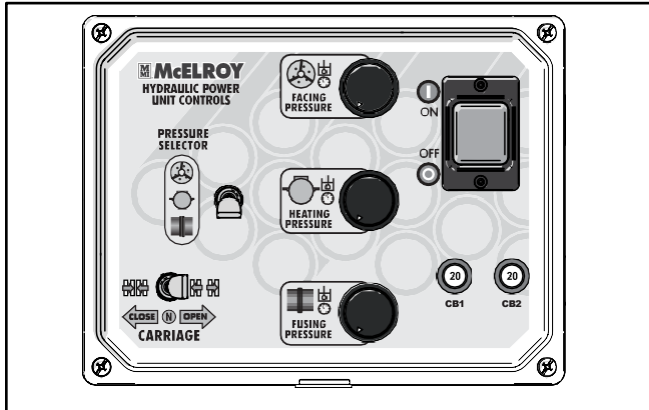

CD02218-5-14-18

The heating pressure will represent the same as drag pressure on a horizontal fusion.

**NOTICE:** Setting the proper heating (drag) pressure will prevent the carriage from moving away or moving toward the fusion joint resulting in an improperly made fusion joint.

**Set Fusing Pressure:** To calculate the vertical fusion pressure, calculate the theoretical fusion pressure and add the heating pressure. The heating pressure must be added or the weight of the pipe will pull the carriage away from the fusion joint.

**Vertical Fusion Pressure = Theoretical Fusion Pressure + Heating (Drag) Pressure**

## Insert Heater

**NOTICE:** Incorrect heating temperature can result in questionable fusion joints. Check heater plates periodically with a pyrometer and make necessary adjustments.

Refer to [“Prepare Heater”](#) section for how to adjust heater temperature.

- 1) Check heater surface temperature with a pyrometer.

Refer to the pipe manufacturer’s recommendations or appropriate joining standard for proper heater temperature.

**IMPORTANT:** The dial thermometer on the heater indicates internal temperature which varies from the actual surface temperature.

The dial thermometer can be used as reference once the surface temperature has been verified and is never a substitute for actual surface temperature.

## **! DANGER**

This heater is not explosion proof. Operation of heater in an explosive atmosphere without necessary safety precautions will result in serious injury or death.

- 2) Use a clean dry lint free non-synthetic cloth to clean the butt fusion heater plates.

## **! CAUTION**

The heater is hot and will burn clothing and skin. Keep the heater in its insulated heater stand or blanket when not in use, and use care when heating the pipe.

- 3) Open the carriage until there is a gap large enough to insert the heater.

**NOTICE:** Do not open a gap too large as this could damage the heater stripper bar.

- 4) Insert heater between pipe ends.
- 5) Ensure the guide rod latch engages the guide rod.

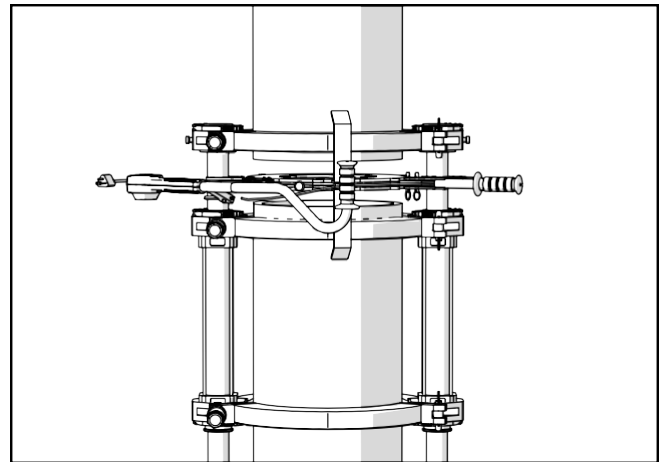

CD02289-5-23-18

## Heating the Pipe

- 1) Verify that the pressure selector control is in the fusing position.
- 2) Close the carriage to bring pipe ends in contact with the heater. Allow for bead-up according to pipe manufacturer's or appropriate joining standard recommendations.

Ensure the heater stays perpendicular to the pipe by supporting the heater during the heating process.

- 3) After proper bead-up, move pressure selector control to middle (heating mode) position and leave the carriage directional control in the closed position.

**NOTICE:** Ensure that the pipe remains in contact with heater throughout the entire process. If the pipe loses contact with the heater, abort the joint and go to ["Attach Carriage to Pipe"](#).

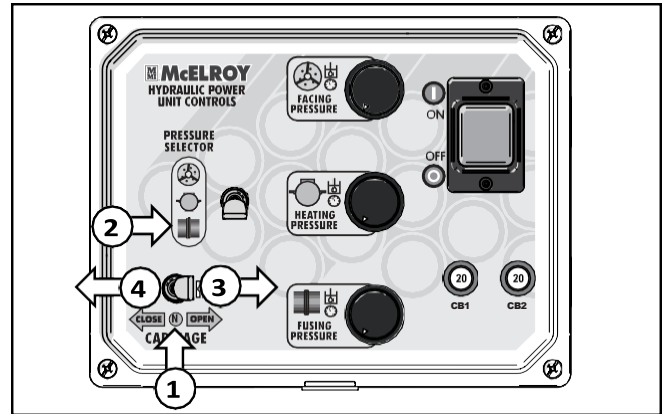
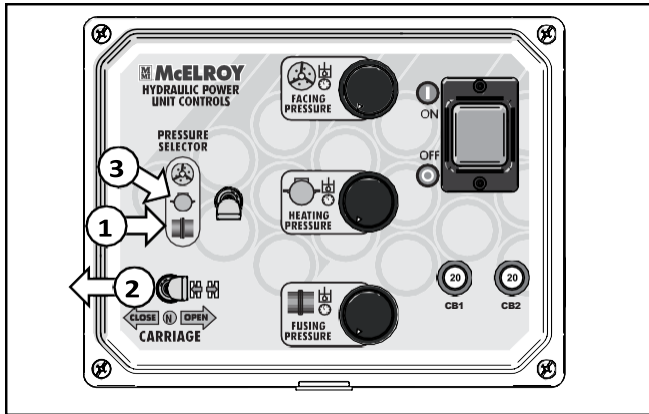

- 4) Quickly close the carriage, bringing the pipe ends together under the vertical fusion pressure.

Allow joint to cool under pressure according to pipe manufacturer's or appropriate joining standard's recommendations.

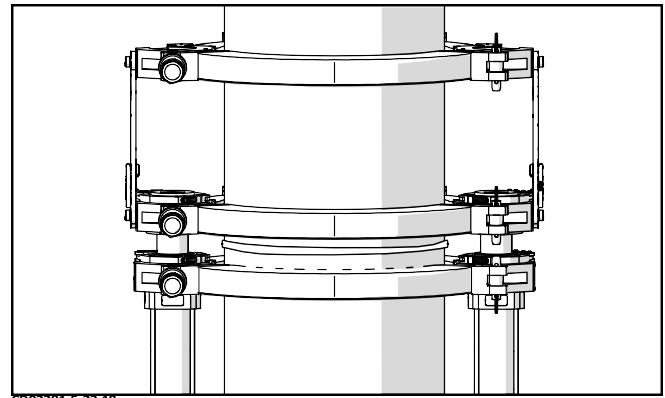
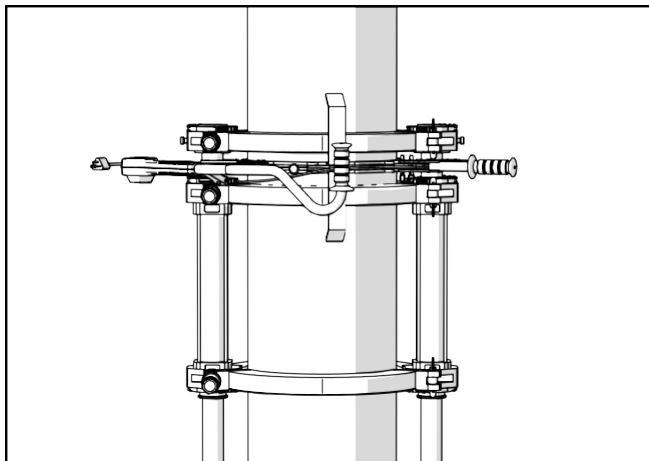

## Fusing the Pipe

**NOTICE:** Failure to follow pipe manufacturer's fusion procedures may result in a questionable joint.

After following the pipe manufacturer's suggested heating procedure:

- 1) Shift carriage directional control to neutral position.
- 2) Shift the pressure selector to fusing position.
- 3) Open the carriage just enough to remove the heater.

Quickly remove the heater by grabbing the heater guide rod latch release lever and pulling it into the handle of the heater to release from the guide rod. Inspect pipe ends for appropriate melt.

---

---

## Opening Jaws

- 1) After the joint has cooled for the pipe manufacturer's or appropriate joining standard recommended time, shift the carriage directional control to the neutral position.
- 2) Relieve hydraulic pressure in the carriage by turning fusing pressure reducing knob to its minimum setting. Actuate carriage switch to relieve pressure in carriage hoses.
- 3) Turn off the HPU.
- 4) Disconnect the hydraulic hoses from the carriage.
- 5) Ensure the pipe is supported before removing the carriage from pipe. Loosen the clamp knobs on movable jaws and open the jaws.

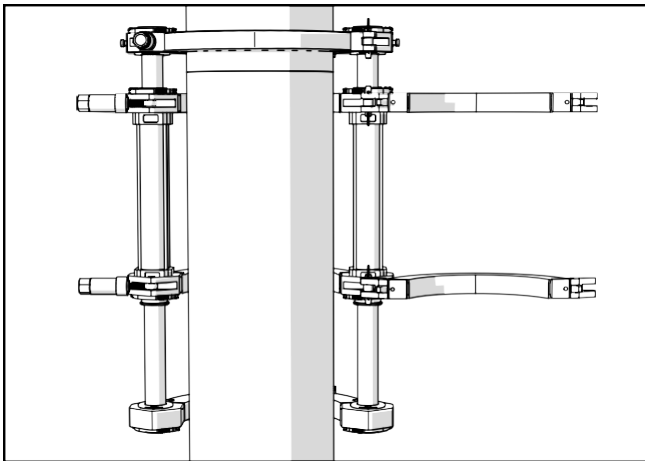

CD02285-5-23-18

- 6) Support the carriage and loosen the clamp knobs on the fixed jaws and open the jaws.

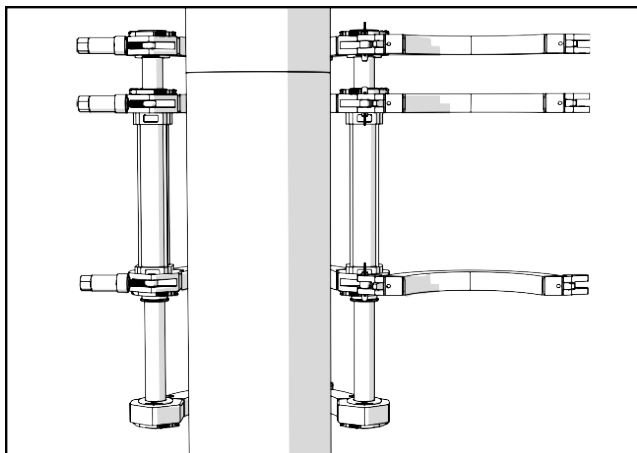

CD02284-5-23-18

- 7) Rotate the carriage out from around the pipe.  
The carriage can also be disassembled piece by piece from the pipe as an alternative method of removal.
- 8) The upper jaws may need to be removed to remove the carriage from the pipe.

TX05369-08-18

# OPERATION - VERTICAL FUSION

## MOVABLE PIPE ABOVE

### Vertical Fusion

The Acrobat fusion machines can be used to fuse pipes in a vertical position using the 4-Jaw or 3-Jaw carriage.

The vertical fusion with the movable pipe below is the recommended method for performing vertical fusions.

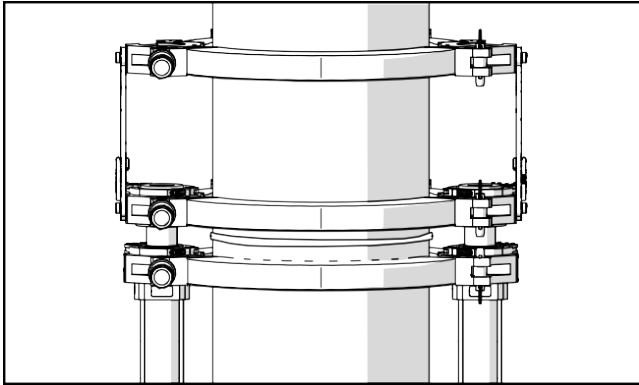

CD02281-5-23-18

**IMPORTANT:** Ensure HPU is on a level surface. Unscrew the dipstick and wipe clean with a lint-free cloth. Screw dipstick in completely then remove to check fluid level

Refer to [Hydraulic Fluids](#) section of this manual for hydraulic fluid recommendations.

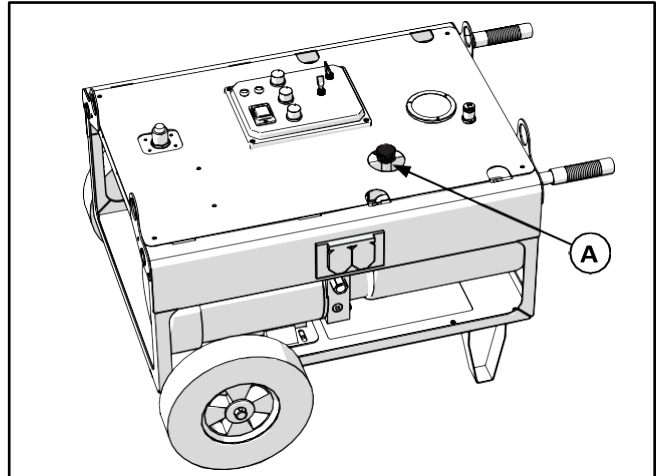

CD02217-5-14-18

### Support Pipe

**WARNING**

The Acrobat carriage is not designed to support overhead or overhung loads. Adequately support the pipe using appropriate support devices. If not supported, overhead loads could fall causing serious injury or death.

Ensure the pipe is properly supported before attaching the carriage to the pipe. Ensure there is enough travel in the pipe to complete the fusion.

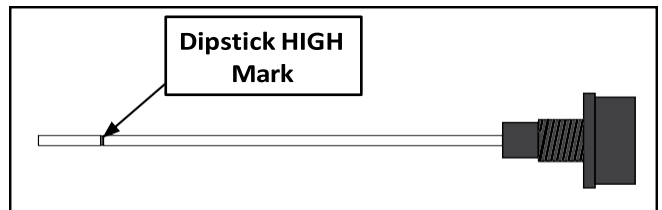

CD02249-5-14-18

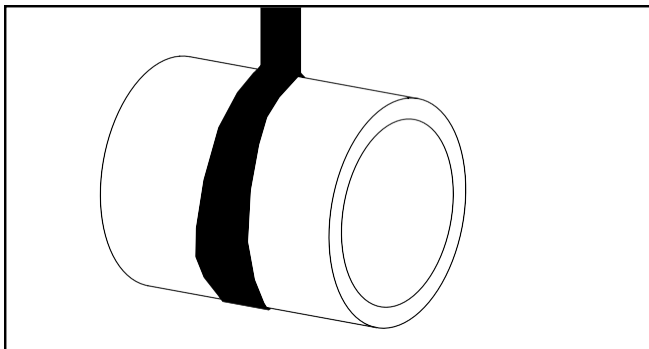

CD01033-5-23-18

### Check Fluid Level

- 1) Before connecting to power and with HPU off, unscrew dipstick (A). The fluid level should be between the HIGH mark and bottom of dipstick while HPU is on a level surface.



## Connecting to Power

**⚠ DANGER**

All electrical equipment and power sources must be located in a non-explosive atmosphere. Failure to do so will result in serious injury or death.

Each device must be connected to a source rated for each device's power requirements. Each device has a plate or label with device's power requirements.

Consult generator sizing form in the back of this manual to determine the proper size generator to power all electrical equipment.

The heater and facer drive unit plugs into electrical outlets on HPU (B). The left receptacle is for facer drive unit and right receptacle is for heater.

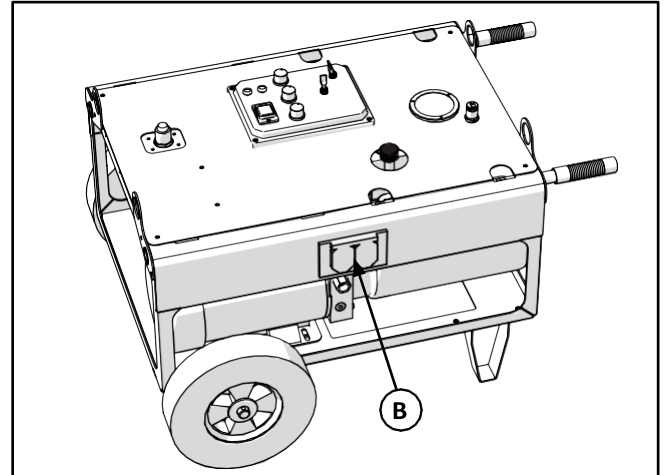

CD02217-5-14-18

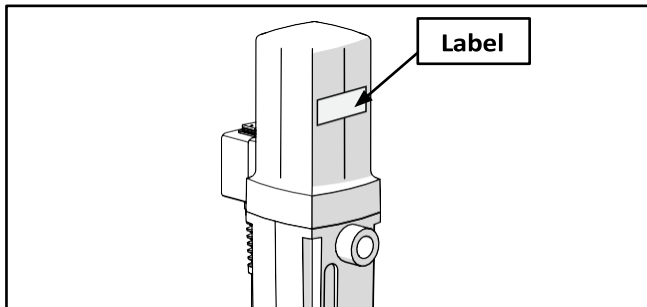

CD02250-5-14-18

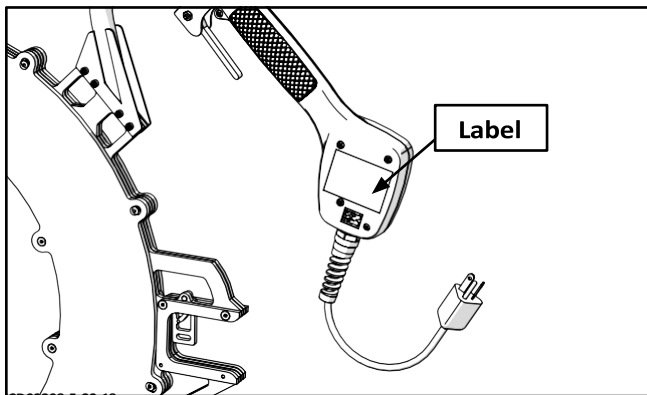

CD02208-5-23-18

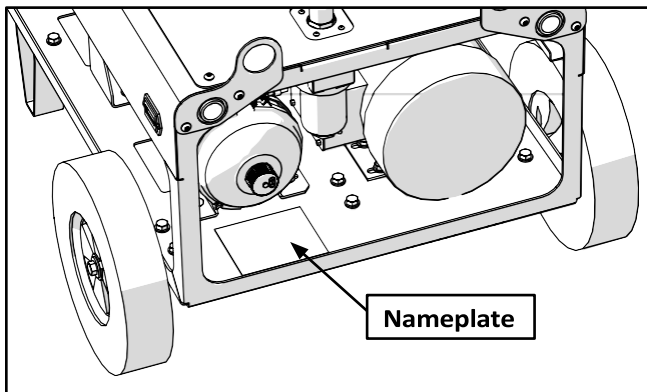

CD02252-5-23-18

## Prepare Heater

**⚠ DANGER**

This heater is not explosion proof. Operation of heater in an explosive atmosphere without necessary safety precautions will result in serious injury or death.

When operating in an explosive atmosphere, the heater should be brought up to temperature in a safe environment, then unplugged before entering the explosive atmosphere for fusion.

- 1) Install butt fusion heater plates.

**NOTICE:** The heater should never be used without butt fusion heater plates installed. Refer to the [“Changing Heater Plates/Adapters”](#) section of this manual for installation procedure.

**⚠ CAUTION**

The heater is hot and will burn clothing and skin. Keep the heater in its insulated heater stand or blanket when not in use, and use care when heating the pipe.

- 2) Place heater in insulated heater stand.

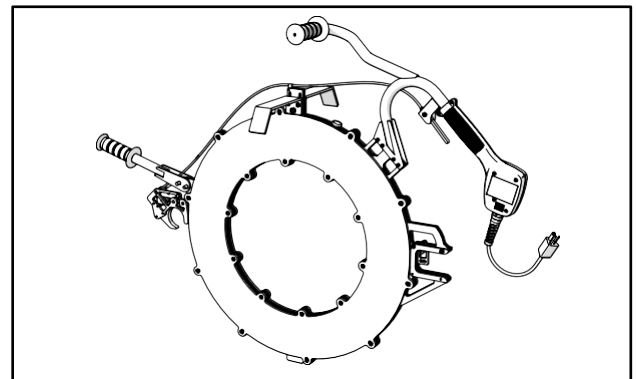

CD02208-6-14-18

- 3) Rotate guide rod adjustment block down for use with larger size carriage, rotate up for smaller size carriage.

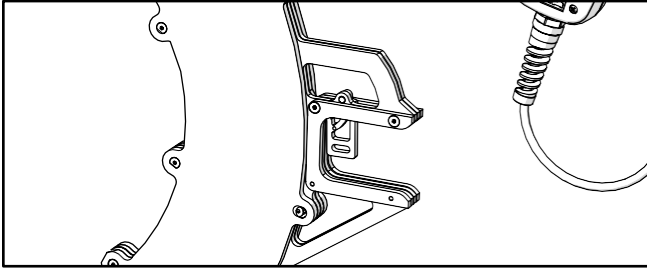

CD02208-6-14-18

- 4) Remove pin (A) above guide rod latch to adjust heater guide rod spacing. Position latch inward (B) for small carriage size and outward (C) for larger carriage size. Insert pin into aligned holes.

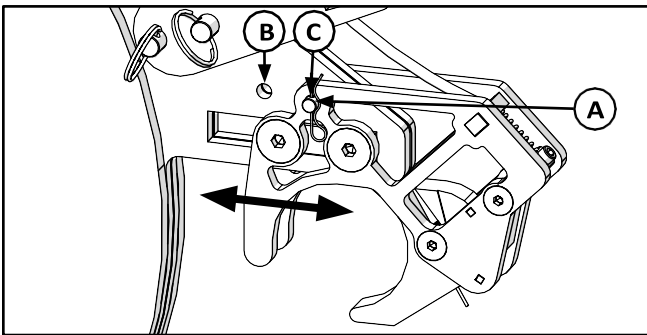

CD02276-6-14-18

- 5) Plug heater into right electrical receptacle on HPU.

### Adjusting Heater Temperature:

- 6) Turn knob to desired temperature. Allow heater to reach temperature. Measure the heater surface temperature with a pyrometer. Any variance must be corrected to the pyrometer reading.

Loosen set screw in the knob. Turn knob to point to the temperature of the pyrometer reading. Tighten set screw in the knob.

Turn knob to desired temperature. Allow heater to stabilize at the new temperature (5 to 10 minutes) after adjusting.

The thermometer on the heater body indicates internal temperature and should be used as a reference only.

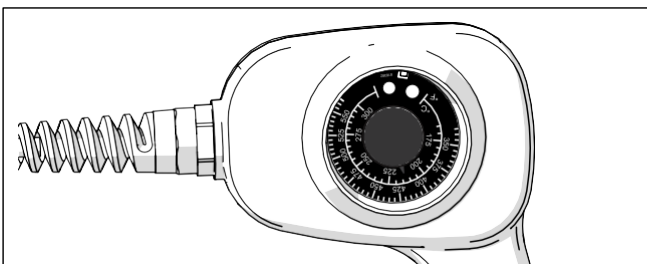

CD02152-2-21-18

The heater has a green indicator light which will flash on and off. This indicates that the controller is operating normally. If the green indicator is not flashing then the controller may not be operating properly. If this occurs, disconnect power and have the heater repaired by an McElroy Authorized Service Center.

The heater has a red indicator light on the handle at the bottom of the temperature scale. When the heater is plugged in and preheating the red light glows steadily until the set temperature is reached. The red light then goes off and on as the heater maintains temperature.

If the heater is not operating properly, the control will attempt to turn the heater off and the red indicator light will flash rapidly. If this occurs, disconnect the power and take it to a McElroy Authorized Service Center for repair.

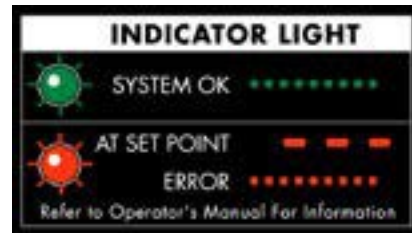

PH02571-2-21-18

- 7) Allow heater to warm-up to operating temperature.

## Hydraulic Power Unit (HPU)

**⚠ DANGER**

All electrical equipment and power sources must be located in a non-explosive atmosphere. Failure to do so will result in serious injury or death.

Locate HPU in a safe environment. Plug the electrical cord into a proper power source.

- 1) Turn on main power switch (A).

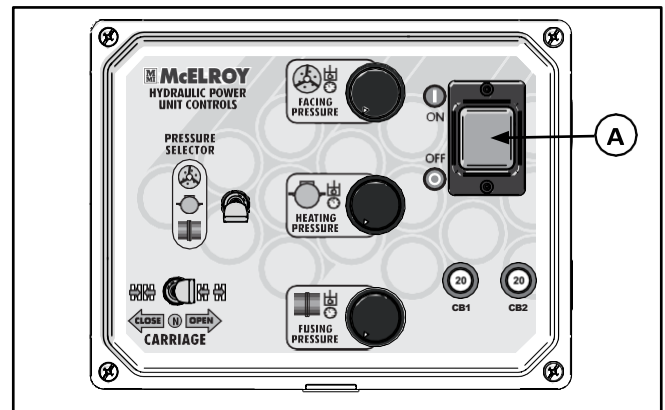

CD02218-5-14-18

## Connect HPU to QuikFit™ Carriage

- 1) With HPU on, adjust pressure to its minimum setting, then turn HPU off.
- 2) Remove dust caps for hydraulic cylinder and HPU hoses.
- 3) Screw female quick disconnect onto male quick disconnect. Screw connectors together until yellow o-ring (D) is not visible.

### ⚠ WARNING

Escaping fluid under pressure can penetrate the skin causing serious injury. Keep hands and body away from pinholes which eject fluid under pressure. Use a piece of cardboard or paper to search for leaks. If any fluid is injected into the skin, it must be immediately removed by a doctor familiar with this type of injury.

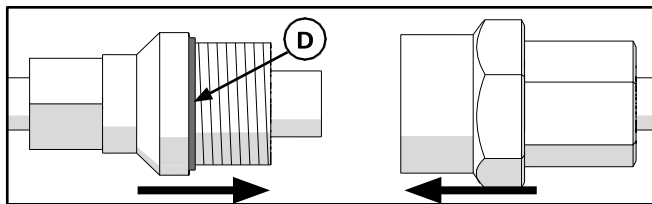

CD02253-5-23-18

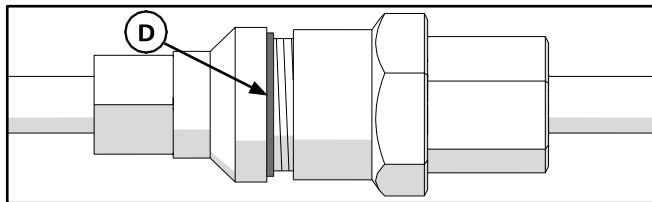

CD02254-5-23-18

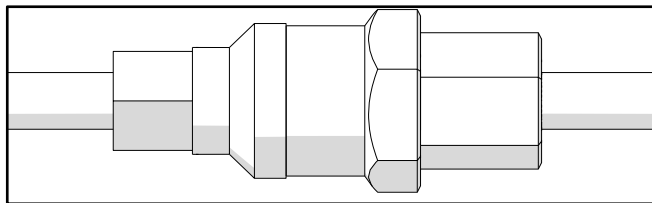

CD02255-5-23-18

## Prepare Facer

### ⚠ DANGER

Electric motors are not explosion proof. Operation of these components in an explosive atmosphere without necessary safety precautions will result in serious injury or death.

- 1) Assemble facer drive unit, refer to [Assemble Facer Drive Unit](#) for information on assembling facer drive unit.
- 2) Ensure facer drive unit power switch is in off position.
- 3) Inspect the facer blades on the blade holder for damage or dullness. Replace damaged or dull blades. Refer to “[Facer Blades](#)” in the Maintenance section for information about facer blades.
- 4) Plug facer into left electrical receptacle on HPU.

**IMPORTANT:** When the facer is on, the heater receptacle will be disabled.

### ⚠ WARNING

Facer blades are sharp and can cut. Never attempt to remove shavings while the facer is running, or is in the facing position between the jaws. Use care when operating the facer, and when handling the unit.

**NOTICE:** Never extend the facer blades beyond the inner or outer circumference of the facer.

The facer blades can be mounted in two positions: one will expel pipe material out of the pipe and the second will push pipe material inside the pipe.

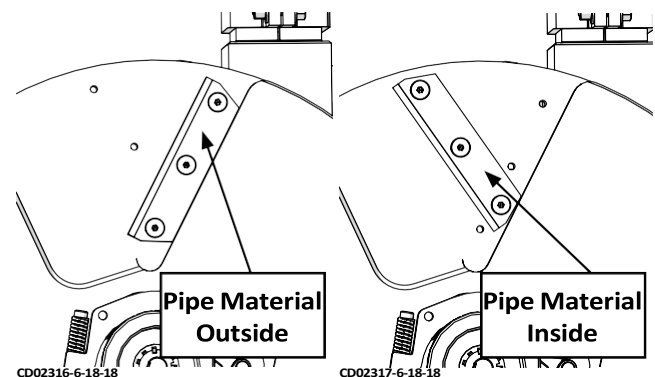

CD02316-6-18-18

CD02317-6-18-18

# Hydraulic Pressure

The pressure gauge indicates the pressure at the carriage directional control. The pressure shown on the gauge is determined by the position of the pressure selector and the pressure setting of the selected pressure reducing knobs.

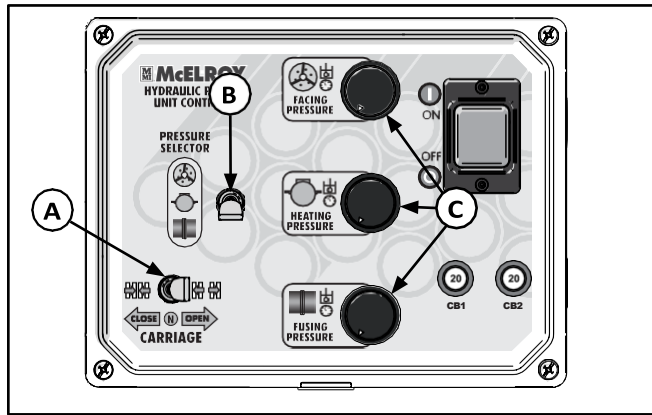

CD02218-5-14-18

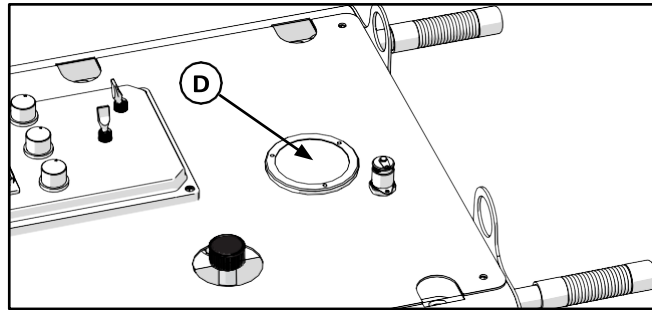

CD02217-5-14-18

- A - Carriage Directional Control
- B - Pressure Selector Control
- C - Pressure Reducing Knobs (3)
- D - Carriage Pressure Gauge

- 2) Relieve pressure in the system. Turn off HPU. Disconnect hoses from the carriage.

**WARNING**

**Disconnect carriage from HPU before attaching carriage to pipe. Carriage is operated remotely and remote operation could result in minor to moderate injury.**

- 3) Secure carriage and position carriage assembly around the pipes with the fixed jaws positioned around the bottom pipe. The upper jaws of the carriage can be removed to help with positioning the carriage into position. Once the carriage is around the pipes, reinstall the upper jaws to the carriage.

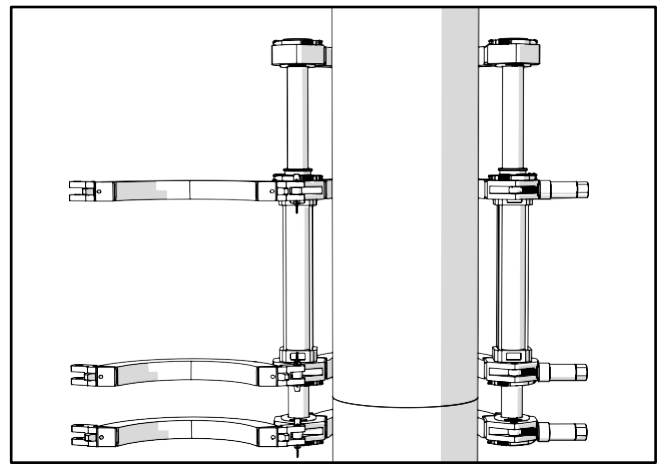

CD02293-5-23-18

The carriage may also be assembled on the pipes piece by piece until the carriage is completely assembled. Refer to [Assemble Carriage](#) for instructions on assembling carriage.

- 4) Close the fixed jaws on the pipe. Allow at least 1" (25mm) of pipe protruding from fixed jaws, any additional pipe protruding will be pipe material that will be removed during facing. Tighten the clamp knobs on the fixed jaws.

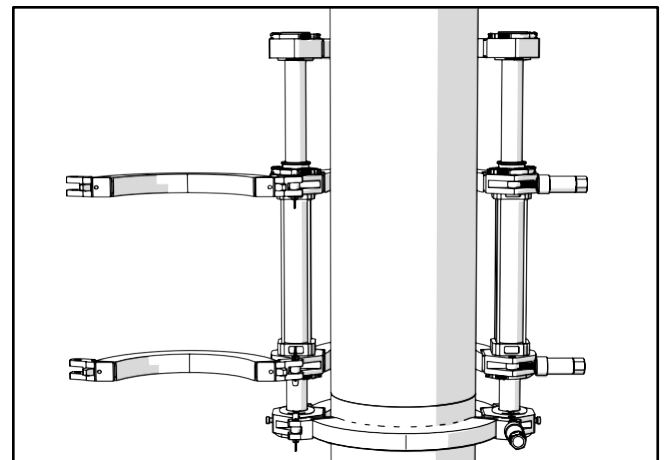

## Attach Carriage to Pipe

- 1) Position the pipe to be fused on top of fixed pipe.

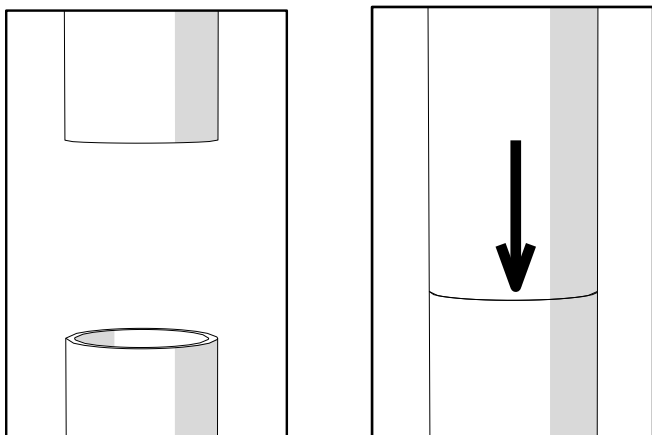

- 5) With HPU off, connect hydraulic hoses to carriage. Ensure carriage control is in neutral position.
- 6) Turn on HPU.
- 7) Use carriage directional control to slowly close carriage. Allow carriage to close until there is at least 1.25" (32mm) of pipe protruding from the movable jaws, any additional pipe protruding will be pipe material that will be removed during facing.

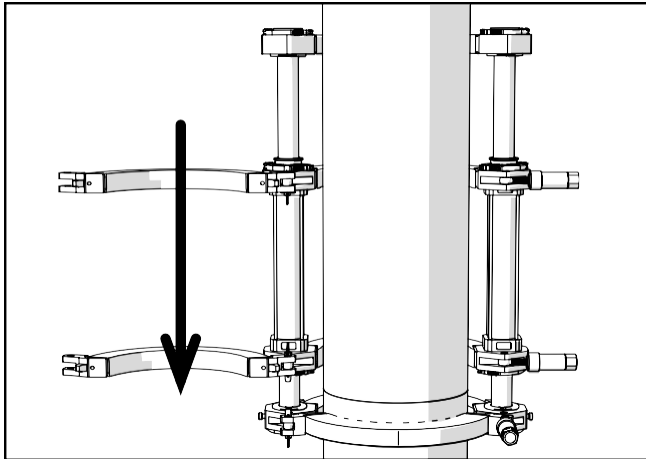

CD02294-5-23-18

- 8) Stop carriage and close movable jaws on pipe. Tighten the clamp knobs on movable jaws.

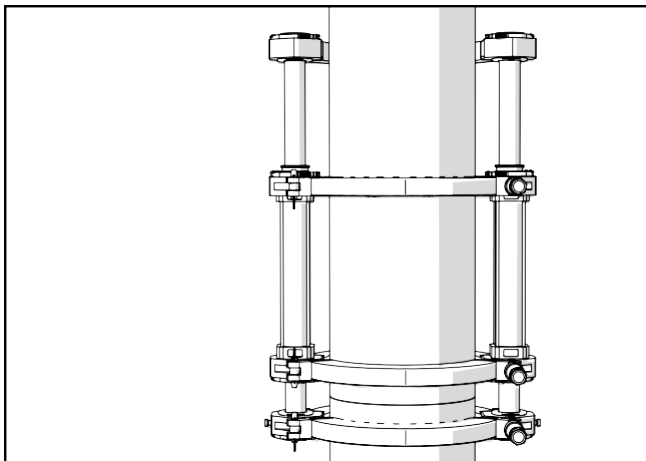

CD02295-5-23-18

- 9) Open carriage

## Facing the Pipe

- 1) Open carriage and install the facer drive unit, ensuring facer rests on carriage guide rod. Rotate guide rod latch to lock facer drive unit to guide rod.

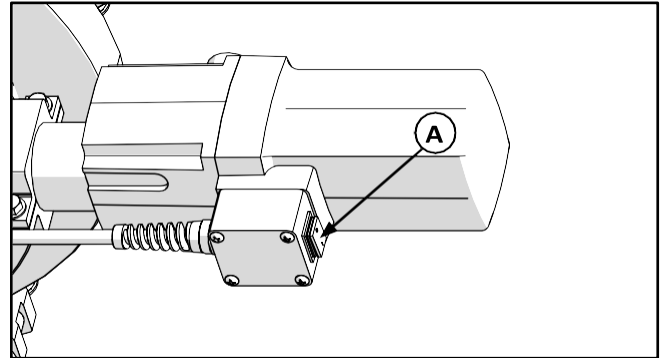

CD02271-5-14-18

- 2) Turn on the facer drive unit (A).

Ensure the pressure selector control is in the facing position.

- 3) Close the carriage.

If the facer stalls, reduce the facing pressure so the facer continues to cut.

- 4) Continue facing until both jaws contact the facer stops on both sides.

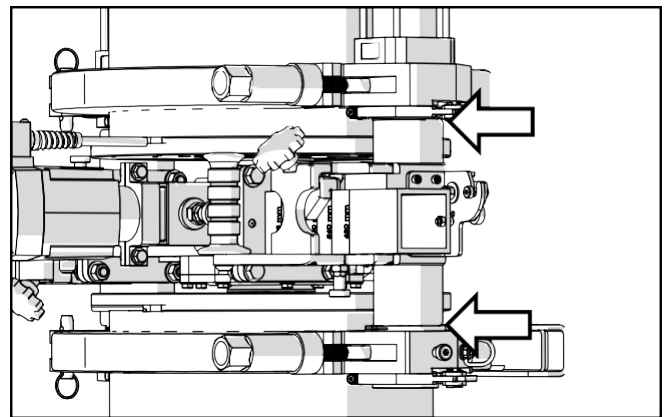

CD02287-5-14-18

- 5) Switch the carriage directional control to the neutral position.

Allow the facer to run for several revolutions to ensure that there are no chips hanging on the end of the pipe.

- 6) Turn facer off.

Ensure the facer has come to a complete stop.

- 7) Move the carriage directional control to the right to open the carriage.
- 8) Turn off the HPU.
- 9) Rotate and release guide rod latch, and lift the facer drive unit out.
- 10) Remove chips from pipe ends.

Do not touch faced pipe ends.

- 11) Inspect both pipe ends for complete face off. If the face off is incomplete, return to [Attach Carriage to Pipe](#).

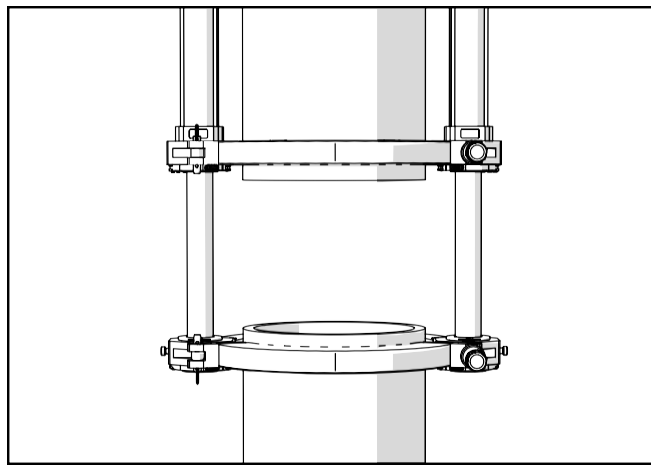

- 12) Turn on the HPU.

## Check Alignment

- 1) Close the carriage until the ends of the pipe butt together.
- 2) Check pipes for alignment.

### **⚠ WARNING**

**Do not use finger to check for HI/LO (misalignment). The unit is under pressure, and slippage could result in crushed fingers. Always keep hands clear of the jaw area.**

If pipe is not lined up, tighten the high side jaw to bring into alignment. Refer to pipe manufacturer's recommendations or appropriate joining standard for proper alignment. Reinsert the facer and reface the pipe.

**IMPORTANT:** Always tighten the side that is higher, never loosen the low side.

When the pipe is properly aligned tighten outside clamps to insure against slippage.

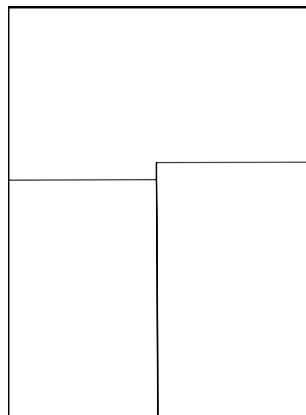

CD02275-5-14-18

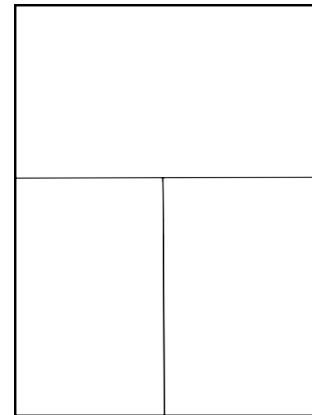

CD02274-5-14-18

**NOTICE:** When clamping, do not over-tighten the clamp knobs because machine damage can result. Check to see if there is space between the upper and lower jaws. If the two jaws are touching, do not continue to tighten.

Ensure there is no unacceptable gap between the pipe ends. If there is unacceptable gap, reinsert facer and reface.

- 3) Close the carriage and check for slippage. Apply fusion pressure and inspect if the pipes slip. If slippage occurs, return to [Attach Carriage to Pipe](#).

## Set Hydraulic Pressures

The weight of the top pipe will be pushing down on the carriage. This extra force must be taken into account when setting pressures for vertical fusion.

### Set Heating (Drag) Pressure:

- 1) Close carriage.
- 2) Shift pressure selector to heating (drag) pressure.
- 3) Turn the heating pressure reducing knob to its lowest setting.
- 4) Move carriage directional control to the open position.
- 5) Turn the pressure reducing knob to increase pressure until the carriage starts moving up then back off until the carriage stops. Then turn the pressure reducing knob to decrease pressure until the carriage starts moving down then increase until the carriage stops.
- 6) Repeat steps 1-5 to confirm heating (drag) pressure.

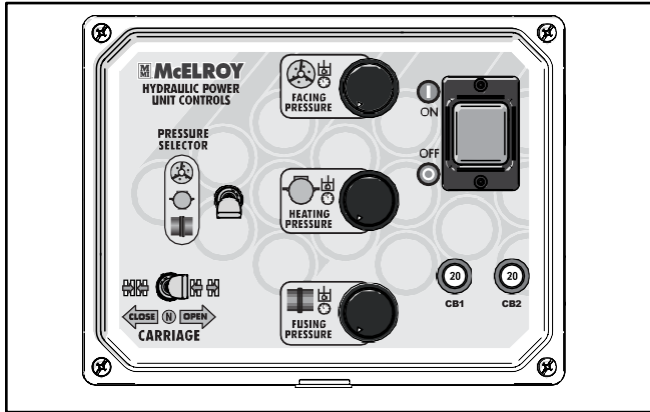

CD02218-5-14-18

The heating pressure will represent the same as drag pressure on a horizontal fusion.

**NOTICE:** Setting the proper heating (drag) pressure will prevent the carriage from moving away or moving toward the fusion joint resulting in a improperly made fusion joint.

**Set Facing Pressure:** Switch pressure selector to facing pressure. Turn the facing pressure reducing knob to increase pressure until the carriage can lift the pipe quickly (facing pressure will be higher than heating pressure).

**Set Fusing Pressure:** To calculate the vertical fusion pressure, calculate the theoretical fusion pressure and subtract the heating pressure. The heating pressure must be subtracted or the weight of the pipe will apply too much force and squeeze out the melt.

Set fusing pressure to the absolute value of the calculation.

**Vertical Fusion Pressure = Theoretical Fusion Pressure - Heating (Drag) Pressure**

**IMPORTANT:** Follow the appropriate heating and fusing procedure based on either a positive or negative vertical fusion pressure calculation.

## Insert Heater

**NOTICE:** Incorrect heating temperature can result in questionable fusion joints. Check heater plates periodically with a pyrometer and make necessary adjustments.

Refer to [“Prepare Heater”](#) section for how to adjust heater temperature.

- 1) Check heater surface temperature with a pyrometer.

Refer to the pipe manufacturer’s recommendations or appropriate joining standard for proper heater temperature.

**IMPORTANT:** The dial thermometer on the heater indicates internal temperature which varies from the actual surface temperature.

The dial thermometer can be used as reference once the surface temperature has been verified and is never a substitute for actual surface temperature.

**! DANGER**

**This heater is not explosion proof. Operation of heater in an explosive atmosphere without necessary safety precautions will result in serious injury or death.**

- 2) Use a clean dry lint free non-synthetic cloth to clean the butt fusion heater plates.

**! CAUTION**

**The heater is hot and will burn clothing and skin. Keep the heater in its insulated heater stand or blanket when not in use, and use care when heating the pipe.**

- 3) Open the carriage until there is a gap large enough to insert the heater.

**NOTICE:** Do not open a gap too large as this could damage the heater stripper bar.

- 4) Insert heater between pipe ends.
- 5) Ensure the guide rod latch engages the guide rod.

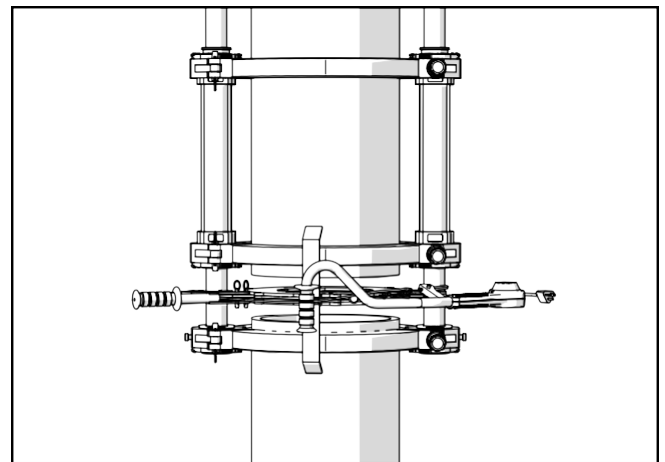

CD02297-5-23-18

## Heating the Pipe (Positive Vertical Fusion Pressure)

- 1) Verify that the pressure selector control is in the fusing position.

- 2) Close the carriage to bring pipe ends in contact with the heater. Allow for bead-up according to pipe manufacturer's or appropriate joining standard recommendations.
- Ensure the heater stays perpendicular to the pipe by supporting the heater during the heating process.
- 3) After proper bead-up, move pressure selector control to middle (heating mode) position.
  - 4) Switch the carriage directional control to the open position.

**NOTICE:** Ensure that the pipe remains in contact with heater throughout the entire process. If the pipe loses contact with the heater, abort the joint and go to ["Attach Carriage to Pipe"](#).

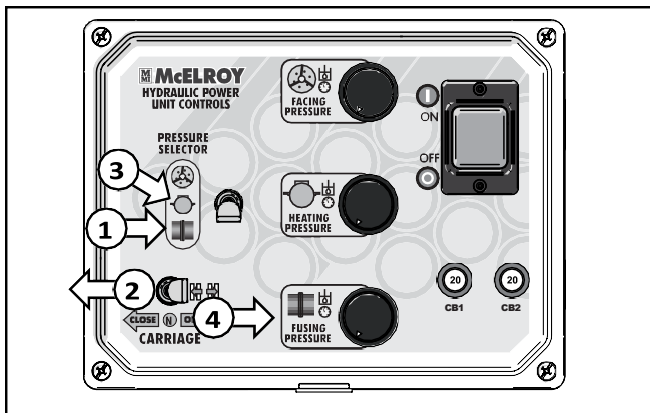

CD02218-5-14-18

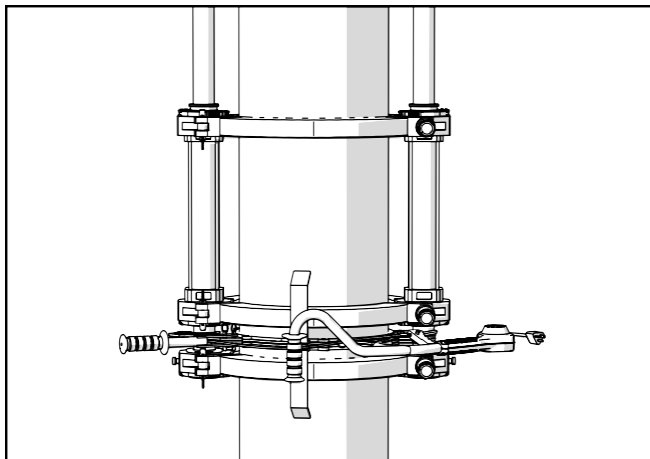

CD02298-5-23-18

After following the pipe manufacturer's suggested heating procedure:

- 1) Shift carriage directional control to neutral position.
- 2) Shift the pressure selector to facing position.
- 3) Open the carriage just enough to remove the heater. Quickly remove the heater by grabbing the heater guide rod latch release lever and pulling it into the handle of the heater to release from the guide rod. Inspect pipe ends for appropriate melt.
- 4) Shift the pressure selector control to fusing pressure.
- 5) Quickly close the carriage, bringing the pipe ends together under the vertical fusion pressure.

Allow joint to cool under pressure according to pipe manufacturer's or appropriate joining standard's recommendations.

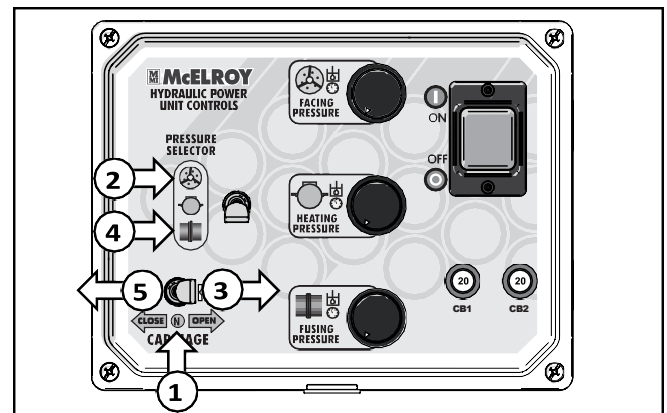

CD02218-5-14-18

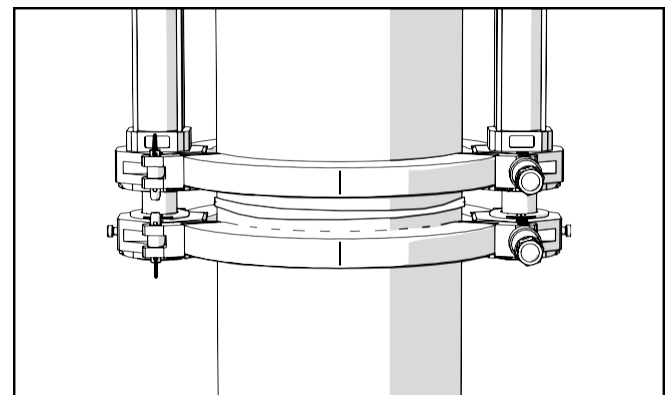

CD02299-5-23-18

## Fusing the Pipe (Positive Vertical Fusion Pressure)

**NOTICE:** Failure to follow pipe manufacturer's fusion procedures may result in a questionable joint.



## Heating the Pipe (Negative Vertical Fusion Pressure)

- 1) Verify that the pressure selector control is in the fusing position.
- 2) Close the carriage to bring pipe ends in contact with the heater.
- 3) When pipe ends contact the heater, immediately shift the carriage directional control to the open position. Allow for bead-up according to pipe manufacturer's or appropriate joining standard recommendations.

Ensure the heater stays perpendicular to the pipe by supporting the heater during the heating process.

- 4) After the proper bead-up, switch pressure selector control to middle (heating mode) position.

**NOTICE:** Ensure that the pipe remains in contact with heater throughout the entire process. If the pipe loses contact with the heater, abort the joint and go to ["Attach Carriage to Pipe"](#).

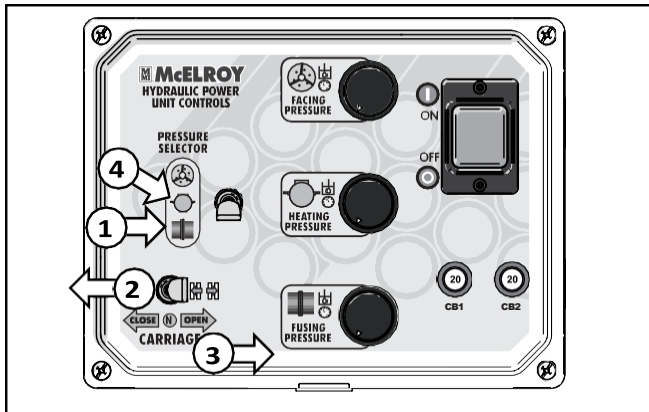

CD02218-5-14-18

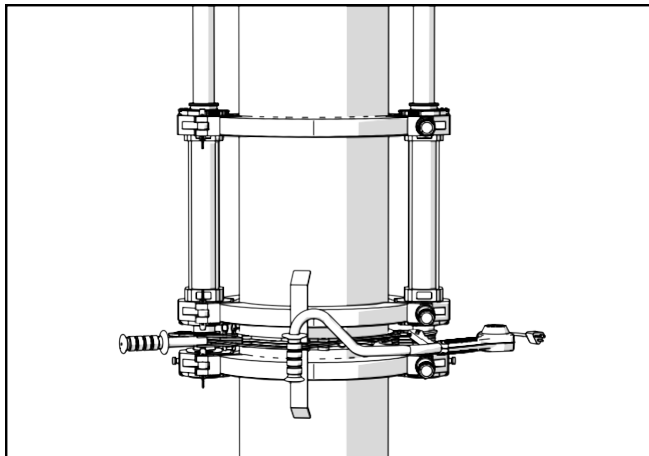

CD02298-5-23-18

## Fusing the Pipe (Negative Vertical Fusion Pressure)

**NOTICE:** Failure to follow pipe manufacturer's fusion procedures may result in a questionable joint.

After following the pipe manufacturer's suggested heating procedure:

- 1) Shift carriage directional control to neutral position.
- 2) Shift the pressure selector to facing position.
- 3) Open the carriage just enough to remove the heater.

Quickly remove the heater by grabbing the heater guide rod latch release lever and pulling it into the handle of the heater to release from the guide rod. Inspect pipe ends for appropriate melt.

- 4) Shift the pressure selector control to fusing pressure.
- 5) Quickly close the carriage, bringing the pipe ends together then shift the carriage to the open position (3).

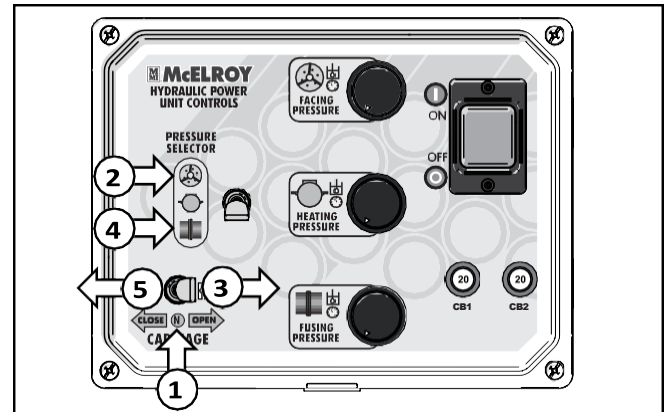

CD02218-5-14-18

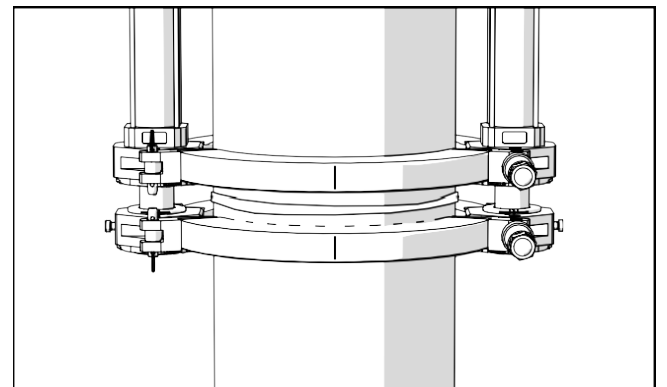

CD02299-5-23-18

**NOTICE:** The carriage will move quickly so ensure the pipe ends do not make contact while closing the carriage. Closing under that pressure will push the melt out of the fusion area. If that happens, cut out the fusion joint and repeat the steps to fuse the pipe.

Allow joint to cool under pressure according to pipe manufacturer's or appropriate joining standard's recommendations.

## Opening Jaws

- 1) After the joint has cooled for the pipe manufacturer's or appropriate joining standard recommended time, shift the carriage directional control to the neutral position.
- 2) Relieve hydraulic pressure in the carriage by turning fusing pressure reducing knob to its minimum setting.
- 3) Turn off the HPU.
- 4) Disconnect the hydraulic hoses from the carriage.
- 5) Ensure the pipe is supported before removing the carriage from pipe. Loosen the clamp knobs on movable jaws and open the jaws.

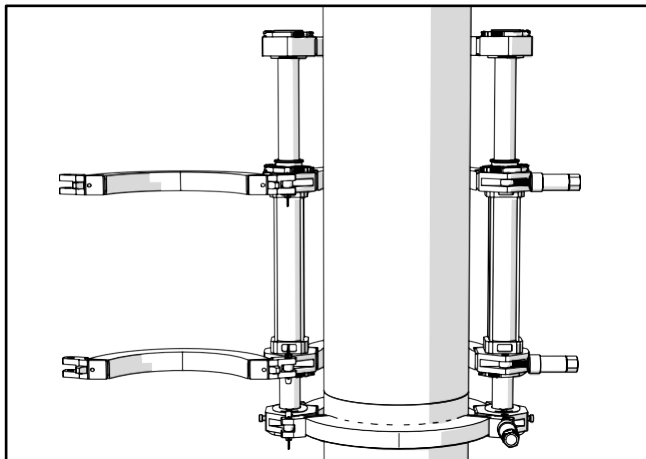

- 6) Support the carriage and loosen the clamp knobs on the fixed jaws and open the jaws.

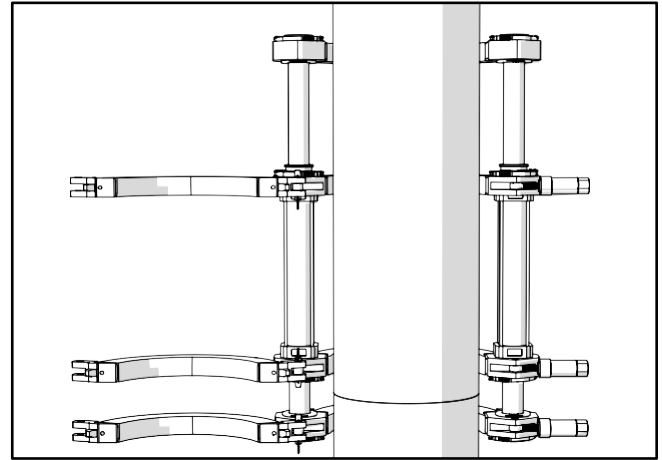

- 7) Rotate the carriage out from around the pipe.  
The carriage can also be disassembled piece by piece from the pipe as an alternative method of removal.
- 8) The upper jaws may need to be removed to remove the carriage from the pipe.

# STORAGE/TRANSPORT

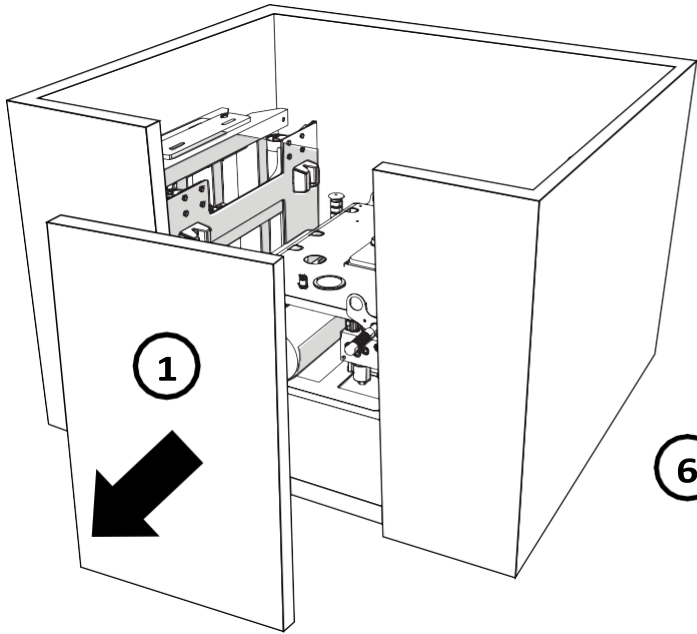

CD02212-5-14-18

## Pack Acrobat™ Packages

### Pack Core Package:

- 1) Remove front panel of crate.
- 2) Place both cylinder assemblies into crate.
- 3) Remove facer blade holders and facer drive motor from facer. Place facer drive unit into crate. Use a two man lift or use lift point to lift using an overhead lifting device.
- 4) Place facer drive motor in crate.
- 5) Roll HPU into crate through front panel opening.
- 6) Fold and lock carriage skid together. Place carriage skid in crate.
- 7) Fold down handle of heater/facer cart. Place heater/facer cart in crate with wheels facing outward.

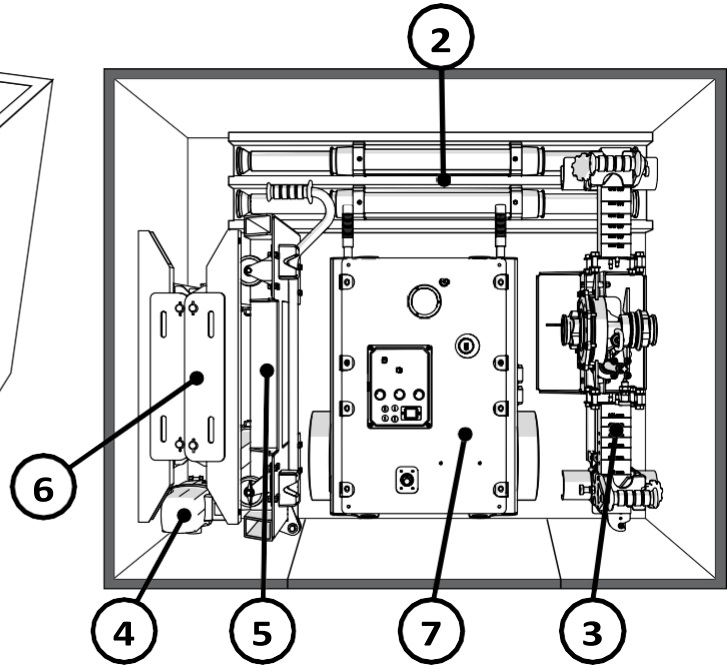

CD02213-5-14-18

8) Use D-rings inside crate with ratchet straps to secure all components to bottom of crate.

9) Replace front panel of crate.

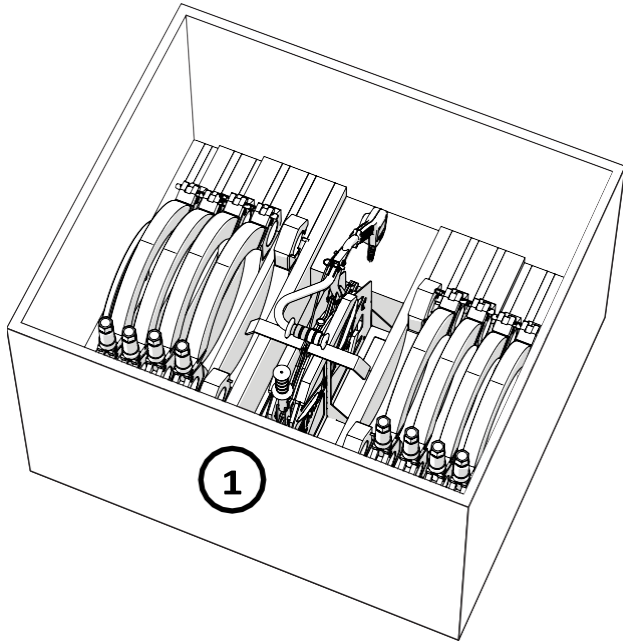

CD02214-5-14-18

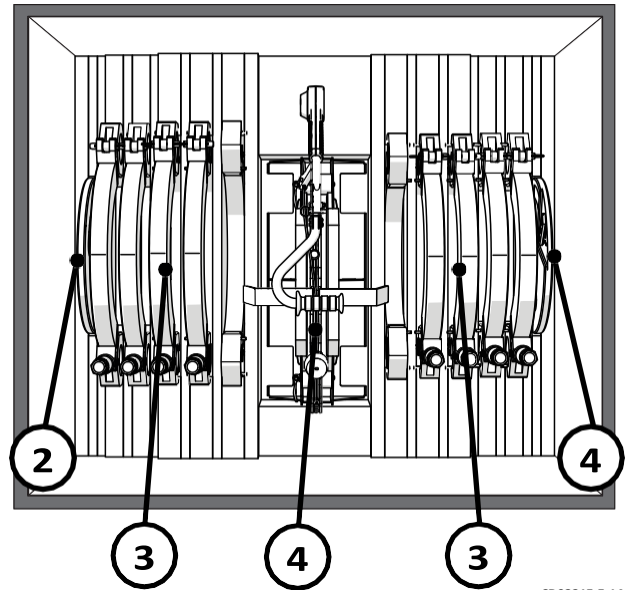

CD02215-5-14-18

### Pack Heater/Jaw Package:

- 1) Open heater/jaw package crate.
- 2) Place both facer blade holders into crate.
- 3) Place the jaw sets into the crate one size on each side of heater. Place the guide rod support in the slot close to the heater.
- 4) Place heater and heater bag into crate.
- 5) Use D-rings inside crate with cinch straps to secure all components to bottom of crate.
- 6) Replace crate lid.

# MAINTENANCE

Task	As Needed	Daily	Monthly	Yearly	500 hrs
Clean Machine	-				
Check Machine Operation		-			
Fasteners Are Tight			-		
Clean Eyebolt and Thrust Bearing	-				
Changing Heater Plates/Adapters	-				
Facer Blades	-				
Change Hydraulic Fluid and Filter					-
Change Facer Gear Oil	-				
Bleeding Air from Hydraulic System	-				
Bleeding Air from HPU	-				

## Preventative Maintenance

To insure optimum performance, the machine must be kept clean and well maintained.

With reasonable care, this machine will give years of service. Therefore, it is important that a regular schedule of preventive maintenance be kept.

Store machine inside, out of the weather, whenever possible.

- 4) Inspect the jaw clamps for proper operation. Replace any damaged jaw clamps.
- 5) Assemble facer drive unit and operate facer to inspect for proper operation. Do not operate facer if it is not operating properly.
- 6) Plug in heater and check for heater to reach set heater temperature. Allow several minutes for heater to reach set temperature. If the heater doesn't reach set temperature, contact technical services for troubleshooting assistance.

**Whenever a question arises regarding your machine, please contact McElroy Technical Services at 918-831-9224 or [techsupport@mcelroy.com](mailto:techsupport@mcelroy.com)**

## Clean Machine

- 1) Clean the machine with soap and water as needed.  
Do not pressure wash.

## Check Machine Operation

- 1) Operate carriage using controls on HPU. Select each of the three pressure settings and ensure they each build pressure. Rotate the respective knob to adjust pressure. Actuate the carriage direction control in all positions and ensure the carriage functions accordingly.
- 2) Open and close the carriage of the machine. Check for smooth opening and closing motion. If movement is erratic, the hydraulic system may need to be bled.
- 3) Close the carriage to the end of travel. Build pressure on the gauge, inspect gauge to ensure it is working properly.

## Fasteners Are Tight

- 1) Inspect all machine fasteners for tightness. Tighten any loose fasteners.

## Clean Eyebolt and Thrust Bearing

- 1) Brush the clamp knob eyebolt threads to keep them clean.
- 2) The thrust bearings located in the clamp knobs must turn freely.

Wash the clamp knob bearing assembly with a solvent, and then lubricate with 30W or lighter oil.

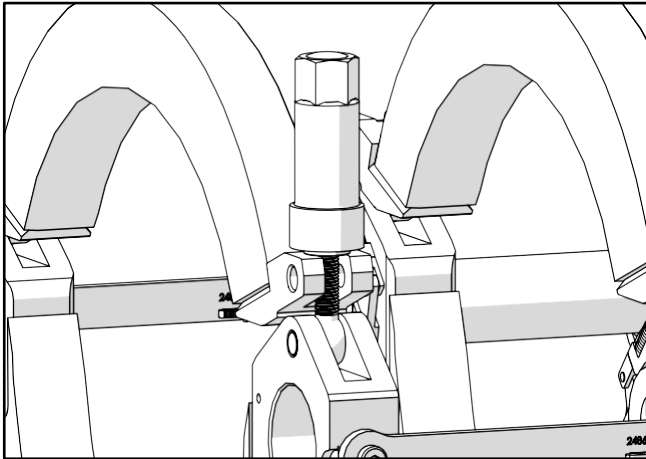

CD02304-6-14-18

## Changing Heater Plates/ Adapters

The heater body of this assembly is not coated. Coated heater plates/adapters are available for all fusion applications.

Heater plates/adapters are installed with stainless steel cap screws.

Care should be taken to assure that the heater adapters are seated on the heater body, and that there is no foreign matter trapped between these surfaces.

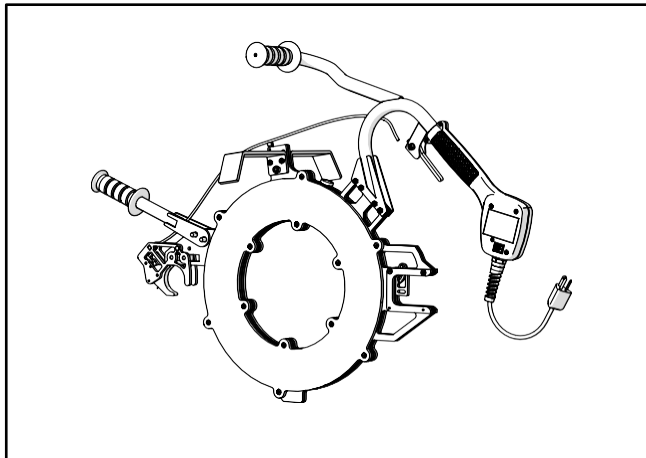

CD02303-6-14-18

**IMPORTANT:** Do not over-tighten the bolts.

The surface of the heater adapters are coated with an anti-stick coating.

**NOTICE:** Only install heater adapters when the heater is cool.

## Facer Blades

Blades bolt directly to the blade holder and should be inspected for damage and sharpness.

- 1) Dull or chipped blades must be replaced.

**NOTICE:** Never extend the blade beyond the inner or outer circumference of the facer.

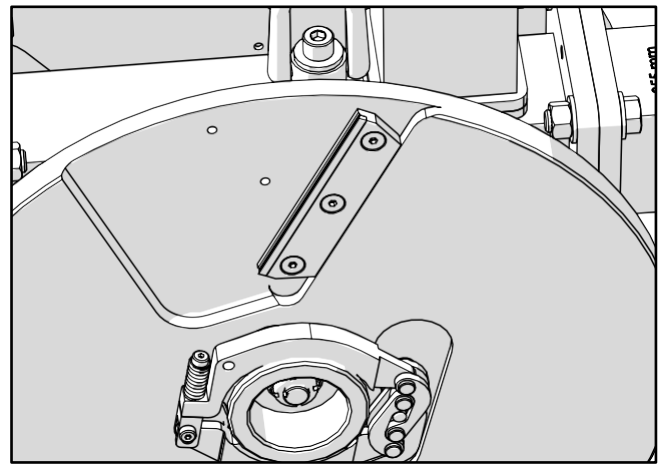

CD02305-6-14-18

## Change Hydraulic Fluid and Filter

This HPU is equipped with a 3 micron pressure filter with a bypass indicator. If the indicator is activated, the filter needs to be changed otherwise the filter should be replaced every 500 hours.

### Drain Hydraulic Fluid:

- 1) Ensure the HPU is unplugged from the power source and remove the two hydraulic lines from the block of power pack assembly (cover hidden for visibility).

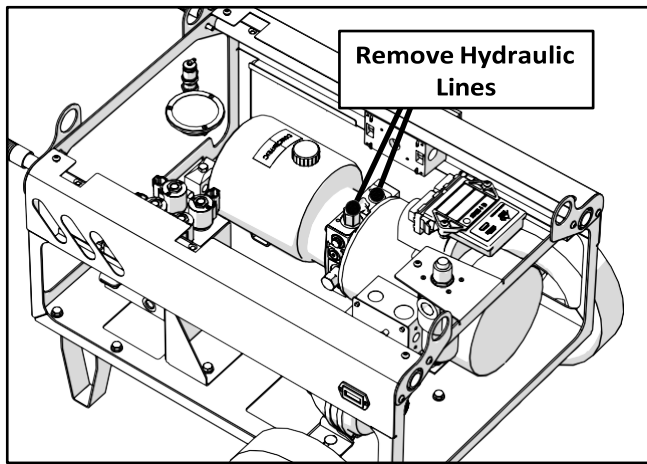

CD02300-6-14-18

- 2) Disconnect electrical connector wired to power pack assembly.
- 3) Remove 6 mounting bolts from feet of tank of power pack assembly.

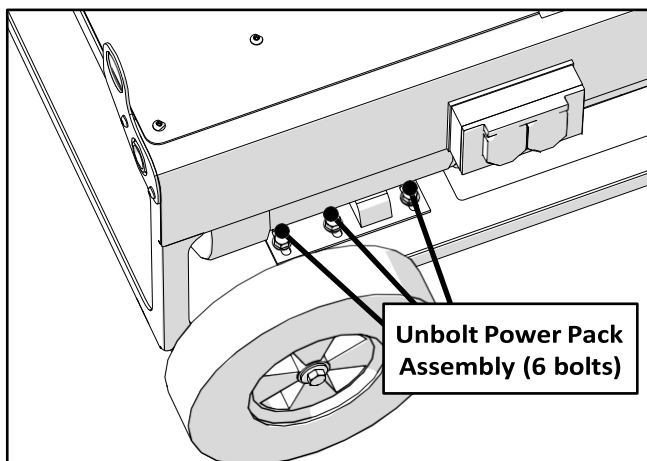

CD02301-6-14-18

- 4) Slide the power pack assembly out end of HPU frame.

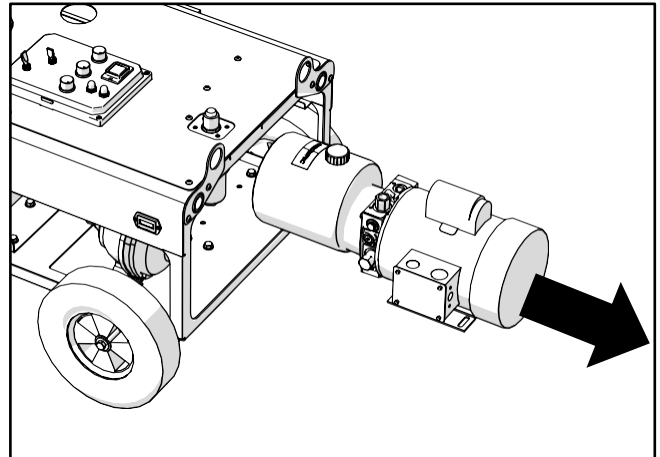

CD02302-6-14-18

- 5) Unscrew fill cap and turn power pack assembly upside down and drain fluid into a drain pan.

The hydraulic fluid should be replaced every year.

- 6) Fill the reservoir from a clean container. Refer to the ["Hydraulic Fluids"](#) section of this manual for hydraulic fluid recommendations.
- 7) Insert power pack assembly back into HPU frame. Reinstall power pack assembly using the 6 bolts on feet of tank. Reconnect electrical connection. Install the two hydraulic lines back to block of power pack assembly.

### Change Filter:

- 8) Use a wrench to remove the bowl from the filter housing. Remove the old filter cartridge and replace with a new filter cartridge. Install the bowl on the filter housing.

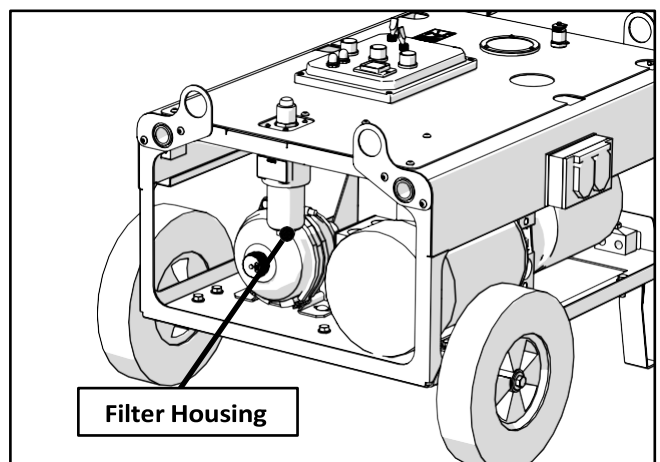

CD02306-6-14-18

## Change Facer Gear Oil

- 1) Ensure facer drive unit is unplugged from power source. Remove drive motor, both blade holders from facer drive unit.
- 2) Remove drain plug and drain oil into a drain pan.

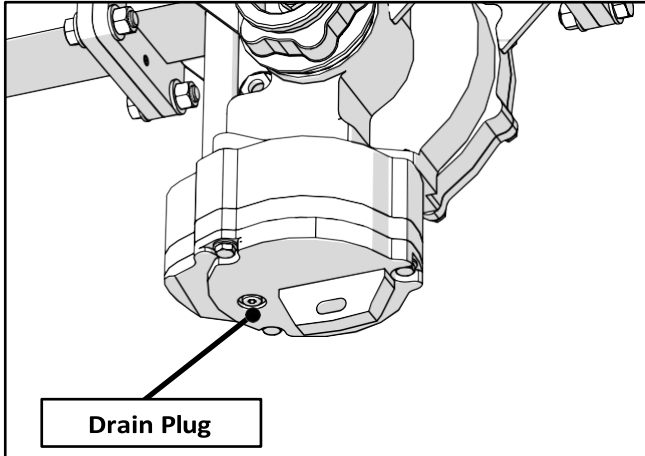

CD02307-6-14-18

- 3) Inspect drained oil for any debris. If debris is present in the oil, the gear box may have some damage inside. Contact McElroy Technical Services for assistance in addressing the gear box.

- 4) Replace drain plug.

**To fill the gear box:**

- 5) Remove sight glass plug.

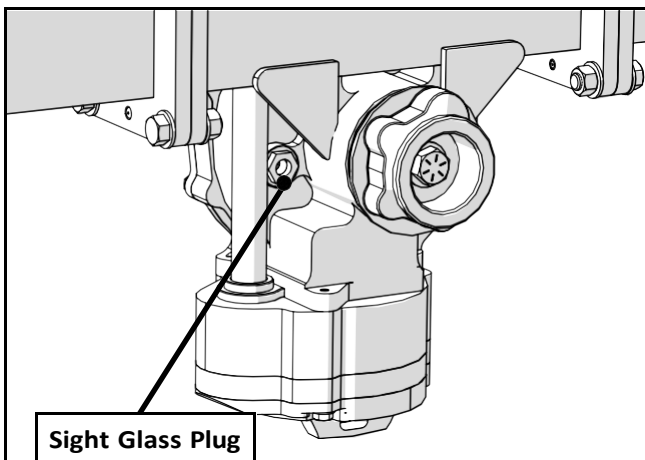

CD02308-6-14-18

- 6) Fill the gear box with approximately 24 fluid ounces (710mL) of new clean gear oil (80W/90). Fill gearbox in small amounts at a time to allow oil to pass through bearings to fill cavity.
- 7) With facer drive unit positioned upright, oil should be visible or close to sight glass plug.
- 8) Replace sight glass plug.

## Bleeding Air From Hydraulic System

The two carriage cylinders have air bleed screws and must be bled if the system ever runs low on fluid or leaks air on inlet side of pump. Air in the system is indicated when carriage movement becomes cushioned.

**To bleed the system, proceed as follows:**

The bleed screws are on the ends of the rod glands.

- 1) Use the carriage directional control to move the cylinder toward one end.
- 2) Loosen the bleed plug on the cylinder next to the end of cylinder.

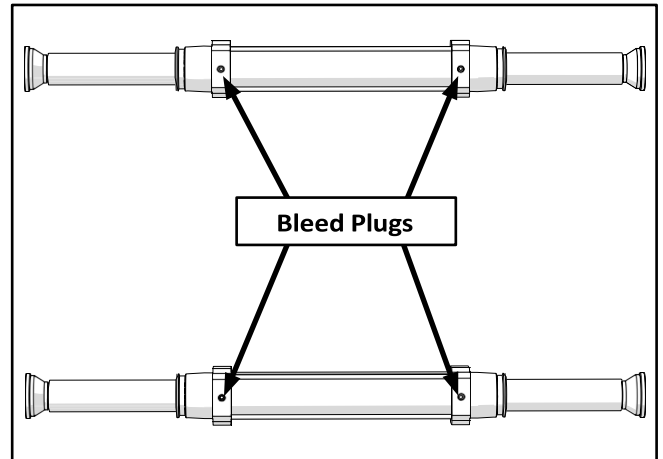

CD02318-6-14-18

- 3) Hold pressure on the cylinder until no air is indicated and quickly tighten the plug.
- 4) Repeat this operation on the opposite cylinder.
- 5) Use the carriage directional control to move the cylinder to the other end. Repeat steps 2-4 for opposite end of the cylinders.



## Bleeding Air From HPU

- 1) Fill hydraulic reservoir according to procedure "[Check Fluid Level](#)" in the Operation section of the manual.
- 2) Connect the quick disconnects together at the end of the hoses.
- 3) Move the pressure selector control (A) to fusing pressure.
- 4) Set the fusing pressure reducing knob (B) to max setting by turning the knob clockwise.
- 5) Turn the Acrobat HPU on (C) and move the carriage directional control (D) to the open position. Allow fluid to circulate for 30 seconds.
- 6) Shift the carriage directional control (D) to the close position and circulate fluid for 30 seconds.
- 7) Reduce the fusing pressure completely by turning the knob (B) counter-clockwise. Ensure zero pressure is shown on the carriage pressure gauge (E).
- 8) Turn the Acrobat HPU off (C).
- 9) Refill the hydraulic reservoir according to procedure "[Check Fluid Level](#)" in the Operation section of the manual.
- 10) Disconnect the quick disconnects at the end of the hoses.
- 11) Turn the Acrobat HPU on (C).
- 12) Move the carriage directional control (D) to the close position and set the fusing pressure between 30 and 40 PSI.
- 13) Attach a separate bleeder hose (2489701) to the DataLogger Port (F) on the HPU. Allow fluid to trickle out until all signs of air are removed. Remove the bleeder hose from the DataLogger Port (F).
- 14) Increase/decrease pressure with the fusing pressure reducing knob (B) from 0- PSI for 10 cycles.
- 15) Turn the HPU off (C) and refill the hydraulic reservoir.

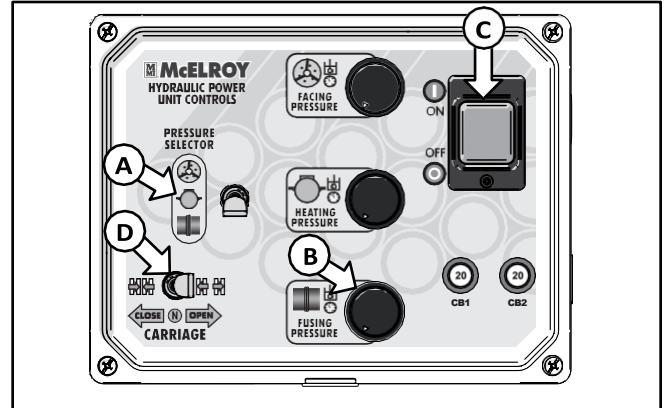

CD02218-5-14-18

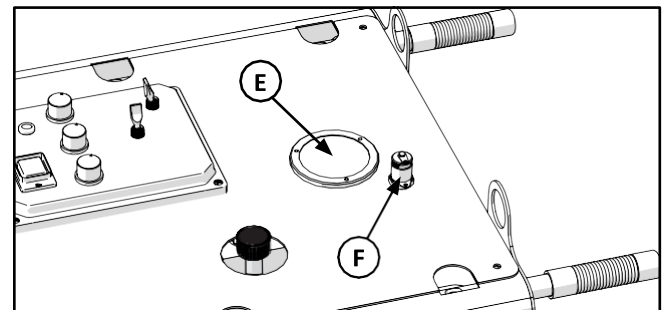

CD02217-5-14-18

# HYDRAULIC FLUIDS

## Hydraulic Fluids

The use of proper hydraulic fluid is mandatory to achieve maximum performance and machine life. Use a clean, high quality, anti-wear hydraulic fluid with a viscosity index (VI) of 135 minimum. It should have a maximum viscosity of 500 cSt (2000 SSU) at startup (ambient temperature) and a minimum viscosity of 13 cSt (65 SSU) at the maximum fluid temperature (generally 80°F above ambient). Using hydraulic fluids that do not meet these criteria may cause poor operation and/or damage to the hydraulic components.

The following table specifies the fluid temperature at various viscosities. Temperature rise of the hydraulic fluid can vary from 30° F to about 80° F over the ambient temperature depending on the pressure setting, age of the pump, wind, etc. Mobil Univis N46 hydraulic fluid is installed at our factory. The advantage of this fluid is a wider temperature range, however, this fluid should not be used for continuous operation below 24°F.

Standard Hydraulic Fluids Characteristics																	
Manufacturer	Fluid Name	cSt 100F	cSt 210F	V.I.	-20F	-10F	0F	10F	30F	50F	70F	90F	110F	130F	150F	Range °F	Range °C
Mobil	DTE 10 Excel 15	15.8	4.1	168	*****	*****	*****	*****	*****	*****	*****	*****	*****	*****	*****	-16 - 113	-27 - 45
	DTE 10 Excel 32	32.7	6.6	164				*****	*****	*****	*****	*****	*****	*****	12 - 154	-11 - 68	
	DTE 10 Excel 46	45.6	8.5	164				*****	*****	*****	*****	*****	*****	*****	23 - 173	-5 - 78	
	DTE 10 Excel 68	68.4	11.2	156				*****	*****	*****	*****	*****	*****	37 - 196		3 - 91	
	Univis N-32	34.9	6.9	164				*****	*****	*****	*****	*****	*****	*****	12 - 150	-11 - 66	
	Univis N-46	46	8.5	163				*****	*****	*****	*****	*****	*****	*****	24 - 166	-4 - 74	
	Univis N-68	73.8	12.1	160				*****	*****	*****	*****	*****	*****	39 - 193		4 - 89	

NOTE: This chart is based on pump manufacturer recommendations of 13 to 500 cSt.

NOTE: Temperatures shown are fluid temperatures. – NOT ambient temperatures.

# SPECIFICATIONS

## Specifications

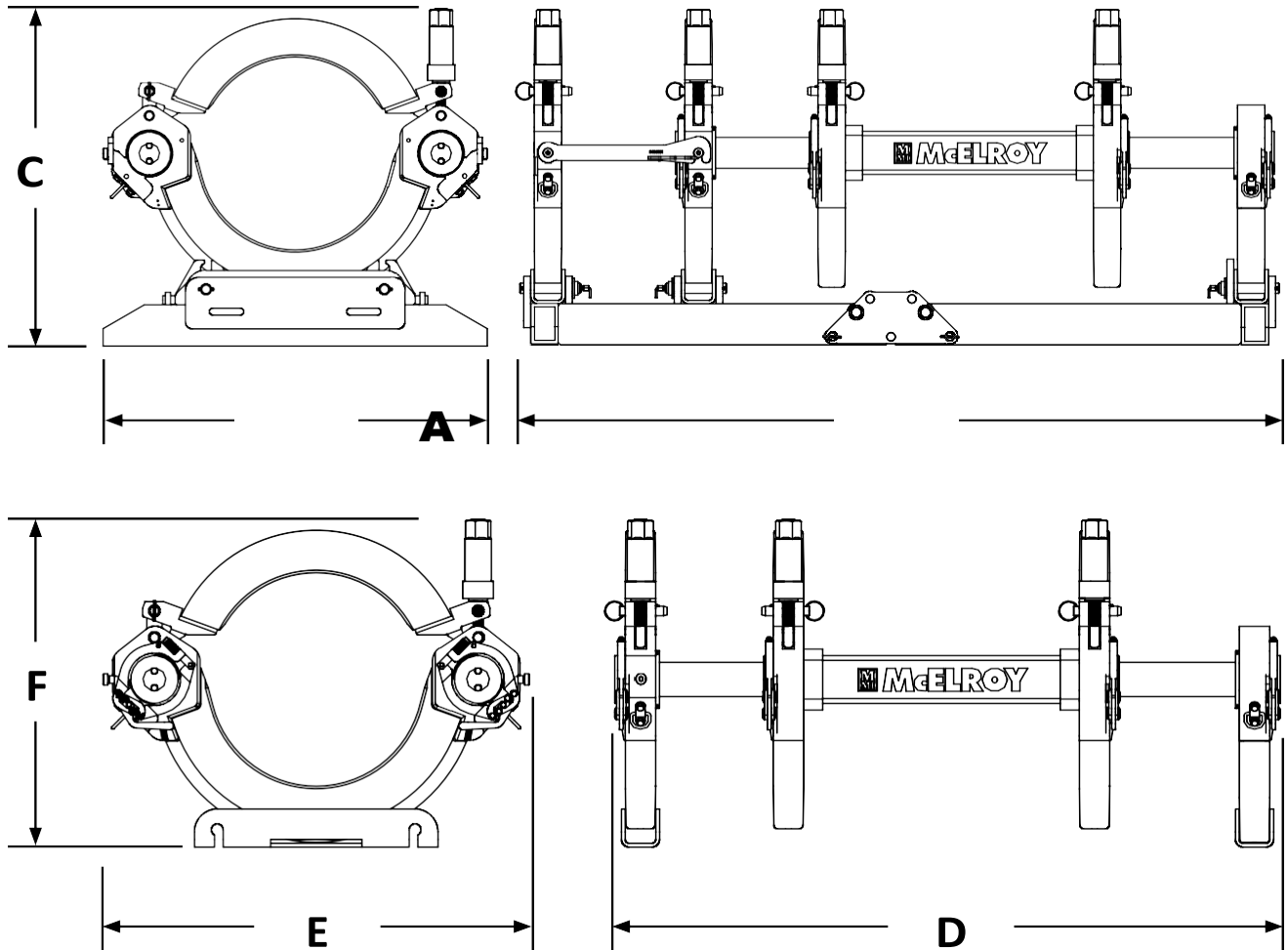

**4-Jaw QuikFit™  
Carriage Dimensions**

Size	A	B	C
355	55.5" 1410mm	28.0" 711mm	24.5" 622mm
400	55.5" 1410mm	30.0" 762mm	25.5" 648mm
450	55.5" 1410mm	32.0" 813mm	27.5" 699mm
500	55.5" 1410mm	34.0" 837mm	30.0" 762mm
560	55.5" 1410mm	36.5" 927mm	32.5" 826mm
630	55.5" 1410mm	39.5" 1003mm	35.0" 889mm

**3-Jaw QuikFit™  
Carriage Dimensions**

Size	D	E	F
355	44.0" 1118mm	28.0" 711mm	21.5" 546mm
400	44.0" 1118mm	30.0" 762mm	22.5" 572mm
450	44.0" 1118mm	32.0" 813mm	24.5" 622mm
500	44.0" 1118mm	34.0" 837mm	27.0" 686mm
560	44.0" 1118mm	36.5" 927mm	29.5" 749mm
630	44.0" 1118mm	39.5" 1003mm	32.0" 813mm

**QuikFit™ Carriage  
Weights**

Size	4-Jaw with Skid*	3-Jaw*
355	231.5 lbs 105 Kg	147.5 lbs 67 Kg
400	236.5 lbs 107 Kg	151.5 lbs 69 Kg
450	242.5 lbs 110 Kg	156.0 lbs 71 Kg
500	248.5 lbs 113 Kg	160.5 lbs 73 Kg
560	255.5 lbs 116 Kg	166.0 lbs 75 Kg
630	263.5 lbs 120 Kg	172.5 lbs 78 Kg

\* estimated

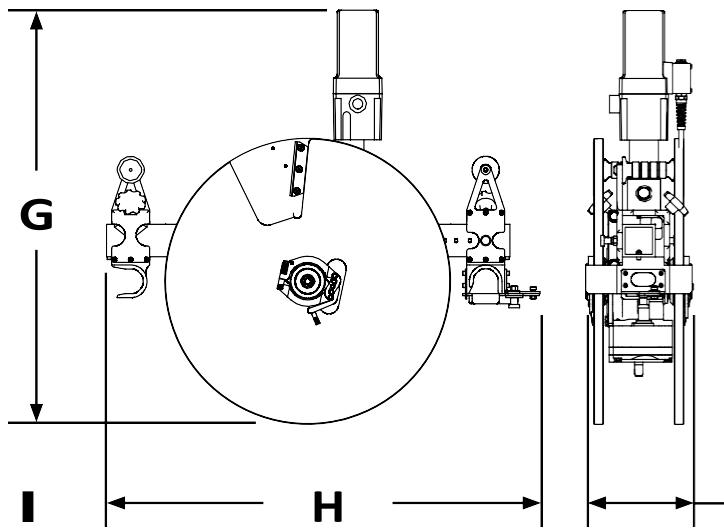

### Facer Drive Unit Dimensions

Size	G	H	I
<b>355/400</b>	33.5" 851mm	40.0" 1016mm	10.0" 254mm
<b>450/500</b>	35.5" 902mm	40.0" 1016mm	10.0" 254mm
<b>560/630</b>	38.0" 965mm	40.0" 1016mm	10.0" 254mm

### Facer Drive Unit Weights

Size	Facer Drive Unit	Facer Drive Motor	Facer Blade Holders	Total Facer Drive Unit
<b>355/400</b>	75 lbs 34 Kg	21 lbs 9.5 Kg	28 lbs 13 Kg	124 lbs 56 Kg
<b>450/500</b>	75 lbs 34 Kg	21 lbs 9.5 Kg	36 lbs 16 Kg	132 lbs 60 Kg
<b>560/630</b>	75 lbs 34 Kg	21 lbs 9.5 Kg	47 lbs 21 Kg	143 lbs 65 Kg

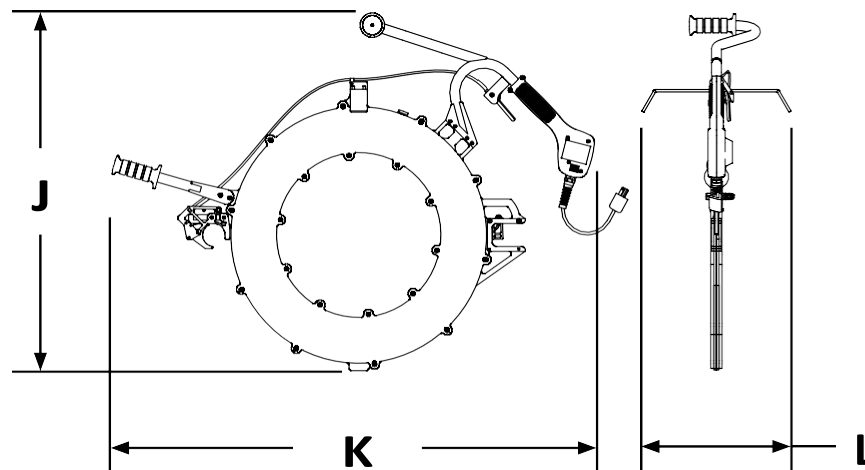

### Heater Dimensions

Size	J	K	L
<b>355/400</b>	29.0" 737mm	41.0" 1041mm	15.5" 394mm
<b>450/500</b>	32.0" 813mm	45.0" 1143mm	15.5" 394mm
<b>560/630</b>	36.5" 927mm	49.5" 1257mm	15.5" 394mm

### Heater Weights

Size	Weight*	Weight with stand*
<b>355/400</b>	29.0 lbs 13 Kg	45.5 lbs 21 Kg
<b>450/500</b>	36.0 lbs 16 Kg	57.0 lbs 26 Kg
<b>560/630</b>	48.5 lbs 22 Kg	72.0 lbs 33 Kg

\* estimated

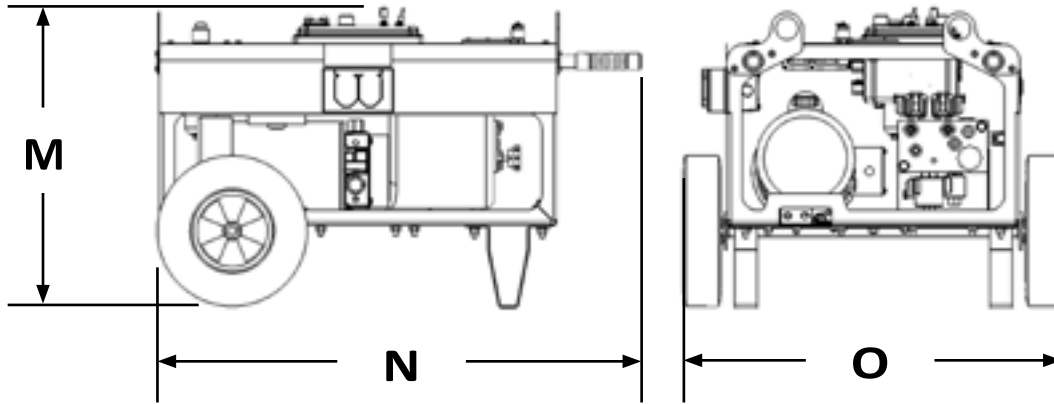

**Hydraulic Power Unit Dimensions**

	M	N	O
HPU	19.5" 495mm	32.0" 813mm	25.5" 648mm

**Hydraulic Power Unit Weight**

	Weight
HPU	170 lbs 77 Kg

**Acrobat™ 355-630mm Specifications**

- Models:** A2480101 - Acrobat™ 355mm/400mm Machine Package  
 A2480102 - Acrobat™ 450mm/500mm Machine Package  
 A2480103 - Acrobat™ 560mm/630mm Machine Package  
 A2480104 - Acrobat™ 355mm - 630mm Machine Package

**Capacity:** Fuses Pipe Sizes 355mm, 400mm, 450mm, 500mm, 560mm, 630mm

**Heater:**

- Power Requirements:** 355-400mm, 200-240V (1720W) 50/60Hz 1 Ph 7.8A  
 450-500mm, 200-240V (2496W) 50/60Hz 1 Ph 11.3A  
 560-630mm, 200-240V (3810W) 50/60Hz 1 Ph 17.3A

**Plug Type:** NEMA 6-20

**Facer:**

- Power Requirements:** 230V (1700W) 50/60Hz 1 Ph 7.4A  
**Plug Type:** NEMA 6-20  
**Gearbox Fluid Capacity:** 24 fluid ounces (710 ml)

**Hydraulic Power Unit:**

- Power Requirements:** 2Hp 240V 50/60Hz 1 Ph 20A  
**System Pressure:** 2800 PSI  
**Plug Type:** NEMA L6-30  
**Receptacle Type:** 2 - NEMA 6-30  
**Fluid Capacity:** approximately 0.5 gallons (3.8 liters)

**Operator Provided Optional Power Adapter Specifications:**

- NEMA L6-30r to L14-30p Adapter, 250V





# GENERATOR SIZING FORM

---

---

## Generator Sizing Form

Complete this form and provide a copy to your generator supplier. This information will enable your generator supplier to correctly size a generator for your application.

---

Pump Motor: \_\_\_\_\_ hp

Pump Motor Voltage: \_\_\_\_\_

Pump Motor Phases: \_\_\_\_\_

Pump Motor Frequency: \_\_\_\_\_ (50 or 60 Hz)

---

Facer Motor: \_\_\_\_\_

Facer Motor Voltage: \_\_\_\_\_

Facer Motor Phases: \_\_\_\_\_

Facer Motor Frequency: \_\_\_\_\_ (50 or 60 Hz)

---

Heater Wattage Rating: \_\_\_\_\_ Watts resistive

Heater Voltage: \_\_\_\_\_

---

Operational Altitude Range: \_\_\_\_\_ to \_\_\_\_\_

Ambient Temperature Range: \_\_\_\_\_ to \_\_\_\_\_

Duty Cycle: Standby (Not continuous 24 hours/day)

Allowable Voltage Dip: 15%

Allowable Frequency Dip: 5%

Starting Load Application: Simultaneous turn-on of pump motor and heater.

Running Load: Motor cycling on and off at varied intervals, heater cycling on and off at varied intervals, facer continuous.

Fuel: \_\_\_\_\_ (Gasoline or Diesel)

Special requirements for customer application: \_\_\_\_\_

---

---

---

---

---

---

---

---

## **Equipment Rental**

### **Rental Equipment Manager**

781-388-4618

[toolmanager@asahi-america.com](mailto:toolmanager@asahi-america.com)

### **Rental Administration, Billing & Returns**

781-388-4623

[toolrental@asahi-america.com](mailto:toolrental@asahi-america.com)

## **Field Technician/Onsite Training**

### **Field Training**

800-343-3618

[info@asahi-america.com](mailto:info@asahi-america.com)

## **Technical Service**

### **High Purity, Double Wall or Industrial Piping**

781-321-5409

[pipe@asahi-america.com](mailto:pipe@asahi-america.com)

## **Asahi/America Corporate Headquarters**

### **Asahi/America, Inc.**

655 Andover St.

Lawrence, MA 01843

800-343-3618

[asahi@asahi-america.com](mailto:asahi@asahi-america.com)



Tel: 781-321-5409 • Fax: 800-787-6861 • Toll Free: 800-343-3618  
[www.asahi-america.com](http://www.asahi-america.com) • [asahi@asahi-america.com](mailto:asahi@asahi-america.com)  
Direct Sales: East: 800-232-7244 / Central: 800-442-7244 / West: 800-282-7244