

FOR REFERENCE ONLY
ASAHI/AMERICA

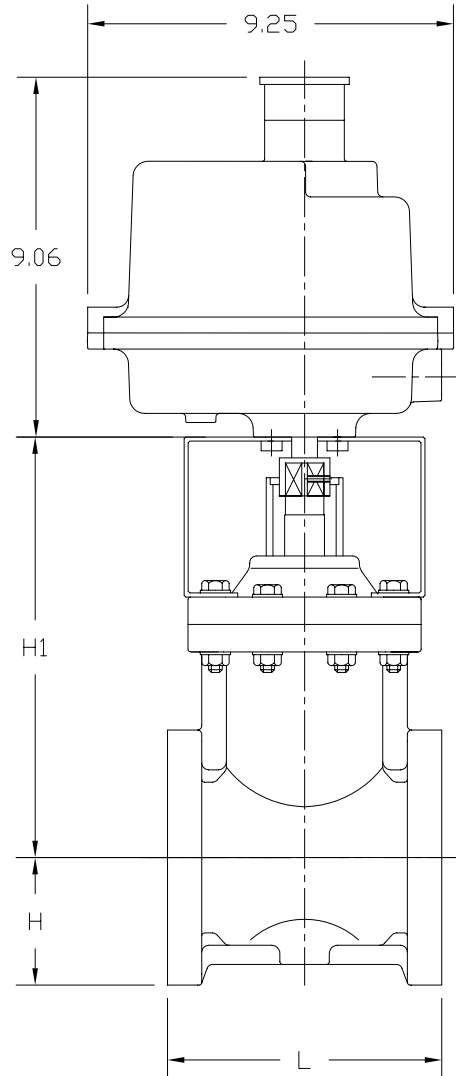

UNIT: INCH

| VALVE SIZE | 1-1/2" | 2" | 3" |
|------------|--------|-------|-------|
| H | 2.50 | 3.00 | 3.75 |
| H1 | 9.00 | 10.46 | 14.06 |
| L | 6.50 | 7.01 | 7.99 |

NOTE. The shape and appearance of assembly differ a little with nominal size compared to this drawing.

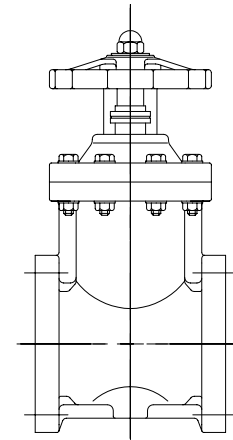

ORIGINAL GATE VALVE

| 7 | BOLT (M8.0x1.25-16LG) | STAINLESS STEEL 303 | 4 |
|------|-----------------------|-----------------------|-----|
| 6 | FLAT WASHER (M8.0) | STAINLESS STEEL 303 | 4 |
| 5 | SET SCREW | STAINLESS STEEL 303 | 1 |
| 4 | COUPLING | STAINLESS STEEL 303 | 1 |
| 3 | MOUNTING BRACKET | STAINLESS STEEL 303 | 1 |
| 2 | ACTUATOR SERIES 92 | POWER COATED ALUMINUM | 1 |
| 1 | GATE VALVE | PVC | 1 |
| ITEM | DESCRIPTION | MATERIAL | QTY |

THIS DRAWING AND ALL INFORMATION HEREON IS THE PROPERTY OF ASAHI/AMERICA. ANY COPYING, REPRODUCTION OR UNAUTHORIZED USE IS FORBIDDEN WITHOUT WRITTEN CONSENT.

| | NAME | DATE |
|---------|------------------|---------|
| DR | KENICHI MIYAZAKI | 10/1/01 |
| APPD | DAVE HURLEY | 10/1/01 |
| PROD | LED LESTER | 10/1/01 |
| WO#/SO# | | |
| FILE | | |

ASAHI/AMERICA

ISO 9001 CERTIFIED

35 GREEN STREET, P.O. BOX 653, MALDEN, MA.



GATE VALVE
SERIES 92 ELECTRIC ACTUATOR
1-1/2" THRU. 3"

| | | | | | |
|-------|-----|----------|--------------|-----|---|
| SIZE | A | DWG. NO. | 0015GT | REV | A |
| SCALE | NTS | | SHEET 1 OF 1 | | |