**SERVICE INSTRUCTIONS
MODEL 630-HRT
AUTOMATIC ASAHI DIAPHRAGM VALVE
Size 3"-6" Type 14 and Type 15
WITH 2117 WESTLOCK LIMIT SWITCH**

TABLE OF CONTENTS

GENERAL	2
INSTALLATION	2
OPERATING	3
MAINTENANCE	3 & 4
DRAWING	5

ASAHI/AMERICA

**TELEPHONE: 781-321-5409
FAX: 781-321-4421
<http://www.asahi-america.com>**

**35 Green St
Malden, MA 02148**

MODEL 630-HRT AUTOMATIC DIAPHRAGM VALVE WITH LIMIT SWITCH AND LIMIT STOP

REF: DRAWING NO. 148573

GENERAL:

The model 630-HRT is an operated valve with an Asahi diaphragm valve body and is normally closed air to open. The actuator is equipped with 2217 limit switch.

INSTALLATION:

Mount the valve in the line carrying the medium to be controlled. Flow can be in either direction and there are no restrictions as to the position of the valve - either vertical or horizontal.

Care should be taken when tightening the flange bolts so as to avoid cracking the flanges. If the valve body has female screwed ends, make sure that the pipes are in line and free from strain. The threaded ends of the pipes should be treated with a good grade of pipe joint compound.

Connect the "opening air" supply line to the 1/4" NPT female pipe connection on the side of the lower diaphragm case. This air line should carry air at a pressure as shown on the data plate attached to the valve bonnet.

LIMIT SWITCH:

When making electrical connections to the limit switch - note that if it is desirable, the switch assembly bracket can be rotated to a more convenient position by loosening the hold-down nut where the bracket mounts on the post.

Make sure that the closing and opening air pressures are turned on and that the pressure is correct. The unit is ready for operational service.

For operating and maintenance instructions, see the following pages.

OPERATING:

Assuming that all instructions under “INSTALLATION” have been followed and that all air pressures and other services have been turned on, the unit is ready.

START-UP:

If the valve does not fully open when air pressure is applied to the actuator, check to see that the correct opening air pressure is being applied. See the data plate attached to the valve bonnet.

Also, check the solenoid valve or other device in the air supply line to be sure that it is functioning properly.

If the valve does not fully close when air pressure is vented from the actuator, check to see that the solenoid valve or other device in the air supply line is functioning properly and that all the air pressure is actually being vented.

It is advisable prior to start-up to open all the valves and flush out the lines to remove any sediment or foreign matter which may become trapped in the valve body and prevent proper closing.

MAINTENANCE:

Provided that the unit has been properly specified as to body material, lining, body diaphragm, etc., very little maintenance is required.

It may be necessary to periodically replace the actuator diaphragm;

REPLACING THE ACTUATOR DIAPHRAGM:

- (1) Remove the weather-cap from the top of the unit and make a note of the distance, which the adjusting screw protrudes above the spring case.
- (2) Back off the adjusting screw until it is just finger tight. Then loosen and remove all the Allen cap screws around the base of the spring case and lift off the spring case and springs.
- (3) Loosen and remove the nuts from the rim-bolts around the outer rim of the actuator and lift off the upper diaphragm case.
- (4) Loosen and remove the diaphragm nut at the center of the diaphragm- lift off the upper plate and the old diaphragm.
- (5) Place the new diaphragm, plate and nut on to the threaded end of the push rod and tighten the nut with a wrench - being careful to see that the rim holes in the diaphragm match those in the lower diaphragm case.

(6) Now insert the rim bolts - upwards through the lower diaphragm case and diaphragm. Now install the upper diaphragm case, turn on the rim-bolt nuts, and tighten them with a wrench - evenly all around - as tight as possible.

(7) Set the spring in place over the nut in the center of the plate, carefully lower the spring case on to the pad provided, install and tighten the hold down screws and then turn down the adjusting screw to the dimension previously noted in step (1) above. Replace the weather-cap and the unit is ready for operation.

REPLACING THE VALVE BODY DIAPHRAGM:

(1) Vent air pressure from the actuator, remove the weather-cap, make a note of the distance the adjusting screw protrudes from above the top of the spring case, and then back off the adjusting screw until it is just finger-tight.

(2) Remove the bonnet nuts, lift the bonnet and actuator assembly from the valve body and unscrew the old diaphragm. Screw in the new diaphragm - just hand tight - if at this time the holes do not match those in the bonnet - DO NOT force it further around - rather back up until the holes match up.

(3) Now mount the assembly on to the valve body and install the bonnet nuts just FINGER TIGHT. With a wrench, tighten down the adjusting screw to the dimension previously noted in step (1) above. Proceed to pull down on the bonnet nuts until the edge of the diaphragm assumes a slightly curved contour. Replace the weather-cap and the unit is ready for operation.

6-A-5HRT-2217-PI

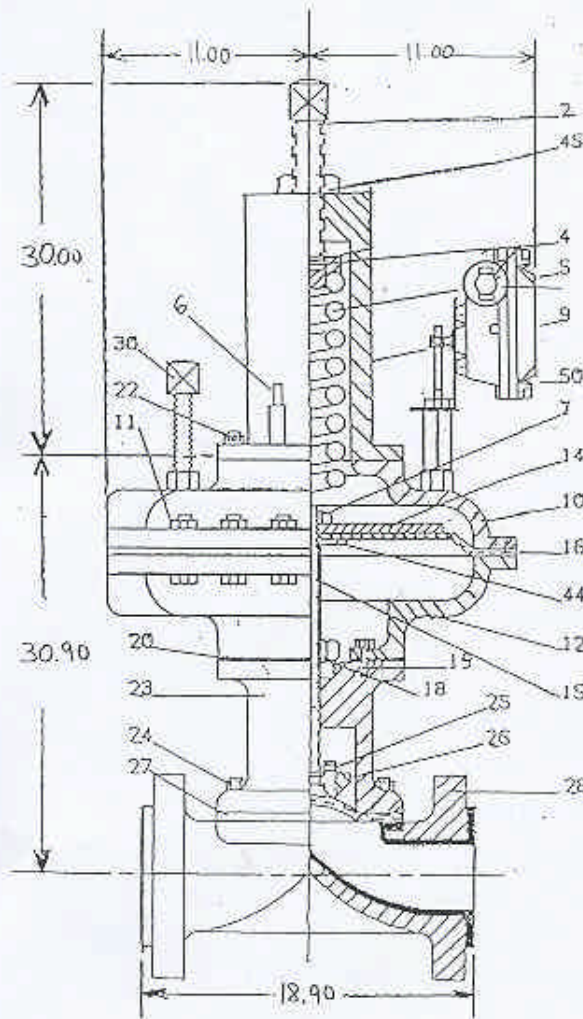

ITEM	DESCRIPTION
2	ADJUSTING SCREW
3	THRUST BEARING
4	SPRING RETAINER
5	SPRING
6	POSITION INDICATOR
7	DIAPHRAGM NUT
9	SPRING CASE
10	UPPER DIAPHRAGM CASE
11	NUT & BOLT
12	LOWER DIAPHRAGM CASE
14	DIAPHRAGM PLATE
15	PUSH ROD
16	OPERATOR DIAPHRAGM
18	INTERNAL SEAL ASSEMBLY
19	ALLEN CAP SCREW
20	BONNET GASKET
22	ALLEN CAP SCREW
23	BONNET
24	BONNET NUT
25	COMPRESSOR PIN
26	COMPRESSOR
27	TEFLON/EPDM DIAPHRAGM
28	PVC FLANGED BODY
30	DOUBLE UPPER STOPS
45	LOCK NUT
50	WESTLOCK 2217 SWITCH

* RECOMMENED SPARE PARTS
WHEN ORDERING PARTS, SPECIFY SERIAL NUMBER.

CERTIFIED BY: _____
DATE: _____

BY: AS	DATE: 4-Sep-03	CENTURY INSTRUMENT CO: LIVONIA, MICHIGAN 48150
SCALE: NONE	DWG. NO. 148573	REFERENCE: CENTURY 630HRT DIAPHRAGM CONTROL VALVE AIR TO OPEN SPRING TO CLOSE