

Pneumatic Globe Control Valve

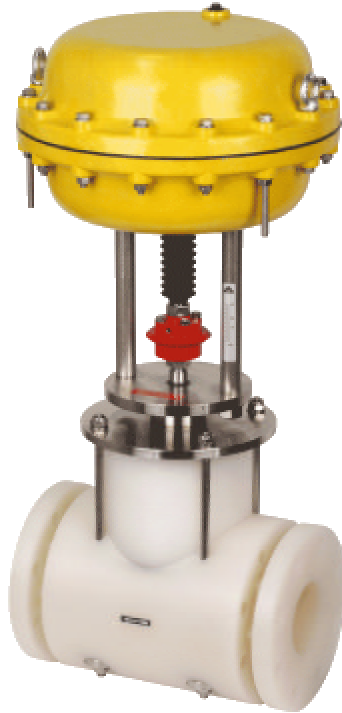

Installation, Operation and Maintenance Manual



USER INFORMATION

Table of Contents

Pneumatic Globe Control Valve Introduction	3
Description.....	3
Air Requirement.....	3
Installation	3
Isolation Valves.....	3
System Flushing.....	3
Flow Direction.....	3
Orientation.....	3
Flanges.....	4
Air Connections.....	4
Operation	4
Single Acting:.....	4
Double Acting:.....	4
Optional Accessories.....	5
Pneumatic Positioner (3-15 psi).....	5
Electro-Pneumatic Positioner (4-20 mA).....	5
Position Transmitter.....	5
Dry Contact Switches.....	5
Maintenance	5
Instructions for Trim Set Replacement (Plug and Seat).....	5
Replacement parts to keep on hand:.....	6
Engineering Data	7
Troubleshooting.....	8

Pneumatic Globe Control Valve Introduction

Description

The Pneumatic Globe Control Valve utilizes a linear diaphragm actuator constructed of Glass-filled Polyester. This actuator has a BUNA-N diaphragm, Stainless Steel trim, and ¼" FNPT air connection(s). Actuator is available as air to air, air to spring fail open, or air to spring fail close.

A molded (PVC or PP) or machined (PVDF or PTFE) body and trim set is mounted to the actuator at the factory for a complete valve/actuation package. Valve is offered in sizes ½" – 4" ANSI flanged.

Air Requirement

The condition and quality of the compressed air supply to an actuator will affect the efficiency and the life of the seals, diaphragm, and actuator.

Clean, instrument quality dry air or gas is recommended for satisfactory operation. Lubricated air is acceptable, but is not necessary.

If air lubricators are used, the lubricant selected must be compatible with actuator internals!

Installation

Isolation Valves

Manual isolation valves should be installed on the upstream AND downstream side of the control valve to control system pressure, and to assist in the installation or removal of the control valve.

System Flushing

It is recommended by Asahi America, Inc. that the piping system be completely flushed prior to valve installation. This action will eliminate potential damage to the valve due to loose debris in the piping system.

Flow Direction

Be sure to install valve so that system flow direction matches flow direction as indicated on valve body.

Orientation

If orientation is other than vertical, valve/actuator assembly **MUST** be supported to eliminate side-loading of components.

Flanges

Pipeline flanges must be properly aligned, parallel, and square to pipeline for proper installation. Flat face flanges are recommended as well as low torque gaskets, such as Asahi America AV gaskets. See torque chart below.

Asahi/America, Inc. AV Gasket Torque in inch/pounds

Size	EPDM	EPDM/PVDF	EPDM/PTFE
1/2"	157	174	174
3/4"	157	174	174
1"	157	174	174
1 1/4"	165	191	191
1 1/2"	174	217	217
2"	174	217	217
2 1/2"	217	304	304
3"	217	304	304
4"	217	304	304

Air Connections

A PTFE thread sealant should be used when installing the air line(s) to the 1/4" FNPT air inlet connector. This also applies to the positioner (if supplied). Maximum air pressure should not be exceeded; see serial number tag for allowable maximum pressure.

Operation

Single and Double Acting:

Pressurized air is introduced to the chamber and displaces a diaphragm which is direct coupled to the valve stem. When the diaphragm is displaced, it raises upward raising the valve stem, which opens the valve. This action is the same for single acting and double acting actuators.

Single Acting:

When the pressurized air is removed, the compressed springs located at the opposite side of the diaphragm relax. As the springs relax, they in turn lower the valve stem, which closes the valve. Although the term "relax" is used, the springs are NEVER relaxed, and are ALWAYS under tension, so caution must be exercised.

Double Acting:

When the pressurized air is removed, the unit remains in the same position until pressurized air is applied to the opposite port (unlike the single acting actuator).

Optional Accessories

Pneumatic Positioner (3-15 psi)

An SRI981 Pneumatic positioner can be supplied with the unit, completely mounted and calibrated. This will allow for precise flow control via a variable 3-15 psi instrument signal AND a constant supply pressure (see serial number tag for maximum pressure allowed).

Electro-Pneumatic Positioner (4-20 mA)

An SRI986 Electro-Pneumatic positioner can be also supplied with the unit, completely mounted and calibrated. This will allow for precise flow control via a variable 4-20 mA instrument signal AND a constant supply pressure (see serial number tag for maximum pressure allowed).

Position Transmitter

An SMI983 Position Transmitter can be installed and calibrated inside of the positioner housing.. This will provide a variable 4-20 mA transmission of position back to a PLC/DCS.

Dry Contact Switches

A set of double extra limit switches can be installed and calibrated inside of the positioner housing.. This will provide a contact closure report of end position back to a PLC/DCS.

Maintenance

The Pneumatic Globe Control Valve does not need any preventative maintenance.

Periodic checks should be performed to ensure proper operation and tightness of all fasteners.

Instructions for Trim Set Replacement (Plug and Seat)

Asahi America Globe Control Valves can be disassembled by using standard tools. Removal of the valve seat requires a spanner wrench, while removal of the valve plug can be achieved with a strap wrench.

Important: If you are replacing the trim set, we recommend replacing all of the seals, the flange gaskets, and the PTFE bellows.

Disassembly

Reference page 7 for assembly and disassembly

CAUTION: Isolate the actuator from instrument signal and compressed air supply (or electrical supply) before ANY type of maintenance is performed. Also make sure that the air is bled from the pneumatic actuator.

Remove the four bolts from the position indicator (#7), the two nuts from the actuator standoffs (#6), and lift off actuator from body. Remove bellows housing (#9) by removing bellows housing bolts. Remove plug (#14) from bellows (#11) by unthreading CCW, and install new plug onto bellows by threading CW. Next remove seat (#13) from valve body (#15) using a spanner wrench and unthreading CCW, then install new seat by threading CW.

NOTE: If valve is failsafe to close, be sure to remove some of the plug to seat tension.

Assembly:

Re-install bellows housing with bellows housing bolts and tighten. Re-install actuator to valve, then tighten actuator standoffs and position indicator hardware. Re-check all mounting hardware and tighten if necessary. Pressure test and calibrate unit before installing into pipeline

Valve Installation:

Install tested and calibrated valve assembly with new A/V Gaskets following guidelines on pages 3 & 4.

Replacement parts to keep on hand:

- 1 pc of PTFE bellows #11
- 1 set of O-Ring seals #8, #10, & #12
- 1 plug #14
- 1 seat #13
- 1 set of AV Gaskets
- 1 diaphragm #3 (for pneumatic actuator)

When ordering replacement parts, it is imperative that the serial number be provided to us.

Engineering Data

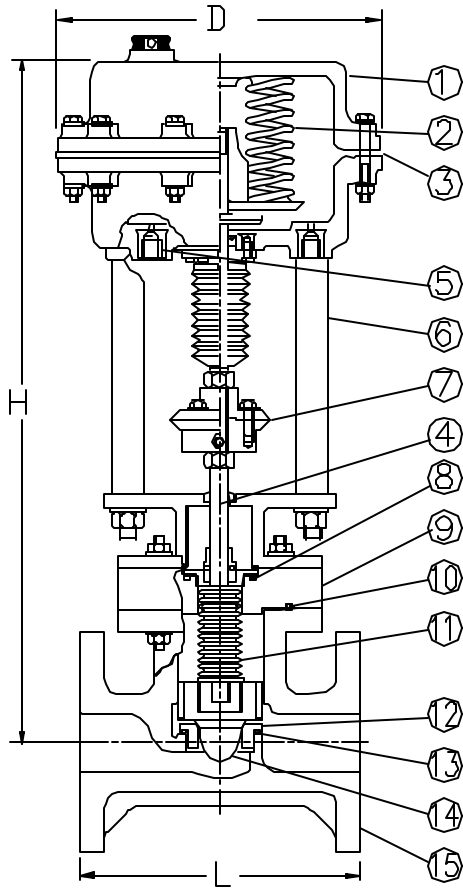

NOMINAL SIZE		PVC, PP			PVDF, PTFE		
inches	mm	L	H	D	L	H	D
1/2	15	3.35	16.54	8.66	5.12	17.71	8.66
3/4	20	3.74	16.54	8.66	5.91	17.91	8.66
1	25	4.33	16.73	8.66	6.30	17.91	8.66
1 1/4	32	5.31	16.93	8.66	7.09	18.11	8.66
1 1/2	40	7.48	17.13	8.66	7.87	18.31	8.66
2	50	7.87	18.51	8.66	9.06	18.50	8.66
2 1/2	65	8.66	18.70	8.66	11.42	18.70	8.66
3	80	9.45	20.08	8.66	12.20	19.88	8.66
4	100	11.42	20.28	8.66	13.78	20.37	8.66

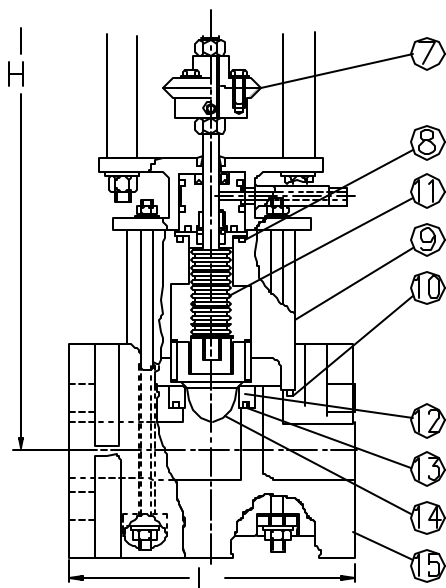
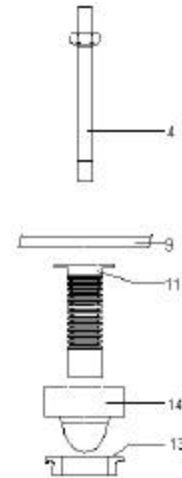

Parts List (Sizes 1 1/2"-4")

PARTS			
NO	DESCRIPTION	PCS.	MATERIAL
1	Pneumatic Actuator	1	PEG
2	Actuator Springs	1	Coated Steel
3	Diaphragm	1	BUNA N (Nitrile)
4	Actuator Valve Stem	1	316 Stainless Steel
5	Air Connection	1	1/4" FNPT
6	Actuator Standoffs	2	316 Stainless Steel
7	Position Indicator	1	Nylon coated steel
8	Bellows Seal O-Ring	1	EPDM, FKM, PTFE Encapsulated FKM
9	Bellows Housing	1	PVC, PP, PVDF, PTFE
10	Body O-Ring	1	EPDM, FKM, PTFE Encapsulated FKM
11	Bellows	1	PTFE
12	Seat O-Ring	1	EPDM, FKM, PTFE Encapsulated FKM
13	Valve Seat	1	PVC, PP, PVDF, PTFE
14	Valve Plug	1	PVC, PP, PVDF, PTFE
15	Valve Body	1	PVC, PP, PVDF, PTFE

Cv VALUES FOR PVC and PP

SEAT DIA (INCHES)	VALVE SIZE (INCHES)								
	1/2"	3/4"	1"	1 1/4"	1 1/2"	2"	2 1/2"	3"	4"
.106	.23								
.149	.46								
.185	.70								
.236	1.20								
.299	1.75	1.75							
.374	2.60	2.60	2.6						
.404		4.00	4.0	4.0					
.578		6.10	6.1	6.1	6.1				
.748				9.5	9.5	9.5			
.944				10.5	10.5	10.5	10.5		
1.181					16.0	16.0	16.0	16.0	
1.496						25.0	25.0	25.0	25.0
1.909							40.0	40.0	40.0
2.047							46.0	46.0	46.0
2.244								64.0	64.0
2.696									81.0
2.897									93.0

Cv VALUES FOR PVDF and PTFE

SEAT DIA (INCHES)	VALVE SIZE (INCHES)								
	1/2"	3/4"	1"	1 1/4"	1 1/2"	2"	2 1/2"	3"	4"
.106	.23								
.149	.46								
.185	.70								
.236	1.20								
.299	1.75	1.75							
.374	2.60	2.60	2.6						
.404		4.00	4.0	4.0					
.578		6.10	6.1	6.1	6.1				
.748				10.5	10.5	10.5	10.5		
.944					14.0	14.0	14.0	14.0	
1.181					18.0	18.0	18.0	18.0	18.0
1.496						29.0	29.0	29.0	29.0
1.909							40.0	40.0	40.0
2.047								52.0	52.0
2.244									70.0
2.696									93.0
2.897									105.0

Troubleshooting

Q: What if fluid flows even when closed?

A: Plug and or seat damaged. Replace.

It is recommended to replace ALL of the spare parts listed on page 6 if valve is disassembled for repair.

A: Foreign matter caught or formed at plug and seat. Inspect and repair if necessary.

It is recommended to replace ALL of the spare parts listed on page 6 if valve is disassembled for repair.

A: Air not completely exhausted from actuator and or positioner.

Q: What if valve does not open?

A: Actuator diaphragm is damaged or worn. Replace.

A: Supply air pressure is low. Check for proper air pressure.

A: Improper signal pressure. Check for proper signal pressure.

A: Positioner output not connected to actuator input. Check connection.

Q: What if fluid leaks from body?

A: Bolts for bellows housing and body are loose. Tighten.

A: O-rings chemically attacked. Check chemical compatibility of o-ring material versus media and operating temperature.