

Series 92 Actuator For A/C Modulating Service



Installation, Operation and Maintenance Manual



Table of Contents

DHC-100 Introduction	3
FEATURES.....	3
Series 92 Electric Actuator Introduction	4
Description	4
Electrical Requirement	4
Installation.....	5
Electrical.....	5
Type 21 Ball Valve	6
Type 23 Ball Valve (3-way)	6
Type 57 / 57L Butterfly Valves	6
Actuator Mounting Dimensions.....	7
Operation	8
Manual Override Operation	8
Setting Limit Switches	8
Calibration	9
Outline Diagram.....	9
QuickCal Procedure	10
Aux Open/Close Option Setup.....	11
Aux Position Option Setup	11
Power / Signal (J2).....	12
Actuator (J1)	12
Override (J7).....	12
Mode	13
Adjust up and Adjust down.....	13
Override Mode	13
Auto.....	14
Manual/FB Pot Cal	15
Close	15
Open.....	15
Auxiliary Close Output.....	16
Auxiliary Open Output	16
Command Type.....	16
Loss of Command.....	17
Auxiliary Position Out Cal.....	17
Fault Indicator.....	18
Stall Detection.....	19
Electronic Brake.....	19
Duty Cycle Control.....	19
Option Modules	20
Series 92 Options Codes for Serial # Tags.....	21
Specifications	21
DHC-100 Specs.....	21
Series 92 Specs.....	22
Troubleshooting.....	23

Maintenance26
 Spare Parts26

DHC-100 Introduction

The DHC-100 is a high performance digital positioner intended to control AC actuators, providing 450 points of resolution with quarter turn actuators ranging from 2 sec to 120 sec and rated for 25% duty or more. The DHC-100 has many automatic advanced features that will enhance any actuator while making it easy to install and set up.

The simple three button control is used to configure all parameters the unit needs for a wide variety of applications, and allows the *open* and *closed* positions to be easily set for direct or reversing acting without any rewiring. The unit can be configured for various command types (4-20mA, 1-5V, 0-5V, 0-10V, or a digital command) and its default operation upon loss of command.

Various option modules are easily plugged into the unit, providing other features such as a position feedback signal (current or voltage), auxiliary switches, fault relay contact, or digital communications. A wide range of data is accessible through a digital communications module, providing additional control or information.

The unit is of single solid construction and is easily mounted with two screws. The DHC-100 is interchangeable with the AMC and LRC standard size controllers, and can be used to upgrade performance for those applications.

FEATURES

- Positions to $\pm 0.1^\circ$ with quarter-turn actuators ranging from 2 sec to 90 sec.
- Three button control provides easy setup and eliminates the need for instrumentation.
- **Polarity Detection** feature allows direct or reverse acting operation without re-wiring.
- **Electronic Brake** feature can eliminate need for a mechanical brake in many applications, and extends mechanical brake life when used.
- **Stall Detection** feature protects actuator motor from a stall condition.
- Automatic **Duty Cycle Control** feature prevents shutdown of a process due to a thermal overload of the actuator motor, and allows actuators rated for 25% duty or more to be safely used.
- Operating temperature range of 0 to 60°

Series 92 Electric Actuator Introduction

Description

The Series 92 electric actuators feature a reversing, capacitor run motor, with a permanently lubricated gear train, and hardened steel spur gears. These actuators are equipped with integral thermal overload protection (AC models) with automatic reset, independently adjustable limit switches, declutchable manual override, beacon position indication, baked powder coating with stainless steel trim, ISO bolt circle, and 2 (two) ½" NPT conduit entries.

Standard models are offered in 115 VAC, feature a combination enclosure of Nema-4X, 7 & 9, and, provide up to 2000 in-lbs. of output torque.

The DHC-100 is easily mounted with 2 screws and is equipped with removable screw terminals that provide for easy field wiring. The unit's size, mounting, and screw terminals are compatible with the AMC-100, AMC-101 and LRC-101 series controllers - the DHC-100 can be used as a direct replacement for those units in nearly any application.

A simple three button control allows the user to perform a complete set-up from the unit itself without the need for any instrumentation. The adaptive control feature of the DHC-100 eliminates the need for any calibration steps. In the simplest application, only the *closed* and *open* positions need to be set and the unit automatically and continuously sets all other parameters when placed in the AUTO mode.

CAUTION: These units are intended to be mounted in an appropriate enclosure to avoid electrical shocks. High voltages are present on the outside of the unit when power is applied. AC power should be disconnected prior to any wiring of these units. A heater and thermostat should be used where condensation may occur.

Electrical Requirement

CAUTION: Proper voltage must be supplied to actuator/positioner package or the result could be a damaged positioner, a damaged actuator, or both.

NOTE: To conform to various electrical codes, a green grounding screw has been installed (on the baseplate) inside of actuator.

The DHC-100 is rated for motors with up to 5A running currents and comes in three versions to accommodate different voltage applications. The DHC-100 is rated for 117 VAC $\pm 10\%$; the DHC-100A is rated for 234 VAC $\pm 10\%$, and the DHC-100B is rated for 24 VAC $\pm 10\%$.



Installation

Electrical

Reference Drawing #289S92

Models S-92, A92, & B92

1A. To gain access to terminal strip (Part #24) it is necessary to remove manual override knob (Part #18) by loosening slotted setscrew (Part #39). Remove 2 cover screws and cover; the remaining 6 cover screws are packaged inside the actuator.

Model C92

1B. To gain access to terminal strip it is necessary to remove manual override hand wheel (Part #18A) by loosening slotted setscrew (Part #39). Remove cam (Part #51) by loosening 2 set screws (Part #52). Remove 2 cover screws and cover; the remaining 6 cover screws are packaged inside the actuator.

All Models

2. Make electrical connections to terminal strip as shown on wiring schematic located inside the cover (per various electrical codes there is a green screw on the actuator base plate for grounding purposes). All units are completely calibrated prior to shipment, and no internal adjustments should be required.
3. Install 1/2" NPT conduit fitting(s) to actuator base. Please ensure that proper conduit fitting is used to maintain enclosure rating (weatherproof, explosion proof or combination weather proof/explosion proof).

NOTE: We recommend sealing conduit openings on units installed outdoors or exposed to large temperature swings (15°F or more).

We also recommend the heater and thermostat option in these applications.

4. Replace actuator (gasket if removed) cover, and install 8 cap screws supplied and tighten securely. For outdoor or wet locations it is recommended prior to replacing the cover that the top shaft seal be cleaned and coated with silicone grease. Also clean shaft and lightly coat seal area of shaft with silicone grease. Unit is now ready for operation.

Model	Torque (in/lbs)	115 Vac		230 Vac		12 Vdc		24 Vdc		12 Vac		24 Vac		Cycle Time per 90 Degrees (seconds)
		Amp Draw	Duty Cycle	Amp Draw	Duty Cycle	Amp Draw	Duty Cycle	Amp Draw	Duty Cycle	Amp Draw	Duty Cycle	Amp Draw	Duty Cycle	
S92	400	0.5	100%	0.4	100%	2.0	75%	4.0	75%	2.0	75%	3.0	75%	10
A92	700	0.8	75%	0.6	75%	2.0	75%	4.0	75%	2.0	75%	3.0	75%	10
B92	1100	0.5	100%	0.4	100%	2.0	75%	4.0	75%	2.0	75%	3.0	75%	25
C92	2000	1.0	50%	0.6	50%	2.0	75%	4.0	75%	2.0	75%	3.0	75%	25

NOTE: Amp rating is considered locked rotor.
Duty cycles are for ambient temperature (73°F)

Type 21 Ball Valve

Position the valve and the actuator to corresponding positions (either OPEN or CLOSED). The flats on the actuator shaft extension indicate valve position

Type 21 Ball Valves (See Drawing #0107BV sizes ½" – 2")

Install mounting bracket #3 to actuator #2 using bolts #8 and washers #9. Insert coupling #4 on stem of valve #1 and then bolt valve #1 to mounting bracket #3 using bolts #5, nuts #7, and washers #6.

Note: All bolts should be snug and not excessively over tightened.

Type 21 Ball Valves (See Drawing #0113BV sizes 2-1/2" - 4")

Install mounting bracket #3 to actuator #2 using bolts #8 and washers #9. Insert coupling #4 on stem of valve #1 and then bolt valve #1 to mounting bracket #3 using bolts #5, nuts #7, and washers #6.

Note: All bolts should be snug and not excessively over tightened.

Type 23 Ball Valve (3-way)

Position the valve and the actuator to corresponding positions (either OPEN or CLOSED). The flats on the actuator shaft extension indicate valve position

Type 23 Ball Valves (3-way): (See Drawing #0130BV, sizes ½" - 4")

Install mounting bracket #3 to actuator #2 using bolts #8 and washers #9. Insert coupling #4 on stem of valve #1 and then bolt valve #1 to mounting bracket #3 using bolts #5, nuts #7, and washers #6.

Type 57 / 57L Butterfly Valves

CAUTION: If valve is in line, system must be shut down and have no line pressure before removing throttle plate and retaining washer.

Position the valve and the actuator to corresponding positions (either OPEN or CLOSED). The flats on the actuator shaft extension indicate valve position

Butterfly Valves (See Drawing # 0200BF57 sizes 1-1/2" - 6")

No specially machined stem or valve body drilling required. Remove handle (remove handle cap and hex head bolt) to expose throttle plate screws. Remove throttle plate and retaining washer to expose existing bolt pattern.

Mount bracket #3 to actuator #2 with bolts #8 and washers #9 and tighten evenly. Insert coupling #4 into actuator #2. Install valve #1 onto mounting bracket #3 and align stem of valve to engage with coupling. (Line scribed on top of stem

indicates disc orientation). Install bolts #5, washers #6 and nuts #7 and tighten evenly. Flats on actuator shaft indicate valve position. (Disc Orientation)

Butterfly Valves (See Drawing #0168BF57 8" size)

No specially machined stem or valve body drilling required. Remove gear operator by removing 4 thru bolts in body of valve to gear operator and lift off. Mount bracket #2 to actuator #10 using bolts #7 and washers #8. Insert actuator shaft adapter #9 into actuator #10. Install valve #1 to mounting bracket #2 and align stem of valve to engage with coupling. (Line scribed on top of stem indicates disc orientation). Install bolts #3, washers #4 & #5 and nuts #6 and tighten evenly. Flats on actuator shaft indicate valve position. (Disc Orientation)



CAUTION: If mounted unit is installed other than straight up, the actuator should be supported independently to prevent side loading and loosening up of fasteners.

Actuator Mounting Dimensions

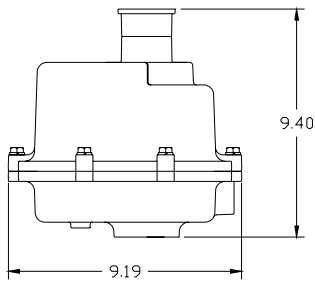

S92, A92, & B92

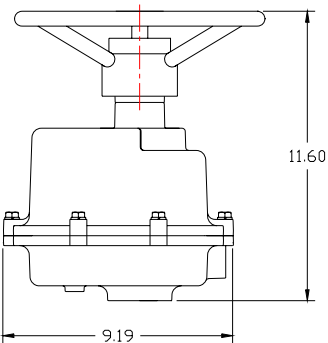
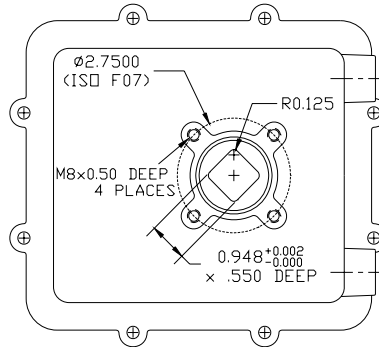
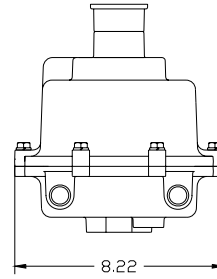

C92

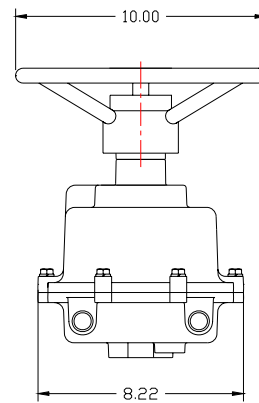

Operation

Manual Override Operation Reference Drawing #289S92

Models S-92, A92, & B92

Pull up the declutching knob (Part #18) and apply a 5/8" open end wrench to exposed flats and rotate within labeled limits as indicated by arrows.

To re-engage simply rotate actuator shaft in the opposite direction until declutching knob drops back down into position.

Model C92

Push down on hand wheel (Part #18A) and rotate within labeled limits.

To re-engage simply rotate actuator hand wheel until it moves up and re-engages.

CAUTION: The manual override should only be used when there is no power applied to actuator. When power is restored the actuator will automatically resume normal operation.

Setting Limit Switches Reference Drawing #289S92



Disconnect power!

Open Travel Limit Switch (Top Switch Part #25):

Using declutchable manual override, move the valve approximately 2 degrees beyond the full open position. Then loosen set screws on top cam (Part #40) and rotate cam (CCW) into limit switch arm until a click is heard, this designates the switch circuit has opened and defines a full open position. Tighten 2 set screws (Part #40) on cam.

Close Travel Limit Switch (Bottom Switch Part #25):

Using declutchable manual override, move the valve approximately 2 degrees beyond the full closed position, loosen set screws on bottom cam (Part #40) and rotate cam (CW) into limit switch arm until a click is heard, this designates the switch circuit has opened and defines a full closed position. Tighten 2 set screws (Part #40) on cam.

Manually position valve to midstroke. Reapply power to actuator and drive to open or closed position. Actuator motor will run. The shaft will not turn until drive pins (Part #7) reseat in drive gear. This could take up to 25 seconds.

CAUTION: The limit switches inside of the unit are for loss of signal conditions; NOT for normal operation of the modulating actuator.

Calibration

Outline Diagram

DHC-100 117VAC
 DHC-100A 234VAC
 DHC-100B 24VAC

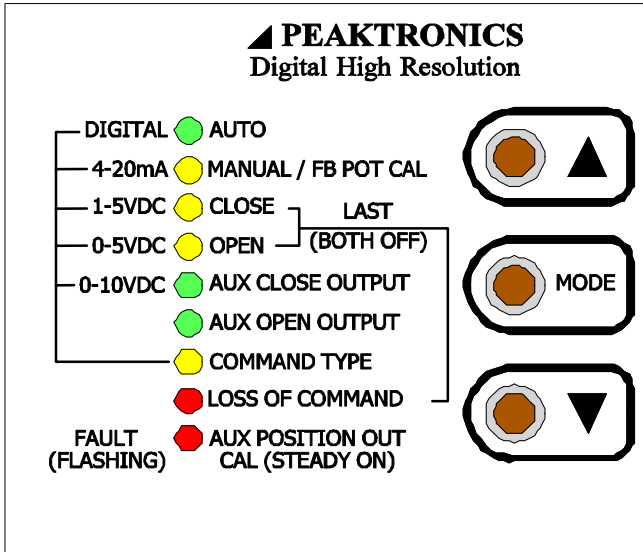

FRONT PANEL

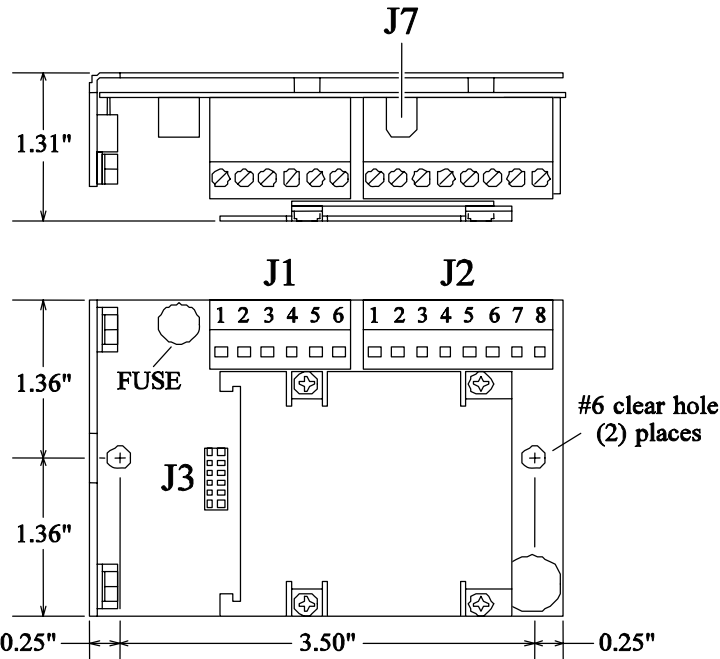

ELECTRICAL CONNECTIONS

J1

to Motor	
MOTOR 1 OUTPUT	1
NEUTRAL	2
MOTOR 2 OUTPUT	3
GND	4
WIPER	5
+2.5V	6
to Feedback Pot	

J2

to AC Power	
L2 NEUTRAL	1
L1 LINE	2
EARTH GND	3
SIGNAL GND (-)	4
4-20mA (+)	5
1-5V, 0-5V, 0-10V (+)	6
+5V OUT	7
+15V OUT	8
to Signal	

J3
OPTION MODULE CONNECTOR

J7

to Auto/Manual Station	
GND	1
OVERRIDE INPUT	2

QuickCal Procedure

The following is a quick calibration procedure. For more details regarding the calibration and features of your DHC-100, please see the pages following this procedure.

General

The MODE button selects a particular function, or mode, and the indicator for the selected mode turns on steady. Pushing the MODE button saves any new setting of the current mode before switching to the next mode. The adjust up (▲) and adjust down (▼) buttons are used to make adjustments to current mode.

1. Apply power to the actuator on Connector J2: terminal #1 (neutral), terminal #2 (line), and terminal #3 (earth). There is no need for a signal connection during calibration.
2. Push the MODE button until the yellow “MANUAL/FB POT CAL” LED is illuminated. The LED may be flashing (at different speeds) through the next several steps. This is expected and will be explained.
3. Use the adjust buttons (▲ and ▼) to move the actuator and verify that the limit switches are set past the desired open and closed positions; then move the actuator to mid stroke.
4. If LED is solid, proceed to step 7.
5. If LED is flashing, loosen the gear on the actuator shaft and rotate the potentiometer gear until the LED is no longer flashing, but on solid - this indicates the center of the potentiometer’s travel. Note that the LED will flash at a slower rate the farther away from the mid position it gets. Once the LED is on solid tighten all gears.
6. Push the MODE button until the “CLOSE” LED is illuminated. Use the adjust buttons (▲ and ▼) to drive the actuator to the desired closed position. Ensure that the close limit switch does not engage.
7. Push the MODE button until the “OPEN” LED is illuminated. Use the adjust buttons (▲ and ▼) to drive the actuator to the desired open position. Ensure that the open limit switch does not engage.
8. Please skip to **Aux Open/Close Setup** if optional Transmitter with Relays is installed; otherwise continue to the next step.
9. Push the MODE button until the “COMMAND TYPE” LED is illuminated. Use the adjust buttons (▲ and ▼) to select appropriate input signal (4-20mA, 1-

5VDC, 0-5VDC, 0-10VDC, or Digital). If 0-5VDC or 0-10VDC is selected, the LOSS OF COMMAND feature is not available, so proceed to step 12.

10. Push the MODE button until the "LOSS OF COMMAND" LED is illuminated; this sets the actuator to a predetermined position upon loss of command. Use the adjust buttons (▲ and ▼) to select appropriate position (OPEN, CLOSE, or LAST POSITION).
11. Please skip to **Aux Position Setup** if optional Transmitter, or optional Transmitter with Switches is installed, otherwise continue to the next step.
12. Push the MODE button until the "AUTO" LED is illuminated. Your calibration is now **COMPLETE**. Connect the command signal wires to connector J2: terminal #4 (signal ground) and terminal #5 (mA input) **OR** terminal #6 (voltage input), depending on the application. If a signal input was already connected, the actuator should have moved to that position.

Aux Open/Close Option Setup

1. Push the MODE button until the "AUX CLOSE OUTPUT" LED is illuminated. Use the adjust buttons (▲ and ▼) to drive the actuator to the desired auxiliary close position.
2. Push the MODE button until the "AUX OPEN OUTPUT" LED is on. Use the adjust buttons (▲ and ▼) to drive the actuator to the desired auxiliary open position.
3. Continue with Step 9 in the **Quick Calibration Procedure** (see above).

Aux Position Option Setup

1. Push the MODE button until the red "AUX POSITION OUT CAL" LED illuminates **while** the "CLOSE" LED flashes. Note that the red LED flashes to indicate a "Fault" and turns on steady to indicate the "AUX POSITION OUT CAL" modes.
2. Use the adjust buttons (▲ and ▼) to set the desired output voltage or current (mA) on the option module output for the closed position.
3. Push the MODE button so the "AUX POSITION OUT CAL" LED remains steady **while** the "OPEN" LED flashes. Use the adjust buttons (▲ and ▼) to set the desired output voltage or current (mA) on the option module output for the open position.
4. Continue with Step 12 in the **Quick Calibration Procedure** (see above).

Please read the following pages to ensure that ALL of the selectable features are understood and selected if required.

Power / Signal (J2)

Power is connected to pins 1, 2, and 3 as shown in the block diagram. The fuse installed on the unit is rated for maximum output current that can be safely delivered by the AC outputs. Replacement fuses must not exceed the maximum rating to prevent damage to the unit.

An appropriate command signal, either 0-5V, 0-10V, 1-5V, or 4-20mA, should be connected to pin 5 or 6 (as shown in the Block Diagram) while using pin 4 as the return *signal ground*. The DHC-100 must be configured for the type of command signal that is to be used (see COMMAND TYPE).

Pin 7 of J2 provides an auxiliary +5V output which can be used to connect a command potentiometer. By connecting one end of a potentiometer to pin 7, the other end to pin 4, and the wiper to pin 6, a local control knob can be implemented. Pin 8 provides an auxiliary +15VDC output which can be used to power an input or output 4-20mA transmitter.

Actuator (J1)

The actuator motor and feedback potentiometer are connected to J1 as shown in the Block Diagram. The Motor Neutral wire must be connected to pin 2, while one motor winding is connected to pin 1 and the other winding to pin 3. The feedback potentiometer wiper must be connected to pin 5, while one end is connected to pin 4 and the other end to pin 6. The **Polarity Detection** feature of the DHC-100 automatically determines which motor winding to control based on where the *open* and *closed* positions are set; this feature also eliminates the need to rewire the unit for direct or reverse acting applications.

When the ▲ and ▼ buttons are used to control the actuator, the ▲ button will turn on the motor winding connected to pin 1, while the ▼ button will turn on the motor winding connected to pin 3. See MANUAL/FB POT CAL for more details.

Override (J7)

J7 provides a simple 2-wire connection that can override the DHC-100 to perform a variety of external control functions. Using an appropriate interface module, commonly used auto/manual station switches are easily implemented with low voltage/low current switches. The factory-installed jumper between pins 1 and 2

enables normal operation of the DHC-100 and must be installed if the external override functions are not used.

Mode

The MODE button is used to select the desired function of operation. When the MODE button is pressed, the unit will switch to the next function and the appropriate LED indicator will turn on to let the user know which function is selected. Except for the MANUAL/FB POT CAL mode, the associated mode indicator will be steady on; for some of the modes other indicators will flash to indicate specific settings associated with the mode. Each of the modes are described in more detail in the following sections.

If a 0-5V or 0-10V command signal is used, the LOSS OF COMMAND function cannot be used. The MODE button will skip over the LOSS OF COMMAND mode when the unit is configured for a 0-5V or 0-10V command signal (see COMMAND TYPE). When the OVERRIDE mode is enabled (see OVERRIDE MODE), the MODE button is disabled and the Manual/Pot Cal indicator will turn on steady.

Adjust up and Adjust down

The adjust up ▲ and adjust down ▼ buttons are used to adjust the setting of any given function. When a function is selected by the MODE button, the adjust buttons will affect that function only. Note, that the AUTO mode does not have any adjustable settings, and therefore, the adjust up and adjust down buttons have no effect. Also, the adjust buttons are disabled in the OVERRIDE mode.

Override Mode

The OVERRIDE mode is not selected by the MODE button and can be enabled at anytime by connecting a resistance greater than 250 ohms to the Override Input (J7 pin 1 and pin 2). While the OVERRIDE mode is enabled, the MODE button and adjust buttons are disabled, and the Manual/Pot Cal indicator will turn on steady to indicate that the unit is being controlled by the Override Input. Shorting J7 pin 1 to pin 2 returns the unit to normal operation and the previously selected mode. Note that earlier models may not have connector J7, and therefore do not have the OVERRIDE mode feature.

Controlling the DHC-100 from the Override Input is accomplished by connecting a specific resistance to select a specific operation. The table below defines the operations and their associated resistance.

RESISTANCE	OPERATION
> 4.3K ohms	OFF
3.3K ohms ±5%	LATCH
2K ohms ±5%	OPEN
1.2K ohms ±5%	CLOSE
510 ohms ±5%	STOP

The OPEN function will operate the motor in the *open* direction as set by the OPEN mode, while the CLOSE function operates the motor in the *closed* direction as set by the CLOSE mode. The LATCH function will maintain the previously selected function; this allows momentary switches to be used for the OPEN and CLOSE functions. The OFF and STOP functions turn the motor off, which also unlatches the OPEN or CLOSE functions.

Note that the OPEN and CLOSE functions may work in reverse until the *open* and *closed* positions are set by the OPEN and CLOSE modes. The DHC-100 will automatically turn the motor off when the *open* or *closed* positions are reached. However, if a feedback fault occurs (see FAULT INDICATOR), the motor will be turned on for a period of 15 minutes in the selected direction. For this reason, limit switches should be used when using the OVERRIDE mode, and should be set to a position acceptable for the application. The 15 minute period can also be terminated using the OFF or STOP function.

The motor is also automatically turned off if the DHC-100 detects a stall (see STALL DETECTION). An OPEN or CLOSE operation can be attempted again after switching to the OFF, LATCH, or STOP functions first.

Auto

The AUTO function is the normal mode of operation for the DHC-100; all the other functions are used to set up the unit. While in AUTO, the unit can be controlled by various external signals, some of which can be selected by the COMMAND INPUT function. When the unit is not in the AUTO mode, all external controls described below will be disabled.

Once the *open* and *closed* positions have been set, the AUTO mode will control the position of the actuator according to the command input signal. For an input signal of 0V (for 0-5V or 0-10V input), 1V (for 1-5V input), 4.0 mA (for 4-20mA input), or 0% (for a digital input), the DHC-100 will position the actuator to the *closed* position as set by the user. Conversely, an input of 10V, 5V, 20mA, or 100% will position the actuator to the defined *open* position.

When the DHC-100 is configured to use a 0-5V, 0-10V, 1-5V, or 4-20mA command, the command signal should be connected to the appropriate pin on J2 - note that the unused input pin must be left unconnected. When the DHC-100 is configured for a Digital command type, an appropriate communications option module must be installed. A communications module may be installed when using one of the analog command types and can be used to override the analog

command. The AUTO indicator will flash whenever the unit is being controlled by the communications module.

Manual/FB Pot Cal

The MANUAL/FB POT CAL function allows manual operation of the actuator by using the adjust buttons (▲ and ▼) without affecting any other settings within the DHC-100. When the ▲ button is pressed, the motor winding connected to J1-1 is turned on while the ▼ button turns on the J1-3 winding. Whether the actuator moves toward the *open* or *closed* position depends on which motor winding is connected to J1-1 and J1-3.

The POT CAL feature provides an indication of the feedback potentiometer's setting. When the MANUAL/POT CAL function is selected, the Manual/Pot Cal indicator will turn on - it may flash or be on steady, depending on the actuator position. The indicator will be on steady whenever the DHC-100 detects that the feedback potentiometer is at midrange of its rotation. As the actuator moves, causing the feedback potentiometer to move away from midrange, the indicator will begin to flash, and the indicator will flash at a decreasingly slower rate as the actuator moves further away from midrange.

By using the adjust buttons to position the actuator to midstroke (half way point between the desired *open* and *closed* positions), the feedback potentiometer can then be adjusted until a steady light occurs. This insures that the feedback potentiometer has maximum range to reach the *open* and *closed* positions.

Close

The CLOSE function is used to set the desired *closed* position; however, prior to doing this, the feedback potentiometer should be checked for optimum position (see MANUAL/POT CAL), and the limit switches should be set outside of the operating range (see STALL DETECTION FEATURE). In the CLOSE function, the adjust buttons are used to set the actuator to any desired position, and upon pressing the MODE button (to select the next function, OPEN), the DHC-100 will retain the setting as the defined *closed* position.

Upon selecting the CLOSE function, the DHC-100 will begin moving the actuator to the previously set *closed* position; it is not necessary to make an adjustment if the unit has been previously set to the desired position. A command signal input of 0V, 1V, 4mA, or 0% automatically corresponds to the defined *closed* position.

Open

The OPEN function works the same way as the CLOSE function with the exception that the adjust buttons are used to set the desired *open* position. As

with the CLOSE function, upon selecting the OPEN function, the actuator will move to the previously set *open* position. Once the desired position is set, the DHC-100 will automatically correspond a command signal input of 10V, 5V, 20mA, or 100% to the *open* position.

Auxiliary Close Output

The AUX CLOSE OUTPUT function is used to set an optional output setting that is associated with the *closed* position - an appropriate relay option module is required to use this output. The adjust buttons are used to set the actuator to a desired position. Whenever the actuator position falls between the defined *closed* position and the Aux Close position, the Aux Close Output indicator will flash. Additionally, the DHC-100 will turn on a relay output on the optional relay module - the output can be used to drive an alarm or merely act as an auxiliary limit switch. Relay is rated for 1 amp @ 24VDC or .5 amp @ 115VAC.

Upon selecting the AUX CLOSE OUTPUT function, the DHC-100 will begin moving the actuator to the previously set position. It is not necessary to make an adjustment if the unit has been previously set to the desired position.

Auxiliary Open Output

The AUX OPEN OUTPUT function is used to set an optional output setting that is associated with the *open* position - an appropriate relay option module is required to use this output. The adjust buttons are used to set the actuator to a desired position. Whenever the actuator position falls between the defined *open* position and the Aux Open position, the Aux Open Output indicator will flash. Additionally, the DHC-100 will turn on a relay output on the optional relay module - the output can be used to drive an alarm or merely act as an auxiliary limit switch. Relay is rated for 1 amp @ 24VDC or .5 amp @ 115VAC.

Upon selecting the AUX OPEN OUTPUT function, the DHC-100 will begin moving the actuator to the previously set position. It is not necessary to make an adjustment if the unit has been previously set to the desired position.

Command Type

The COMMAND TYPE function is used to configure the command signal input for either 4-20mA, 1-5V, 0-5V, 0-10V, or digital so as to match the type of command signal being used. Upon selecting the COMMAND TYPE function, the Command Input indicator will turn on steady, while the indicator for the selected type will flash. Use the adjust buttons (▲ and ▼) to select the desired input type. The selection will be saved when the MODE button is pressed, which will also advance the unit to the LOSS OF COMMAND function.

Loss of Command

When using 1-5V, 4-20mA, or a Digital input type for the command signal, the DHC-100 will detect when the command signal is lost or out of range. A loss of command condition is detected whenever the input is disconnected, the input becomes less than 0.75V or 3mA, or the input becomes greater than 5.5V or 22mA. If the DHC-100 detects a loss of the command signal, the Fault indicator will flash and the actuator will be moved to one of three preset positions: the *open* position, the *closed* position, or the position last attained prior to losing the command signal. The LOSS OF COMMAND function is used to set the desired default position.

When the LOSS OF COMMAND function is selected, the adjust buttons ▲ and ▼ are used to set the default position. The DHC-100 indicates the selected default setting by flashing the Open function indicator for the *open* default position, or it will flash the Close function indicator for the *closed* default position. When neither indicator is on, then the "last position" default is selected.

When a 0-5V or 0-10V command signal is used, a loss of command signal cannot be detected. Therefore, if the unit is configured for a 0-5V or 0-10V command signal (see COMMAND INPUT), the MODE button will not select the LOSS OF COMMAND function.

Auxiliary Position Out Cal

Note that the AUX POSITION OUT CAL indicator also serves as a Fault indicator. When the indicator is on steady, the AUX POSITION OUT CAL function is selected. When the indicator flashes, a Fault condition has been detected (see FAULT INDICATOR for details). The AUX POSITION OUT CAL function is used to calibrate an optional feedback transmitter output. An appropriate transmitter option module is required to use this feature.

When the AUX POSITION OUT CAL function is first selected (by pressing the MODE button while in the LOSS OF COMMAND function), the CLOSE indicator will flash, and the voltage or current associated with the *closed* position will appear at the option module output. If desired, the output can be adjusted (using the adjust buttons ▲ and ▼) to any value from 0 to 10V (for a voltage output) or 0 to 20mA (for a current output). The new setting is then associated with the *closed* position.

Pressing the MODE button again will leave the unit in the AUX POSITION OUT CAL function except that the OPEN indicator will flash, and the output voltage or current associated with the *open* position will appear at the option module output. Like the *closed* setting, the output can be adjusted to any voltage (from 0 to 10V) or current (from 0 to 20mA), and the new setting is then associated with the *open* position.

Fault Indicator

The DHC-100 detects various fault conditions that prohibit the unit from controlling the actuator. When any of these conditions are detected, the Fault indicator will flash, and the motor outputs are turned off until all fault conditions have been corrected. If an appropriate relay option module is installed, the Fault relay output on the option module will also turn off. A communications option module can read the specific condition(s) causing the fault. Note that a fault condition DOES NOT disable the motor outputs when manually controlling the actuator with the adjust buttons; while useful for troubleshooting, care should be exercised when operating the motor under a fault condition. The OVERRIDE mode can also operate the motor when a fault condition exists - see OVERRIDE MODE for details. The various fault conditions are described below:

LOSS OF COMMAND - If the command signal is disconnected or out of range, the fault indicator will remain on until the signal is reconnected or back in range.

FEEDBACK POT FAULT - A fault condition is detected whenever the feedback signal is out of range (that is, less than 5% of the potentiometer value or more than 95% of the potentiometer value), or when any of the potentiometer connections are broken. Normal operation resumes when the potentiometer is reconnected or back in range.

MOTOR 1 STALL - A fault condition is detected when no actuator motion is detected while the Motor 1 output is turned on. The fault condition will disable the Motor 1 output only, and the fault is cleared when the DHC-100 detects a motion greater than 1.5° in either direction. The fault can be cleared if 1) the command signal commands a Motor 2 operation, 2) manual operation with the adjust buttons results in a motion greater than 1.5°, or 3) a mechanical manual override forces the 1.5° motion, provided the mechanical motion is monitored by the feedback pot.

MOTOR 2 STALL - A fault is detected when no actuator motion is detected while the Motor 2 output is turned on. The fault can be cleared in the same manner as a Motor 1 Stall (see above).

DOUBLE STALL - If the DHC-100 detects no actuator motion in either direction, both motor outputs will be disabled. The command signal cannot clear this condition; only manual operation or a mechanical override can clear the fault. Alternatively, the DHC-100 can be powered off and then on to temporarily clear the fault; however, this practice should be avoided without permanently correcting the cause of such a fault.

Stall Detection

The **Stall Detection** feature of the DHC-100 (see FAULT INDICATOR) essentially performs a similar function as commonly used torque switches.

The **Stall Detection** feature is useful for detecting when any of the motor wires become disconnected. However, limit switches employed in actuators essentially disconnect one of the motor windings. The DHC-100 will detect this as a motor stall. To avoid this condition, the limit switches must be set outside of the operating range set by the CLOSE and OPEN functions.

Electronic Brake

The **Electronic Brake** feature of the DHC-100 provides highly reliable and accurate braking of the motor, and it is a key element in achieving high resolution. A mechanical brake can still be implemented without interfering with the DHC-100 operation. Mechanical brakes can be useful for providing a holding brake in the event power to the actuator is lost.

Since the **Electronic Brake** feature provides the primary braking of the motor, the life of a mechanical brake is dramatically extended. Additionally, the **Adaptive Control** feature of the DHC-100 automatically compensates for changes in a mechanical brake's performance due to temperature or age.

Note that the actuator's limit switches should be set outside of the operating range set by the CLOSE and OPEN functions. The **Electronic Brake** feature degrades in performance if a limit switch is engaged. Limit switches exhibit wide variations, and the DHC-100 can position the actuator more precisely at *closed* and *open* than the limit switches. A limit switch serves better as a fail safe device to protect against electrical failures in the actuator.

Duty Cycle Control

The **Duty Cycle Control** feature of the DHC-100 allows actuators rated at 25% duty or more to be safely used in automated valve applications. The DHC-100 accurately monitors the relative heating of the motor and automatically duty cycles the unit at a safe level when a process becomes unstable, or if a control loop is not properly set. While the thermal switch in the motor protects the motor from overheating, thermal switches can shutdown the actuator for ten minutes or more.

The **Duty Cycle Control** feature allows continuous operation of the motor until it detects an excess heat build up in the motor (usually well below the limit of the thermal switch). At that time, duty cycle operation is automatically enabled and continues until the motor cools enough to resume continuous operation. The duty cycle period is approximately 2 seconds with an on time that automatically varies depending on the heating of the motor. While this operation slows down the

actuator's operation, it does not impact the resolution performance of the DHC-100, and it prevents disruption of a process due to a thermal switch shutdown.

Option Modules

Various option modules can be plugged into the DHC-100 option module connector, J3. Option modules provide additional features such as position feedback signals with auxiliary switch outputs, for example; or digital communications. Contact the factory for the latest available modules. Refer to the diagram below for instructions on installing an option module.

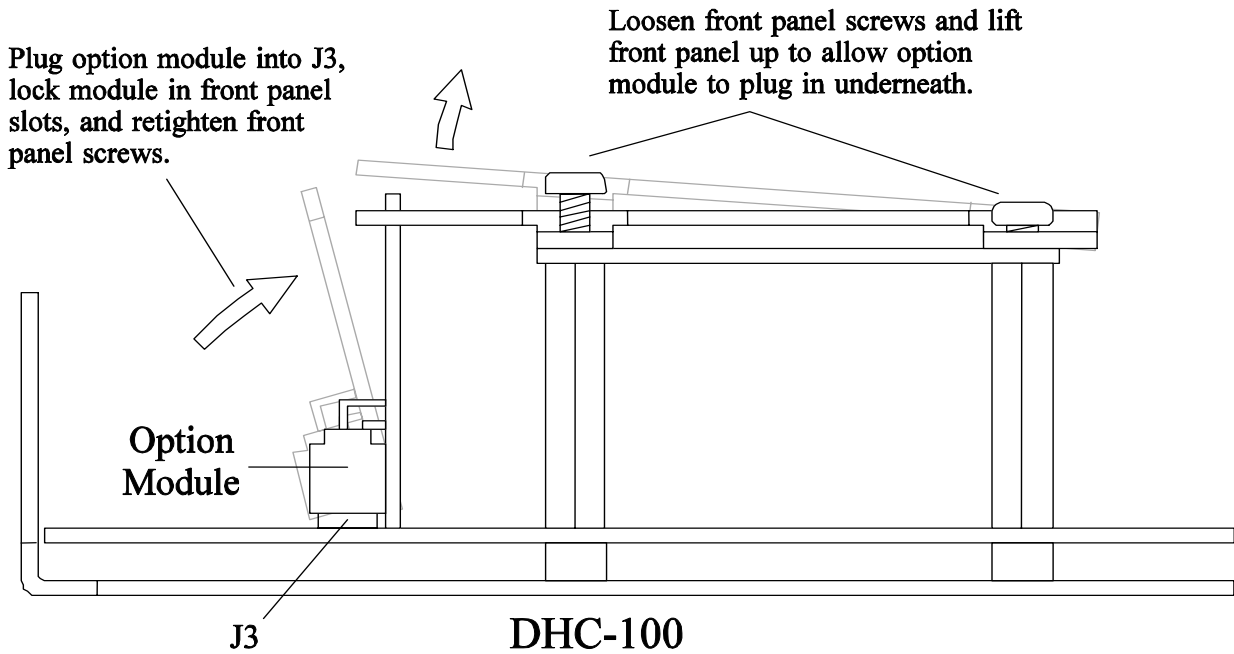

Installing an Option Module

Series 92 Options Codes for Serial # Tags

M1	1 extra limit switch
M2	2 extra limit switches
HT	Heater & thermostat
P	Feedback potentiometer
DP	Dual feedback potentiometers
C1	4-20 mA Positioner
M	Mechanical brake
CO	Center off
CLC	Cycle length control
2WC	2-wire control
FS	Failsafe Battery Pak
C3	4-20mA Output Transducer
A4	4-12mA Input Signal Positioner
B12	Split Range Positioner

Example 1: S92HTPXWJ
 Heater & thermostat and feedback potentiometer installed.

Example 2: AM92C1XWJ
 Mechanical brake and 4-20 Ma positioner installed.

Specifications

DHC-100 Specs

POWER REQUIREMENTS

DHC-100: 117VAC ±10%, 50/60 Hz
 DHC-100A: 234VAC ±10%, 50/60 Hz
 DHC-100B: 24VAC ±10%, 50/60 Hz
 12 VA typical (not including output load)
 Fuse Type: 5A TR5 Slo-Blo (replaceable)

COMMAND SIGNAL INPUT

Input Impedance
 20K ohms (1-5 VDC, 0-5 VDC, 0-10 VDC Input)
 251 ohms ±1% (4-20 mA Input)
 Loss of Command threshold
 < 0.75V or > 5.5V (1-5 VDC input)
 < 3mA or > 22mA (4-20mA input)

FEEDBACK SIGNAL INPUT

Input Voltage: 0 to 2.5 VDC
 External Feedback Potentiometer: 1K ohm

POWER SUPPLY OUTPUTS

+15V OUT (J2-8): 125mA maximum (not including option module)

+5V OUT (J2-7): 5mA maximum

NOTE: *Do not* connect these outputs to other power supplies.

AC MOTOR OUTPUTS

Off-state Leakage Current: <15mA

Maximum Load Current @ 150°C: 5A

ENVIRONMENTAL

Operating Temperature Range: 32 °F to 150 °F

Storage Temperature Range: -40 °F to 185 °F

Relative Humidity Range: 0 to 90 % (noncondensing)

Series 92 Specs

MOTOR

Brushless Capacitor Run
CE Compliant AC Motors

GEAR TRAIN

Permanently Lubricated
Rockwell Hardened

MOUNTING CONFIGURATION

ISO Bolt circle (F07)
ISO Output Drive

MANUAL OVERRIDE

Fully De-clutchable

ENCLOSURE

NEMA 4X, 7, & 9 Combination
Stainless Steel Trim
2 (Two) ½" FNPT Conduit Entries

POSITION INDICATION

Beacon Position Indicator

TEMPERATURE

150° F maximum Ambient Temperature

Troubleshooting

PROBLEM	POSSIBLE CAUSES	REMEDIES
There is no output, but the motor runs	Manual override engaged. Valve stem broken.	When the manual override is engaged, the motor will run, but no output will be observed until the manual override re-engages with the output shaft When the valve stem is broken, there will not be a change in fluid movement, making it seem as if the actuator has no output..
No response from valve/actuator	No power source to actuator No signal to actuator Power source disconnected Low or wrong power source Mechanical Brake jammed or misaligned	Check for power Check "Fault Indicator Check for broken wire, loose connection Check for proper voltage Check alignment of brake
Motor hums and no output is observed	Foreign material caught in valve Capacitor worn	Remove material and inspect valve for damaged and/or worn parts. Replace parts as necessary Replace capacitor
No response from unit (All lights are off.)	No power Excessive voltage applied to unit. Blown or missing fuse	Check power source. Replace unit. Replace with appropriate fuse; see "Specifications" in manual.

PROBLEM	POSSIBLE CAUSES	REMEDIES
No response from unit (MANUAL / FB POT CAL light is on.)	Jumper wire on J7 terminal block is missing.	Install jumper wire on J7 terminal block.
Actuator rotates backwards.	Actuator or valve is mounted incorrectly on coupling.	Remount actuator as necessary.
	Actuator needs to be reverse acting.	Refer to "Close" and "Open" modes in manual.
Actuator does not respond to input signal. (FAULT indicator constantly flashes.)	Input signal not connected	Connect input signal and refer to "Loss of Command" in manual.
	Input signal polarity reversed.	Reverse input wires.
	Input signal wired to wrong terminal.	Check input signal wiring; refer to "Power/Signal J2" in manual.
	Feedback potentiometer improperly wired.	Check wiring; refer to "Actuator J1" in manual.
	Feedback potentiometer out of range.	Refer to "Manual/FB Pot Cal" in manual.
	Defective feedback potentiometer.	Replace feedback potentiometer.
	Defective motor brake (holds motor)	Repair or replace motor brake.
	Defective motor (not turning)	Repair or replace motor.

PROBLEM	POSSIBLE CAUSES	REMEDIES
Actuator does not respond to input signal. (FAULT indicator is off.)	Closed and open positions are set to the same position.	Set closed and open settings; refer to "Close" and "Open" modes in manual.
FAULT indicator flashes after actuator reaches the fully closed or open position.	Closed or open limit switches set inside the operating range.	Adjust limit switch cams; refer to "Close" and "Open" modes in manual.
Actuator operates erratically. (FAULT indicator flashes erratically.)	<p>AC ripple induced on the command input signal.</p> <p>Defective feedback potentiometer</p> <p>Loose feedback potentiometer or loose feedback potentiometer gears</p> <p>Sloppy gear tooth engagement</p>	<p>Use equipment that isolates AC ripple from the command signal.</p> <p>Replace feedback potentiometer.</p> <p>Tighten feedback potentiometer and/or potentiometer gears.</p> <p>Adjust feedback potentiometer gears for tight engagement.</p>

Maintenance

Disconnect power!



NEVER REMOVE ACTUATOR COVER WHILE CIRCUITS ARE LIVE!

CAUTION: It is imperative for reducing the chance of electrical shock, and to prevent ignition of hazardous atmospheres that you

Disconnect power

before any maintenance or repairs are performed.

Series 92 actuators are virtually maintenance free. We do however, recommend that periodic checks are made to ensure that all fasteners are tight and properly torqued to extend the life of the actuator and valve.

Series 92 Actuators are manufactured with factory lubricated grease in the gear case and gearbox. In most cases, this lubricant should never have to be replenished, however if deemed necessary, we recommend using Aeroshell Grease #17, mfg. by Shell Oil Co.

Consult our technical department before replenishing lubricant.

For outdoor or wet locations keep top and bottom seals coated with a silicone based grease.

Spare Parts

Reference Drawing #289S92

We recommend that the following be kept on hand as spare parts.

- 1 --- Limit Switch (Part #25)
- 1 --- Capacitor (Part #27 or #28)

NOTE: When ordering replacement motor parts and/or options specify model # and voltage.

Attachments:

8 drawings: 0107BV, 0113BV, 0130BV, 0168BF57,
0200BF57, 289S92, M00EL381, M00EL382

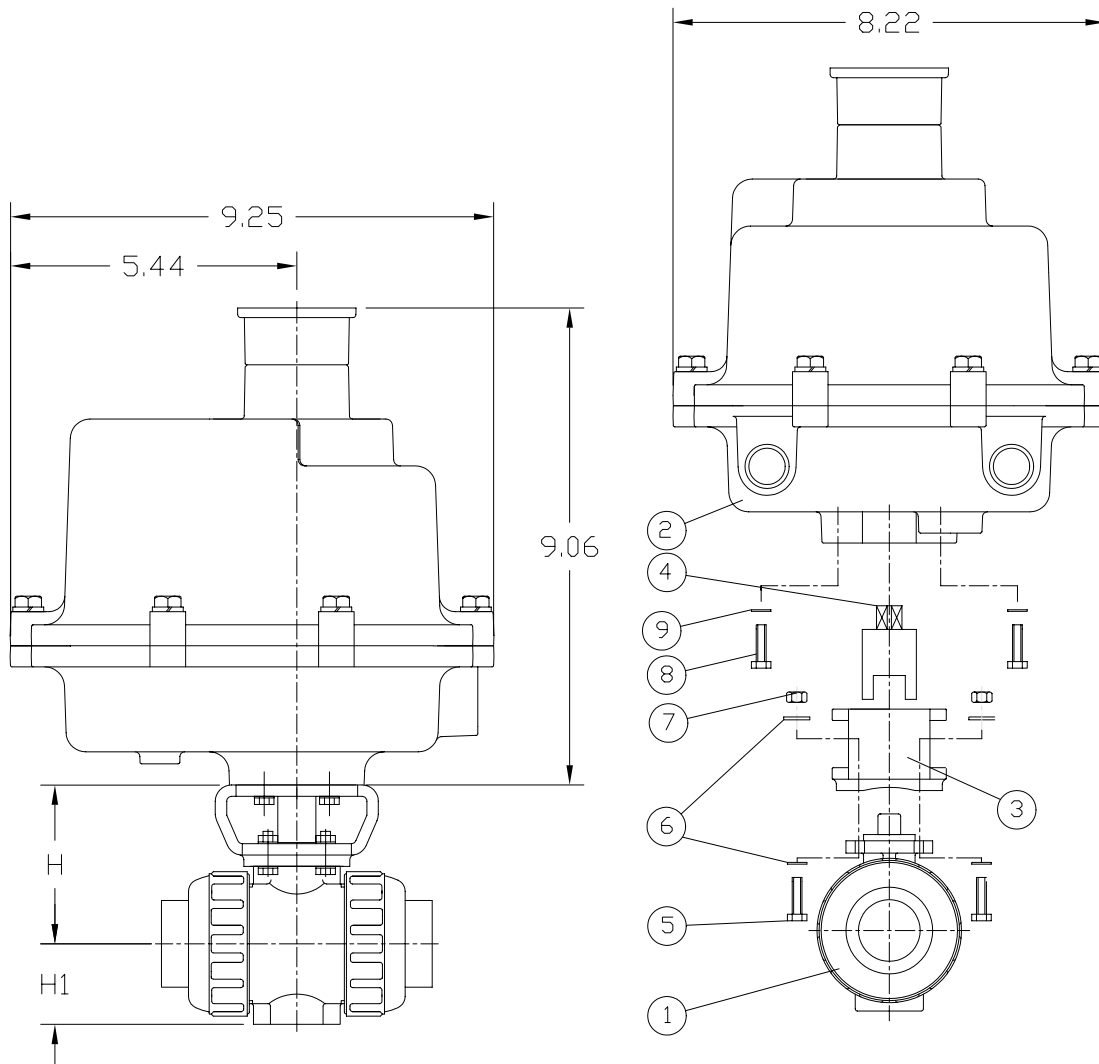

UNIT: INCH

VALVE SIZE	1/2"	3/4"	1"	1-1/4"	1-1/2"	2"
H	2.76	3.01	3.29	3.64	3.98	4.43
H1	1.14	1.38	1.54	1.85	2.17	2.60

NOTE. The shape and appearance of assembly differ a little with nominal size compared to this drawing.

9	FLAT WASHER (M8.0)	STAINLESS STEEL	4
8	BOLT (M8.0x1.25-16LG)	STAINLESS STEEL	4
7	NUT (FOR 1/2" THRU 1-1/4" : M5.0x8) (FOR 1-1/2" THRU 2" : M6.0x1)	STAINLESS STEEL	4
6	FLAT WASHER (FOR 1/2" THRU 1-1/4" : M5.0) (FOR 1-1/2" THRU 2" : M6.0)	STAINLESS STEEL	8
5	BOLT (FOR 1/2" THRU 1-1/4" : M5.0x8-16LG) (FOR 1-1/2" THRU 2" : M6.0x1-20LG)	STAINLESS STEEL	4
4	COUPLING	STAINLESS STEEL 303	1
3	MOUNTING BRACKET	PPG	1
2	ACTUATOR SERIES 92	EPOXY COATED ALUMINUM	1
1	BALL VALVE TYPE 21	PVC,CPVC,PP,PVDF	1
ITEM	DESCRIPTION	MATERIAL	QTY

FOR REFERENCE ONLY
ASAHI/AMERICA

THIS DRAWING AND ALL INFORMATION HEREON IS THE PROPERTY OF ASAHI/AMERICA. ANY COPYING, REPRODUCTION OR UNAUTHORIZED USE IS FORBIDDEN WITHOUT WRITTEN CONSENT.

	NAME	DATE
DR	DAN CAMERON	8/02/01
APPD	DAVE HURLEY	8/2/01
PROD	LED LESTER	8/2/01
WO#/CO#		
FILE		

ASAHI/AMERICA
ISO 9001 CERTIFIED
35 GREEN STREET, P.O. BOX 653, MALDEN, MA.

BALL VALVE TYPE21
SERIES92 ELECTRIC ACTUATOR
1/2" THRU 2"

SIZE	DWG. NO.	REV
A	0107BV	A

SCALE NTS SHEET 1 OF 1

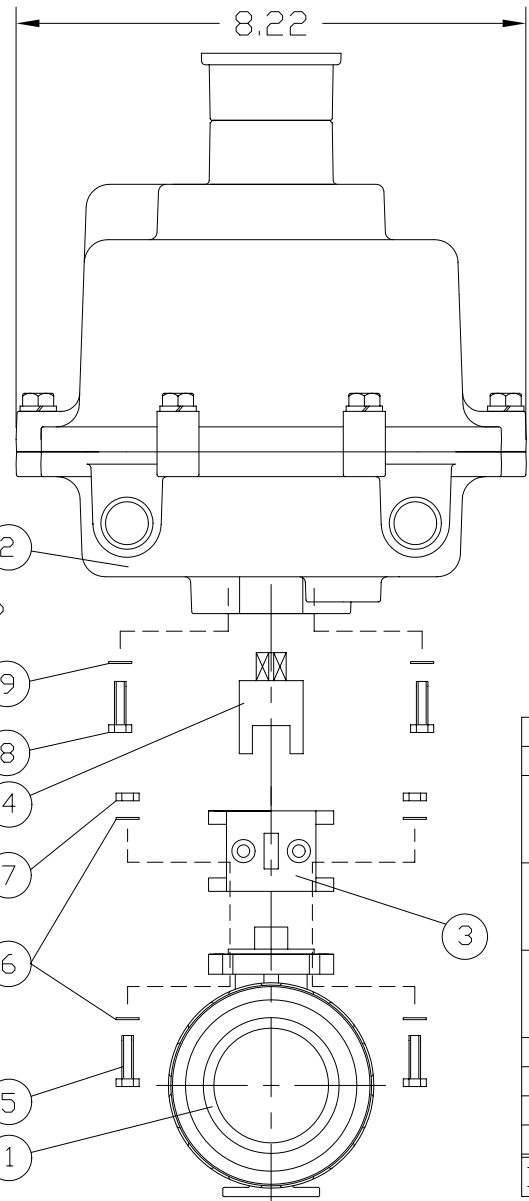
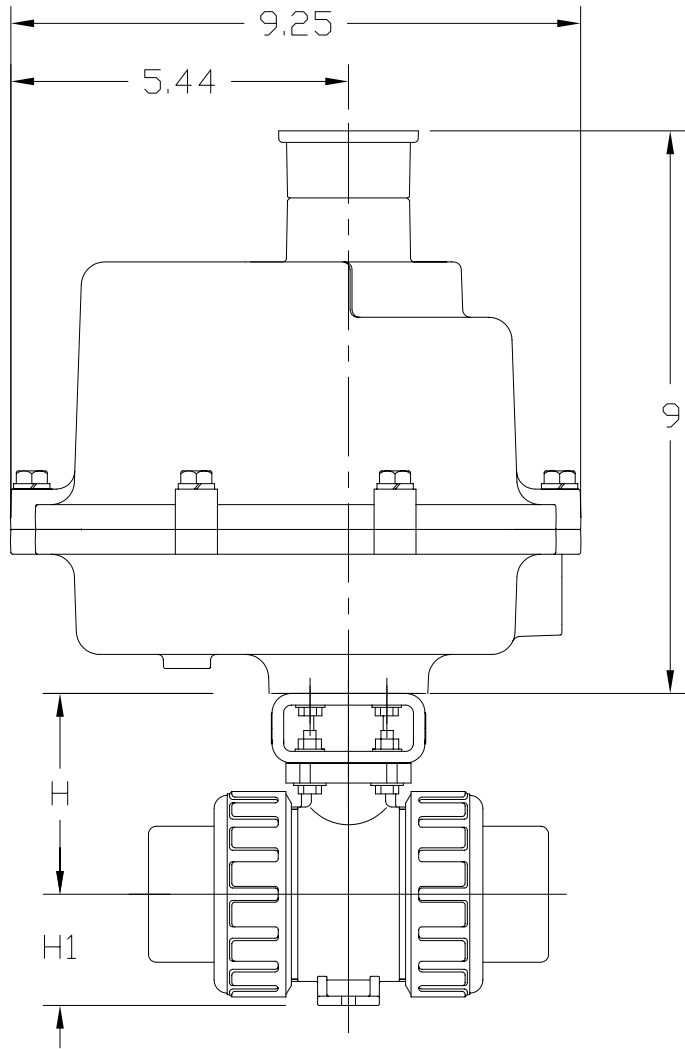

UNIT: INCH

VALVE SIZE	2-1/2"	3"	4"
H	5.12	5.47	6.97
H1	2.83	3.35	4.33

NOTE. The shape and appearance of assembly differ a little with nominal size compared to this drawing.

9	FLAT WASHER (M8.0)	STAINLESS STEEL	4
8	BOLT (M8.0x1.25-16LG)	STAINLESS STEEL	4
7	NUT (FOR 2-1/2" AND 3" : M8.0x1.25) (FOR 4" : M10.0x1.50)	STAINLESS STEEL	4
6	FLAT WASHER (FOR 2-1/2" AND 3" : M8.0) (FOR 4" : M10.0)	STAINLESS STEEL	8
5	BOLT (FOR 2-1/2" AND 3" : M8.0x1.25-35LG) (FOR 4" : M10.0x1.50-40LG)	STAINLESS STEEL	4
4	COUPLING	STAINLESS STEEL 303	1
3	MOUNTING BRACKET	PPG	1
2	ACTUATOR SERIES 92	EPOXY COATED ALUMINUM	1
1	BALL VALVE TYPE 21	PVC,CPVC,PP,PVDF	1
ITEM	DESCRIPTION	MATERIAL	QTY

**FOR REFERENCE ONLY
ASAHI/AMERICA**

THIS DRAWING AND ALL INFORMATION HEREON IS THE PROPERTY OF ASAHI/AMERICA. ANY COPYING, REPRODUCTION OR UNAUTHORIZED USE IS FORBIDDEN WITHOUT WRITTEN CONSENT.

	NAME	DATE
DR	KENICHI MIYAZAKI	8/14/01
APPD	DAVE HURLEY	8/14/01
PROD	LED LESTER	8/14/01
WO#/CO#		
FILE		

ASAHI/AMERICA

ISO 9001 CERTIFIED

35 GREEN STREET, P.O. BOX 653, MALDEN, MA.



BALL VALVE TYPE21
SERIES92 ELECTRIC ACTUATOR
2-1/2" THRU 4"

SIZE	A	DWG. NO.	0113BV	REV	A
SCALE	NTS		SHEET 1 OF 1		

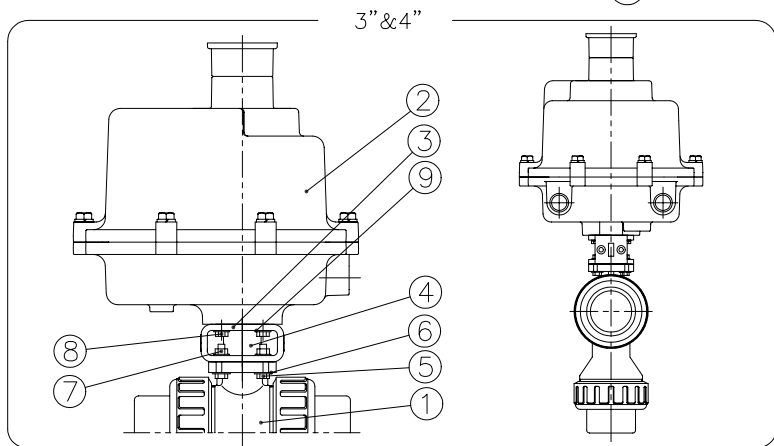
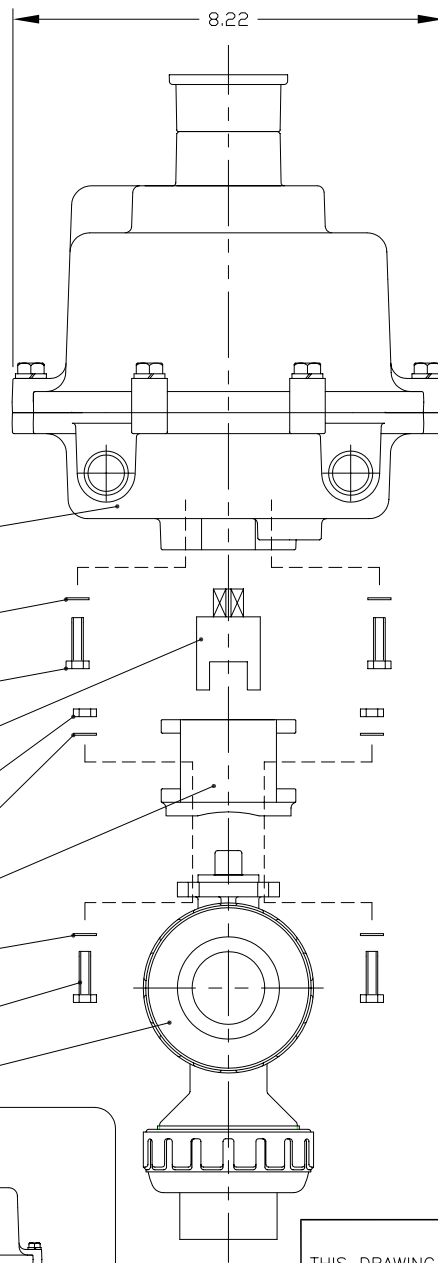
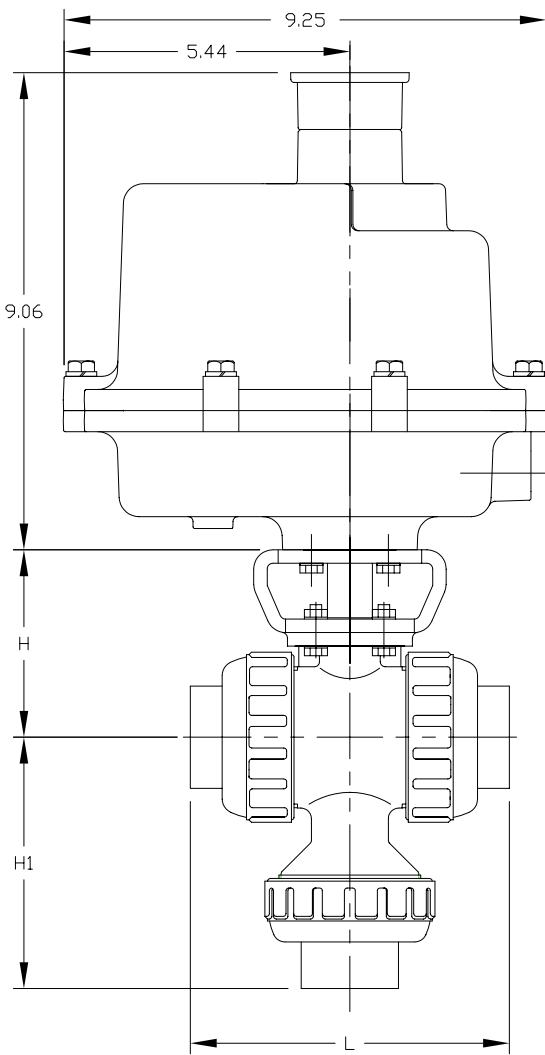

DIMENSIONS TABLE

UNIT: inch

NOMINAL SIZE	H	FLANGED		THREADED		SOCKET						SPIGOT (BUTT END)	
		H1	L	H1	L	PVC,CPVC		PP,PVDF (DIN)		PP,PVDF (IPS)		H1	L
						H1	L	H1	L	H1	L		
1/2" 15mm	2.76	3.70	5.63	2.89	4.02	3.08	4.45	2.80	3.90	3.09	4.45	3.27	4.88
3/4	3.01	4.50	6.77	3.48	4.72	3.56	5.08	3.27	4.49	3.61	5.08	3.90	5.67
1	3.29	5.24	7.36	4.13	5.16	4.32	5.75	3.94	4.84	4.37	5.75	4.53	6.06
1 1/2	3.98	6.50	8.35	5.53	6.42	5.71	7.24	5.16	5.83	5.85	7.24	6.02	6.85
2	4.43	7.34	9.21	6.61	7.76	6.66	8.23	6.06	6.93	6.76	8.23	7.01	8.82
3	5.47	10.06	11.97	9.25	10.39	9.59	11.10	8.82	9.88	11.10	11.10	9.69	11.61
4	6.97	12.01	14.65	11.77	14.17	11.58	13.90	10.98	12.20	14.37	14.37	11.85	12.72

NOTE; 1) THE SHAPE AND APPEARANCE OF ASSEMBLY DIFFER A LITTLE WITH NOMINAL SIZE COMPARED TO THIS DRAWING.

- 2) FOR DETAILED VALVE DIMENSIONS, REFER TO DWG. NO. 0126BV, 0127BV, 0128BV.
 L-PORT : DWG. NO. 0126BV
 DOUBLE L-PORT : DWG. NO. 0127BV
 CROSS PORT : DWG. NO. 0128BV

FOR REFERENCE ONLY
ASAHI/AMERICA

9	FLAT WASHER (M6.0)	STAINLESS STEEL	4
8	BOLT (M6.0x1-16LG)	STAINLESS STEEL	4
7	NUT (FOR 1/2" THRU 1-1/4" : M5.0x.8) (FOR 1-1/2" THRU 2" : M6.0x1) (FOR 3" : M8.0x1.25) (FOR 4" : M10.0x1.50)	STAINLESS STEEL	4
6	FLAT WASHER (FOR 1/2" THRU 1-1/4" : M5.0) (FOR 1-1/2" THRU 2" : M6.0) (FOR 3" : M8.0) (FOR 4" : M10.0)	STAINLESS STEEL	8
5	BOLT (FOR 1/2" THRU 1" : M5.0x.8-16LG) (FOR 1-1/2" THRU 2" : M6.0x1-20LG) (FOR 3" : M8.0x1.25-35LG) (FOR 4" : M10.0x1.50-40LG)	STAINLESS STEEL	4
4	COUPLING	STAINLESS STEEL 303	1
3	MOUNTING BRACKET	PPG	1
2	ACTUATOR SERIES 92	ZYTEL	1
1	MULTI PORT BALL VALVE TYPE23	PVC,CPVC,PP,PVDF	1
ITEM	DESCRIPTION	MATERIAL	QTY

THIS DRAWING AND ALL INFORMATION HEREON IS THE PROPERTY OF ASAHI/AMERICA. ANY COPYING, REPRODUCTION OR UNAUTHORIZED USE IS FORBIDDEN WITHOUT WRITTEN CONSENT.

	NAME	DATE
DR	KENICHI MIYAZAKI	1/28/03
APPD	DAVE HURLEY	1/28/03
PROD	LEO LESTER	1/28/03
WO#/CO#		
FILE		

ASAHI/AMERICA

ISO 9001 CERTIFIED

35 GREEN STREET, P.O. BOX 653, MALDEN, MA.



MULTI PORT BALL VALVE
 TYPE23 WITH SERIES92 ACT.
 1/2" THRU 4"

SIZE	A	DWG. NO.	0130BV	REV	A
SCALE	NTS	SHEET 1 OF 1			

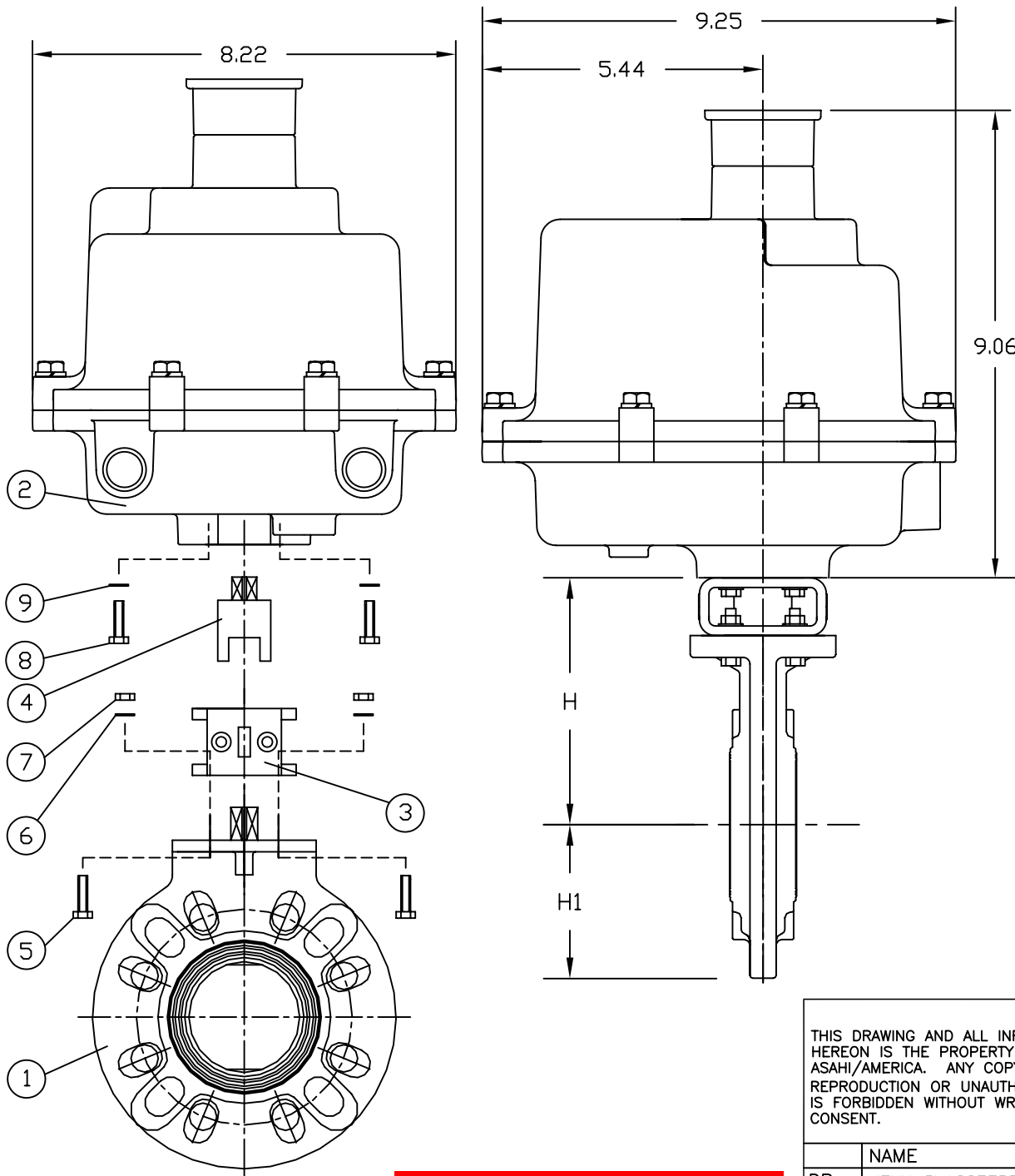

UNIT: INCH

VALVE SIZE	1-1/2"	2"	2-1/2"	3"	4"	5"	6"
H	5.51	5.75	6.18	6.46	7.16	8.46	8.97
H1	2.95	3.27	3.66	3.94	4.53	5.00	5.63

NOTE: 1.The shape and appearance of assembly differ a little with nominal size compared to this drawing.

2. For 1-1/2" thru. 4" Mounting Bracket : F7 x F05,F07
For 5" and 6" Mounting Bracket : F10 x F07,F10

9	FLAT WASHER (M8.0)	STAINLESS STEEL	4
8	BOLT (M8.0x1.25-16LG)	STAINLESS STEEL	4
7	NUT (FOR 1-1/2" THRU. 4" : M8.0x1.25) (FOR 5" AND 6" : M10.0x1.50)	STAINLESS STEEL	4
6	FLAT WASHER (FOR 1-1/2" THRU. 4" : M8.0) (FOR 5" AND 6" : M10.0)	STAINLESS STEEL	8
5	BOLT (FOR 1-1/2" THRU. 4" : M8.0x1.25-35LG) (FOR 5" AND 6" : M10.0x1.50-40LG)	STAINLESS STEEL	4
4	COUPLING	STAINLESS STEEL 303	1
3	MOUNTING BRACKET	PPG	1
2	ACTUATOR SERIES 92	EPOXY COATED ALUMINUM	1
1	BUTTERFLY VALVE TYPE 57	U-PVC,PP,PVDF	1
ITEM	DESCRIPTION	MATERIAL	QTY

THIS DRAWING AND ALL INFORMATION HEREON IS THE PROPERTY OF ASAHI/AMERICA. ANY COPYING, REPRODUCTION OR UNAUTHORIZED USE IS FORBIDDEN WITHOUT WRITTEN CONSENT.

ASAHI/AMERICA

ISO 9001 CERTIFIED

35 GREEN STREET, P.O. BOX 653, MALDEN, MA.



BUTTERFLY VALVE TYPE57
SERIES92 ELECTRIC ACTUATOR
1-1/2" THRU 6"

	NAME	DATE
DR	JOHN GLASSFORD	6/13/05
APPD	DAVE HURLEY	6/13/05
PROD	LED LESTER	6/13/05
WO#/CO#		
FILE		

SIZE A DWG. NO. 0200BF57 REV A

SCALE NTS SHEET 1 OF 1

FOR REFERENCE ONLY
ASAHI/AMERICA

VALVE SIZE	H1	C
1 1/2'	3.74	5.00
2'	3.86	5.00
2 1/2'	3.66	5.58
3'	3.94	5.78
4'	4.53	6.56
5'	5.00	8.05
6'	5.63	8.76
8'	6.70	11.25

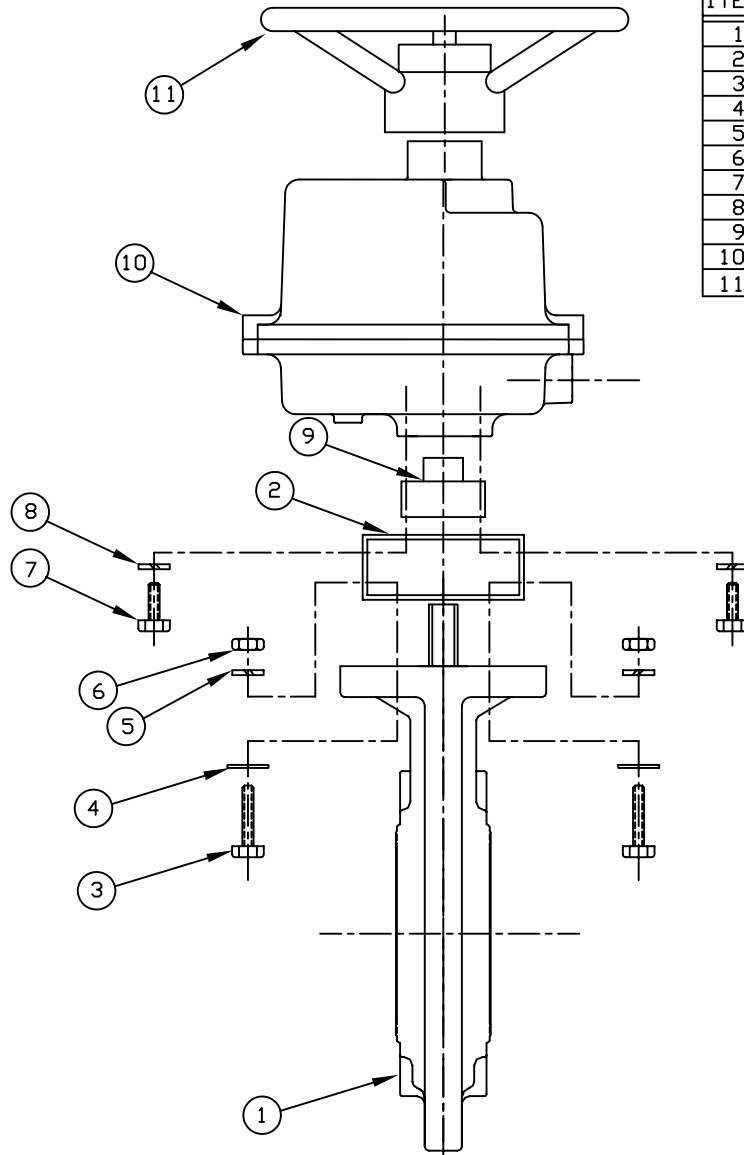
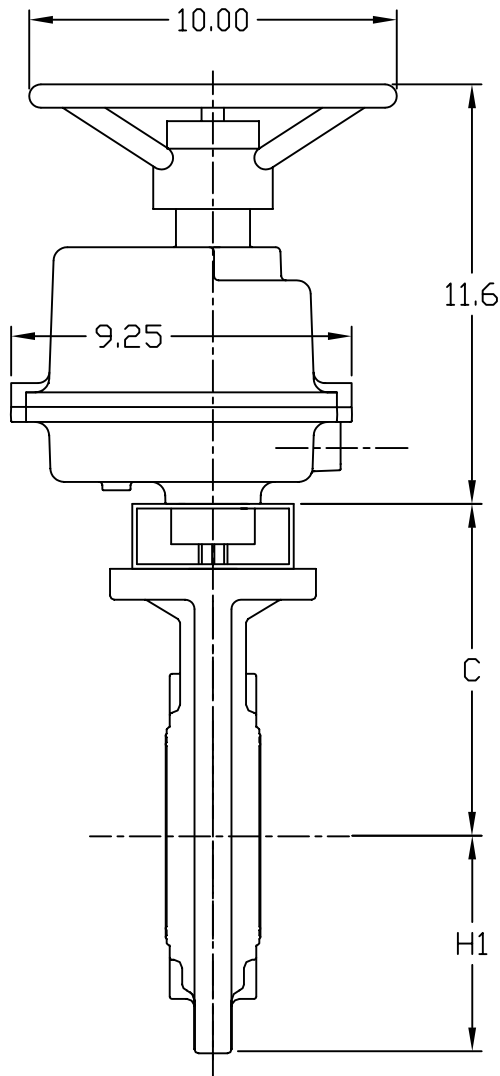

ITEM	DESCRIPTION	MATERIAL	QTY
1	BUTTERFLY VALVE		1
2	BRACKET MOUNTING	300 SS	1
3	SCREW	300 SS	4
4	WASHER FLAT	300 SS	4
5	WASHER LOCK	300 SS	4
6	NUT HEX	300 SS	4
7	SCREW	300 SS	4
8	WASHER LOCK	300 SS	4
9	SHAFT ADAPTER	300 SS	1
10	ACTUATOR	ALUM. EPOXY COATED	1
11	HANDWHEEL	ALUM. EPOXY COATED	1

FOR REFERENCE ONLY
ASAHI/AMERICA

THIS DRAWING AND ALL INFORMATION HEREON IS THE PROPERTY OF ASAHI/AMERICA. ANY COPYING, REPRODUCTION OR UNAUTHORIZED USE IS FORBIDDEN WITHOUT WRITTEN CONSENT.

	NAME	DATE
DR	JOHN GLASSFORD	6/10/05
APPD	DAVE HURLEY	6/10/05
PROD	LEO LESTER	6/10/05
PATH		
WO#/CO#		

ASAHI/AMERICA
ISO 9001 CERTIFIED
35 GREEN STREET, P.O. BOX 653, MALDEN, MA.



TYPE57 BF VALVE SERIES 92 2000 IN/LB ELECTRIC ACT		
SIZE	DWG. NO.	REV
A	0168BF57	A
SCALE	SHEET 1 OF 1	
NONE		

ACTUATOR SHOWN IN COUNTER-CLOCKWISE EXTREME OF TRAVEL, OR 'OPEN' POSITION

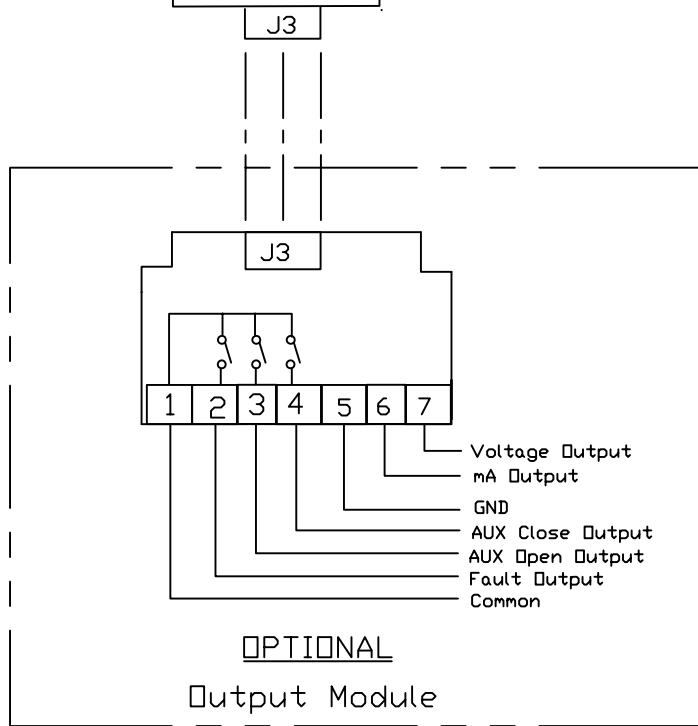
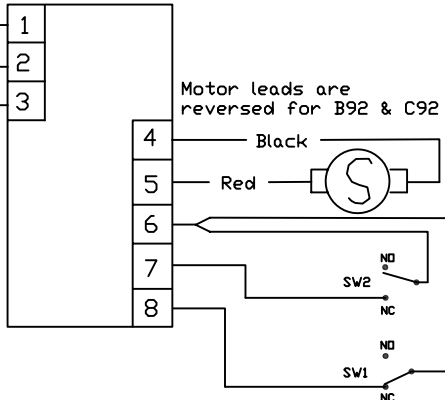
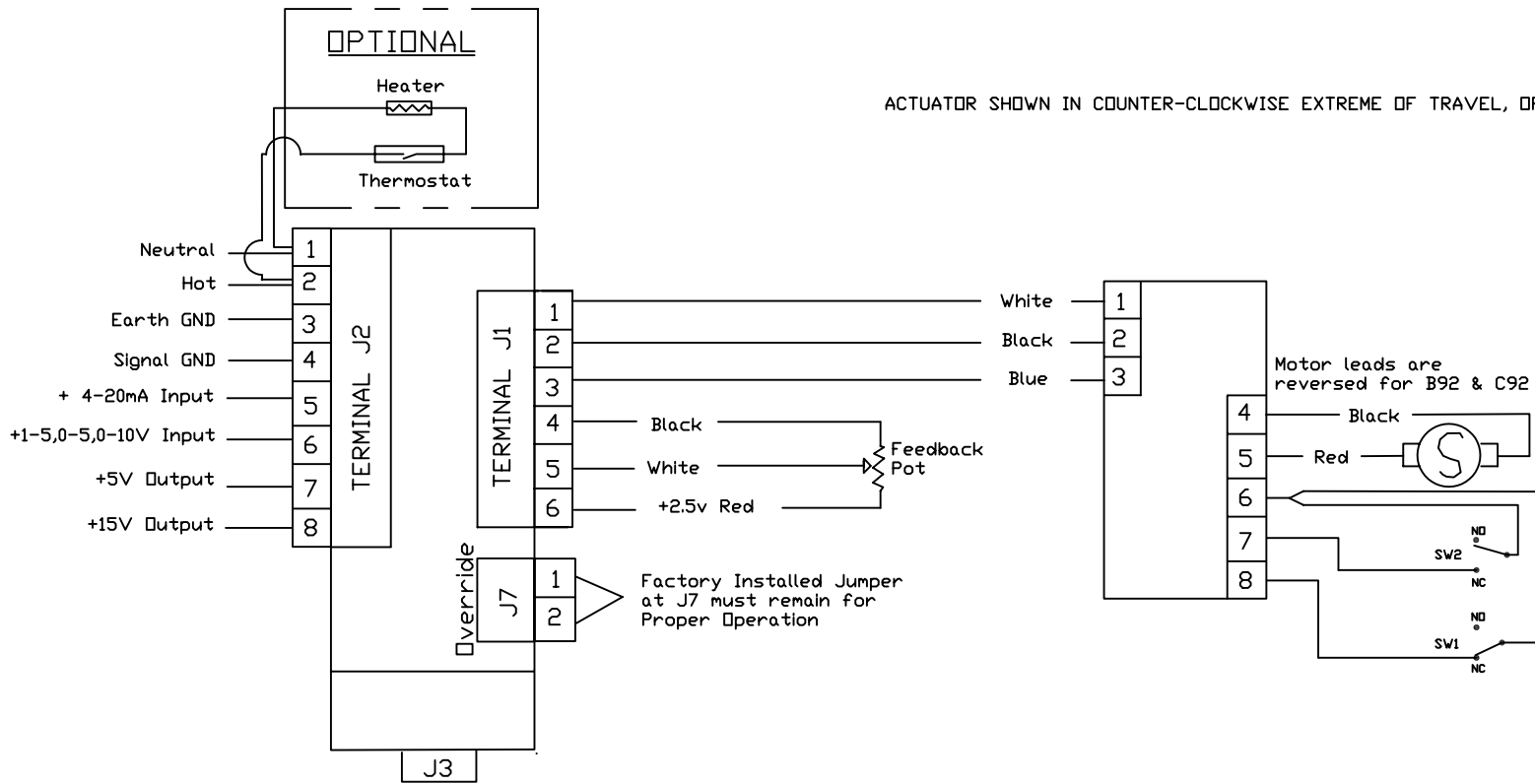

THIS DRAWING AND ALL INFORMATION HEREON IS THE PROPERTY OF ASAHI/AMERICA. ANY COPYING, REPRODUCTION OR UNAUTHORIZED USE IS FORBIDDEN WITHOUT WRITTEN CONSENT.

	NAME	DATE
DR	J. GLASSFORD	10/18/05
APPD	K. BLYSTONE	10/18/05
PROD		
WO#/SO#		
FILE		

ASAHI/AMERICA
 ISO 9001 CERTIFIED
 35 GREEN STREET, P.O. BOX 653, MALDEN, MA.



SERIES 92/94 24VAC
 W/DHC-100 POSITIONER

SIZE A	DWG. NO. M00EL382	REV A
SCALE NTS	SHEET 1 OF 1	

ACTUATOR SHOWN IN COUNTER-CLOCKWISE EXTREME OF TRAVEL, OR 'OPEN' POSITION

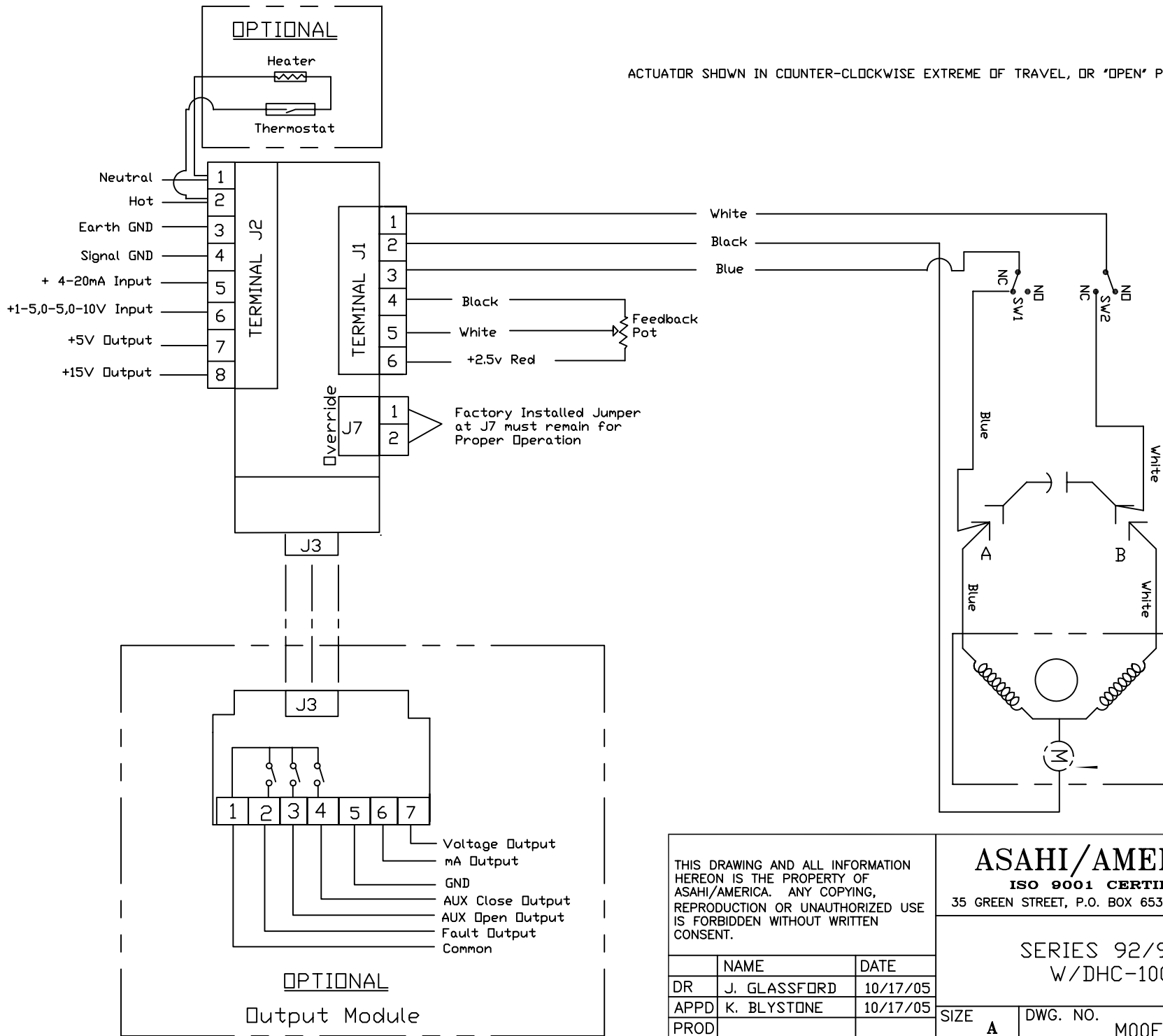

THIS DRAWING AND ALL INFORMATION HEREON IS THE PROPERTY OF ASAHI/AMERICA. ANY COPYING, REPRODUCTION OR UNAUTHORIZED USE IS FORBIDDEN WITHOUT WRITTEN CONSENT.

	NAME	DATE
DR	J. GLASSFORD	10/17/05
APPD	K. BLYSTONE	10/17/05
PROD		
WO#/SO#		
FILE		

ASAHI/AMERICA
 ISO 9001 CERTIFIED
 35 GREEN STREET, P.O. BOX 653, MALDEN, MA.



SERIES 92/94 115/230 VAC
 W/DHC-100 POSITIONER

SIZE	A	DWG. NO.	M00EL381	REV	A
SCALE	NTS		SHEET 1 OF 1		

SERIES 92

PARTS LIST & MATERIALS OF CONSTRUCTION

FOR REFERENCE ONLY
ASAHI/AMERICA

S92= 400 IN*LBS
A92= 700 IN*LBS
B92= 1100 IN*LBS
C92=2000 IN*LBS

ITEM NO	PART NO	QUANTITY				DESCRIPTION
		S92	A92	B92	C92	
1	7401920	1	1	1	1	BASE
2	7401440	1	1	1	1	WIRING HARNESS - 4 PCS
3	7401060	1	1	1	1	BASE PLATE
4	7401940	1	1	1	1	COVER
5	7401925	1	1	1	1	WIRING DIAGRAM LABEL
6	7401900	1	1	1	1	SHAFT MAIN
6A	7401905	-	-	-	-	SHAFT MAIN
7	7401360	2	2	2	2	PIN
8	7401280	-	-	-	-	SHAFT STUB
9	7402003	-	-	-	-	SPUR GEAR 1A
10	7402002	-	-	-	-	SPUR GEAR 1A
11	7401400	1	1	1	1	GEAR PINION
12	7401540	1	1	1	1	BEARING PINION
13	7402006	-	-	-	-	BEARING FL - SPUR GEAR
14	7401380	1	1	1	1	GEAR MAIN
15	7401200	1	1	1	1	SHAFT INNER
15A	7401210	-	-	-	-	SHAFT INNER
16	7401180	1	1	1	1	SHAFT RETAINER
17	7401300	1	1	1	1	KNOB LOWER
18	7401320	1	1	1	1	KNOB UPPER
18A	7401995	-	-	-	-	HANDWHEEL
19	7401260	1	1	1	1	COLLAR
20	7401120	1	1	1	1	BEARING UPPER COVER
21	7401080	1	1	1	1	BASE PLATE BEARING
22	7401020	1	1	1	1	BASE BEARING
23	7401480	2	2	2	2	CAM
24A	7401420	2	2	2	2	TERMINAL BLOCK 1-B
24B	7401425	2	2	2	2	TERMINAL BLOCK 9-16
25	7401460	2	2	2	2	SWITCH ACTUATOR
26	7401560	1	1	1	1	O-RING BASE/COVER
27	7401948	1	1	1	1	CAPACITOR 42 MFD
27A	7402004	-	-	-	-	CAPACITOR 6.7 MFD
28	7403008	-	-	-	-	CAPACITOR 7.6 MFD
29	7401520	1	1	1	1	CLAMP CAPACITOR
30	7401340	1	1	1	1	MOTOR
31	7401250	1	1	1	1	SHELL
32	7401220	1	1	1	1	SPRING
32A	7401230	-	-	-	-	SPRING
33	7401620	2	2	2	2	SCREW ROUND HD. 4-40 x 100 LG
34	7401240	1	1	1	1	WASHER, FLAT #10 6.450 x .06 THK
35	7401680	3	3	3	3	SCREW FLAT HD. 8-32 x .25 LG. SS.
36	7401640	8	8	8	8	SCREW HEX HD. 5/16-18 x 1.00 LG. SS.
37	7401521	1	1	1	1	SCREW SELF TAP (GREEN) #10 x .50 LG.
38	7401880	1	1	3	5	KEY WOODRUF 3/32
39	7401700	1	1	1	1	SCREW SLOT SET 8-32 x .50 LG. SS.
40	7401740	4	4	4	4	SCREW SET 8-32 x .12 LG.
41	7401600	4	4	4	4	BASE NAMEPLATE
42	7401660	5	5	5	5	SCREW SELF TAP SLOT/HEX #10 x .50 LG.
43	7401720	4	4	4	4	SCREW SLOT/HEX 10-32 x 1.62 LG.
44	7401040	1	1	1	1	SEAL BASE
45	7401140	1	1	1	1	SEAL COVER
46	7401580	1	1	1	1	O-RING SHAFT
47	7401950	1	1	1	1	DIVERIDE LABEL
48	7401960	1	1	1	1	COVER NAMEPLATE
49	7401970	1	1	1	1	BASE NAMEPLATE
50	7401430	1	1	1	1	CAPACITOR HARNESS- 2 PCS
51	7401485	-	-	-	-	HANDWHEEL CAM
52	8100179	-	-	-	-	CAM SCREW SET 1/4-20 x .750 LG.

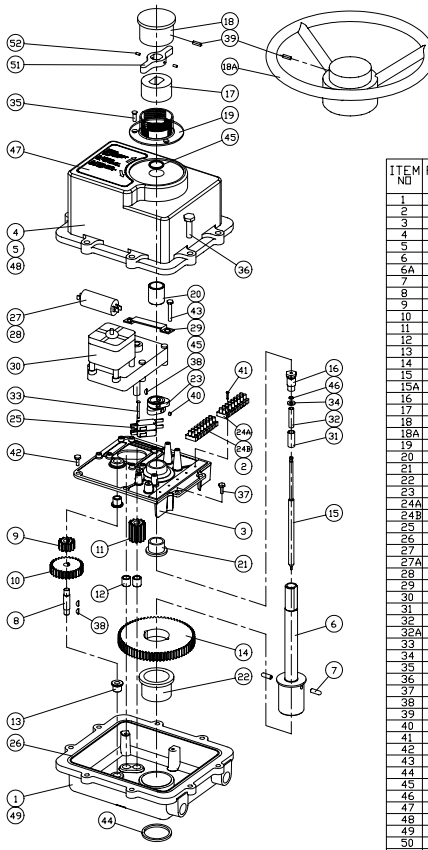

THIS DRAWING AND ALL INFORMATION HEREON IS THE PROPERTY OF ASAHI/AMERICA. ANY COPYING, REPRODUCTION OR UNAUTHORIZED USE IS FORBIDDEN WITHOUT WRITTEN CONSENT.

ASAHI/AMERICA

ISO 9001 CERTIFIED

35 GREEN STREET, P.O. BOX 653, MALDEN, MA.



SERIES 92 EXPLODED VIEW

NAME	DATE
DR A.SELEZNEV	2/17/98
CHK DAVE HURLEY	2/17/98
APPD LEO LESTER	2/17/98
PATH \ACAD11\S92	
DO NOT SCALE DRAWING	

SIZE	DWG. NO.	REV
A	289S92	3
SCALE	NTS	SHEET 1 OF 1