

# TYPE-C GATE VALVE WITH SERIES 19 MULTITURN **SMART** ON/OFF ELECTRIC ACTUATOR



## Standard Features (Sizes 1-1/2" - 4")

- **Compact:** Perfect for OEM and skid manufacturers
- **OLED Screen:** Displays valve position, alarms (such as an over torque condition)
- **Push Buttons:** Used to calibrate/adjust end positions, local controls
- **Multi-voltage:** 95 VAC to 265 VAC or 24VAC/VDC
- **Motor:** Reversing, brushless DC motor
- **Gear Train:** Permanently lubricated steel gears
- **Corrosion Resistant Enclosure:** NEMA 4X PC/PET enclosure with stainless steel trim
- **ISO mounting configuration**
- **Electrical Connection:** NEMA 4X cable gland with two-meter cable
- **Visual Position Indication:** Flat disc position indicator
- **LED Position Indication:** RED closed, GREEN open, BLUE fault
- **Manual Override:** Manually cycle valve via electroless nickel-plated hex key
- **Auxiliary Contacts:** Open and closed dry contacts rated 0.1 Amp @ 250 VAC, 0.5 Amp @ 30 VDC
- **Alarm Contacts:** Dry contacts rated 0.1 Amp @ 250 VAC, 0.5 Amp @ 30 VDC for alarm status (over torque, as an example)
- **QR Code:** Links to user manual; includes wiring schematic
- **Space Heater:** Internally wired to limit condensation
- **CE Compliant:** All actuators are CE labeled and compliant
- **70% Duty Cycle:** Extended duty cycle is ideal for high cycling applications
- **Simple Wiring:** Wiring technique is the same for all voltage units
- **Local Controls:** Used with OLED and push buttons, a user can locally open or close units via password

## Specifications

<b>Motor Type:</b>	Reversing, brushless DC
<b>Sizes:</b>	S50 for 1-1/2" - 4" gate valves
<b>Torque:</b>	442 in-lbs
<b>Voltage:</b>	95 VAC to 265 VAC multi-voltage
<b>Amp Draw:</b>	0.24 Amp for S50
<b>Max Ambient Temp:</b>	150° F

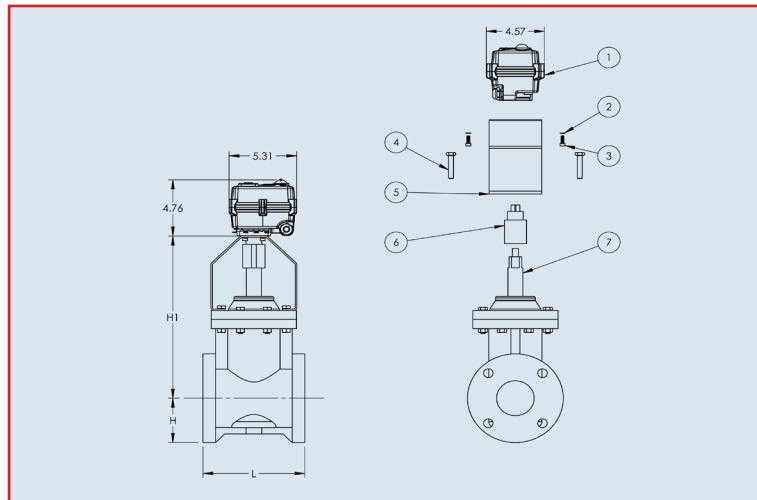

## Dimensions (inch)

Size	1-1/2"	2"	3"	4"
H	2.50	3.00	3.75	4.5
H1	9.00	10.46	14.06	15.74
L	6.50	7.01	7.99	9.02
MODEL	S50MT	S50MT	S50MT	S50MT

## Engineering Data

Size	Model	Torque (in/ lbs)	95-265 VAC		Cycle time (seconds)*	Weight (lbs)
			Amp Draw	Duty Cycle		
1-1/2"	S50MTHM2W	442	0.24	70%	92	11.2
2"	S50MTHM2W	442	0.24	70%	92	13.8
3"	S50MTHM2W	442	0.24	70%	156	20.2
4"	S50MTHM2W	442	0.24	70%	156	29.8

Size	Model	Torque (in/ lbs)	24 VAC/VDC		Cycle time (seconds)*	Weight (lbs)
			Amp Draw	Duty Cycle		
1-1/2"	S50MTHM2W	442	1.2	70%	84	11.2
2"	S50MTHM2W	442	1.2	70%	84	13.8
3"	S50MTHM2W	442	1.2	70%	100	20.2
4"	S50MTHM2W	442	1.2	70%	156	29.8

Amp draw is considered locked rotor

\*Cycle times are approximate

Duty cycle shown for ambient temp (73° F)

# TYPE-C GATE VALVE WITH SERIES 19 MULTITURN **SMART** ON/OFF ELECTRIC ACTUATOR

## Wiring Diagram

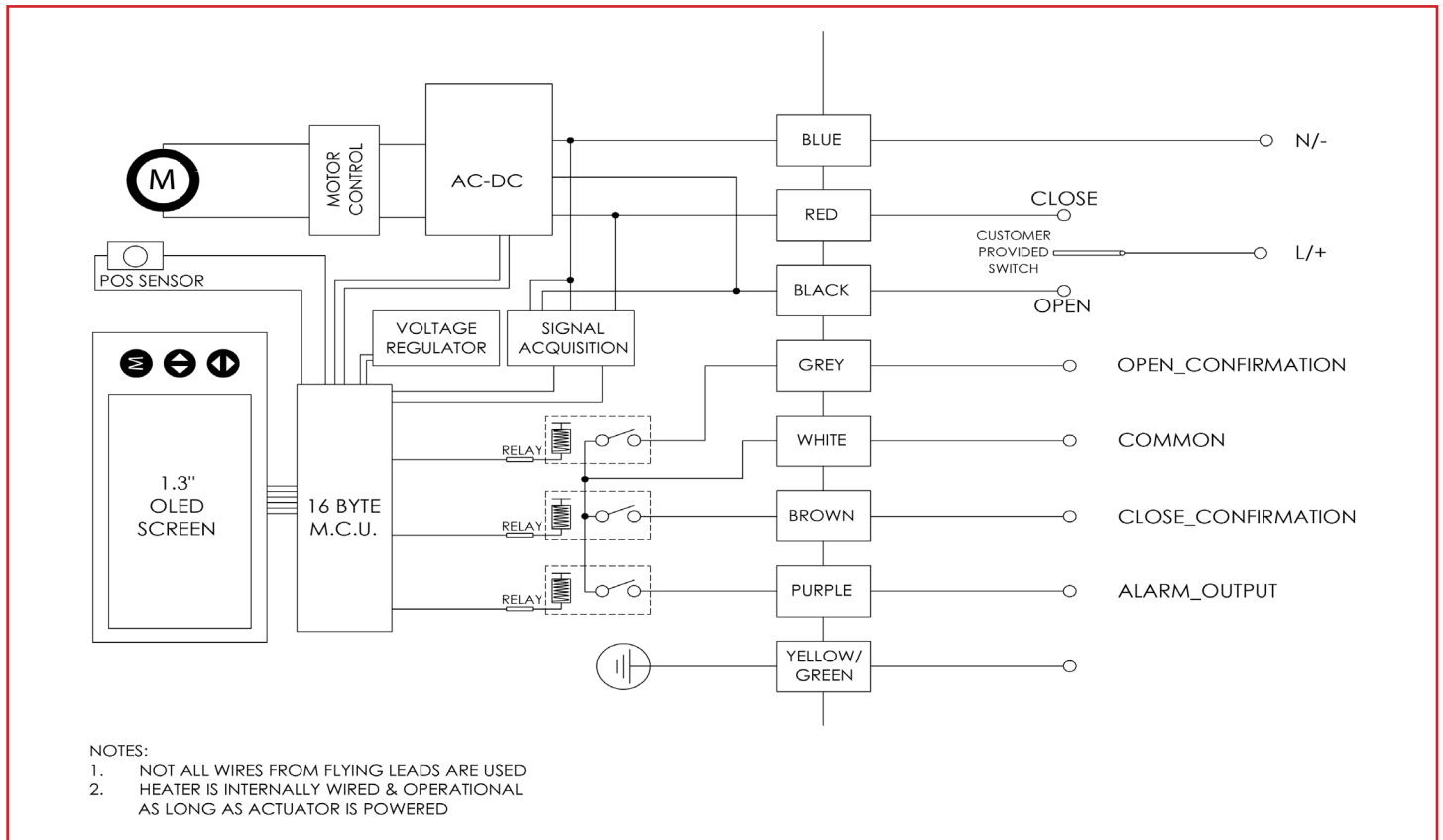

## Sample Specifications

All Series 19 SAV smart on/off multiturn electric actuators shall have a brushless DC motor that accepts multiple voltages, permanently lubricated steel gears, NEMA 4X PC/PET enclosure with stainless steel trim, visual position indication, ISO 5211 valve mounting platform, manual override, and be CE compliant. Standard features shall include a heater, one set of dry contacts for PLC confirmation, one set of dry contacts for alarm reporting, LED indicator for position and alarm conditions, an OLED screen with push buttons, local controls, and a QR code that links to its user manual and wiring schematic.

