

DETAIL OF TAG HOLE

VALVE SIZE	Ø	# TAG HOLE
1-1/2" - 12"	8mm	2
14"	12mm	2

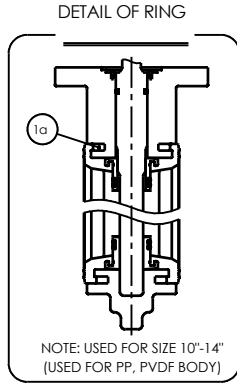

NOTE: USED FOR SIZE 10"-14"
(USED FOR PP, PVDF BODY)

DIMENSIONS TABLE

NOMINAL SIZE	ANSI CLASS 150																NUMBER OF HANDLE WHEEL ROTATION	GEAR BOX TYPE	
	d	C	n	h	D	D1	D2	D3	L	H	H1	H2	H3	I	A1	A2			
1 1/2"	40mm	1.77	3.88	4	0.62	5.91	2.83	4.80	6.30	1.54	5.12	2.95	3.74	3.54	8.27	6.57	2.52	9.5	241
2	50	2.20	4.75	4	0.75	6.50	3.23	4.80	6.30	1.65	5.51	3.25	4.13	3.54	8.66	6.57	2.52		
2 1/2	65	2.72	5.50	4	0.75	7.28	3.78	4.80	6.30	1.81	5.91	3.64	4.53	3.54	9.06	6.57	2.52		
3	80	3.03	6.00	4	0.75	8.31	4.17	4.80	6.30	1.81	6.50	4.15	5.12	3.54	9.65	6.57	2.52		
4	100	4.02	7.50	8	0.75	9.37	5.31	4.80	6.30	2.20	7.09	4.69	5.71	3.54	10.24	6.57	2.52		
5	125	5.08	8.50	8	0.88	10.39	6.69	4.80	6.30	2.60	7.68	5.20	6.30	3.54	10.83	6.57	2.52		
6	150	5.91	9.50	8	0.88	11.22	7.52	4.80	6.30	2.80	8.27	5.61	6.89	3.54	11.42	6.57	2.52		
8	200	7.68	11.75	8	0.88	13.39	9.53	4.80	6.30	3.43	9.49	6.69	8.11	3.54	12.64	6.57	2.52		
10	250	9.84	14.25	12	1.00	16.57	11.89	4.80	6.30	4.33	10.87	8.31	9.49	3.62	14.02	6.57	2.52		
12	300	11.93	17.00	12	1.00	19.21	14.17	7.40	11.81	5.08	13.39	9.61	11.73	4.25	19.29	10.71	3.90		
14	350	13.82	18.75	12	1.12	21.22	15.47	7.40	11.81	5.08	14.45	10.63	12.80	4.25	20.35	10.71	3.90		

NOTE: THE SHAPE AND APPEARANCE OF ASSEMBLY DIFFER A LITTLE WITH NOMINAL SIZE COMPARED TO THE DRAWING

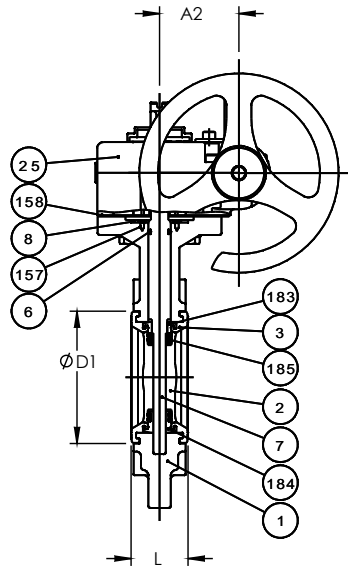
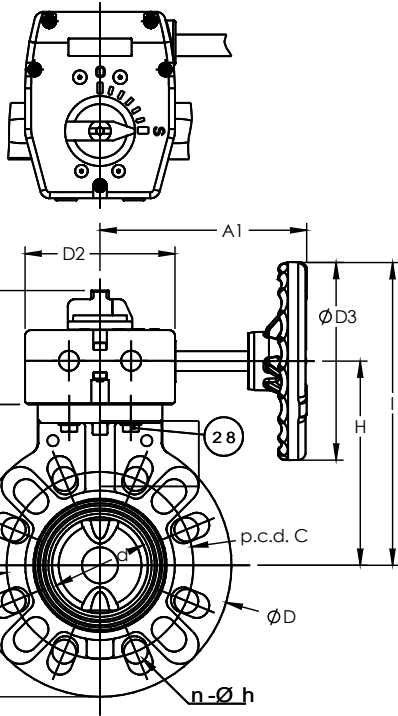

NO.	DESCRIPTION	NO. REQ'D	MATERIAL	REMARKS
1a	RING	2	S20C (Carbon Steel Trivalent White)	PP, PVDF BODY USED FOR SIZE 10-14
158	GASKET (L)	1	EPDM	
157	SCREW (F)	4	STAINLESS STEEL 304	
28	BOLT (C)	4	STAINLESS STEEL 304	
25	GEAR BOX	1	PLASTIC, ETC.	
8	STEM RETAINER (A)	1	PP	
7	STEM	1	<input type="checkbox"/> STAINLESS STEEL 403 <input type="checkbox"/> STAINLESS STEEL 316	
185	O-RING (I)	4	<input type="checkbox"/> EPDM <input type="checkbox"/> FKM <input type="checkbox"/> OTHERS	
6	O-RING (C)	1	<input type="checkbox"/> OTHERS	
3	SEAT	1	()	
184	SEAT BUSH (B)	1	BODY / DISC <input type="checkbox"/> PVC <input type="checkbox"/> PVC <input type="checkbox"/> CPVC <input type="checkbox"/> CPVC <input type="checkbox"/> PP <input type="checkbox"/> PP <input type="checkbox"/> PVDF <input type="checkbox"/> PVDF	
183	SEAT BUSH (A)	1		
2	DISC	1		
1	BODY	1		

UNLESS OTHERWISE SPECIFIED DIMENSIONS ARE IN INCHES MACHING TOLERANCES: 2 PL DECIMALS ±.01 3 PL DECIMALS ±.005 ANGULAR FRACTIONAL ± 1/2° FRACTIONAL ± 1/64 FABRICATION 1/2" - 8" ± 1/4 10" AND UP ± 1/2 TOLERANCES: ANGULAR ± 1.0°	THIS DRAWING AND ALL INFORMATION HEREIN IS THE PROPERTY OF ASAHI/AMERICA. ANY COPYING, REPRODUCTION OR UNAUTHORIZED USE IS FORBIDDEN WITHOUT WRITTEN CONSENT.	ASAHI/AMERICA ISO 9001 CERTIFIED 655 ANDOVER STREET, LAWRENCE, MA	
		NAME: J. Hughes DATE: 02/07/17 DR: J. Hughes REV:	BUTTERFLY VALVE TYPES7P GEAR TYPE 1-1/2" THRU 14" JDE PART # 0172BF57P
WELD TYPE: N/A MATERIAL: AS NOTED FINISH: 125µf	APPR: D. Hurley DATE: 12/04/19 PRODUCT: VALVE & ACT WO#/SO#	SIZE B SCALE N/A	DWG # 0172BF57P SHEET 1 OF 1 REVISION B